



CITY OF DIXON, ILLINOIS
Post Office Box 386
Dixon, Illinois 61021
Telephone: 815.288.1485

DIXON MUNICIPAL AIRPORT
CHARLES R. WALGREEN FIELD

OVERLAY TAXIWAYS A, A1, A2 AND C;
REMOVE AND REPLACE TAXIWAY C1

AIP PROJECT NO. 3-17-0036-B9
IDA PROJECT NO. C73-3549

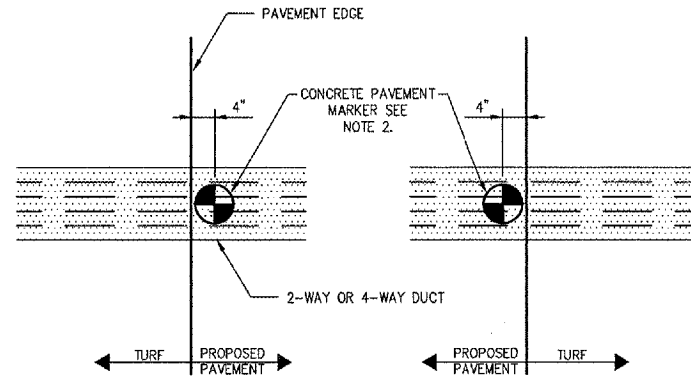

LOCATION PLAN

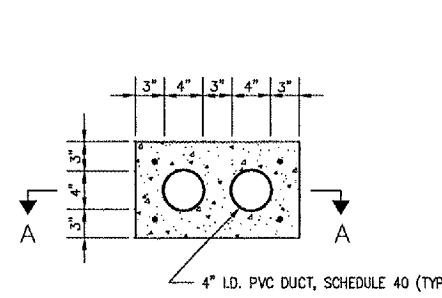

2-WAY

CONCRETE ENCASED DUCT CONFIGURATION

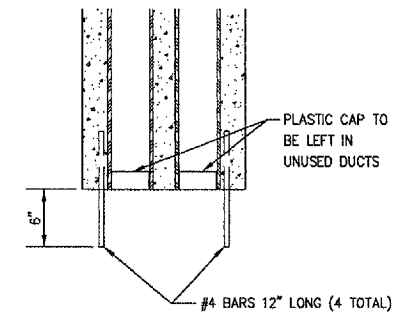

SECTION A-A

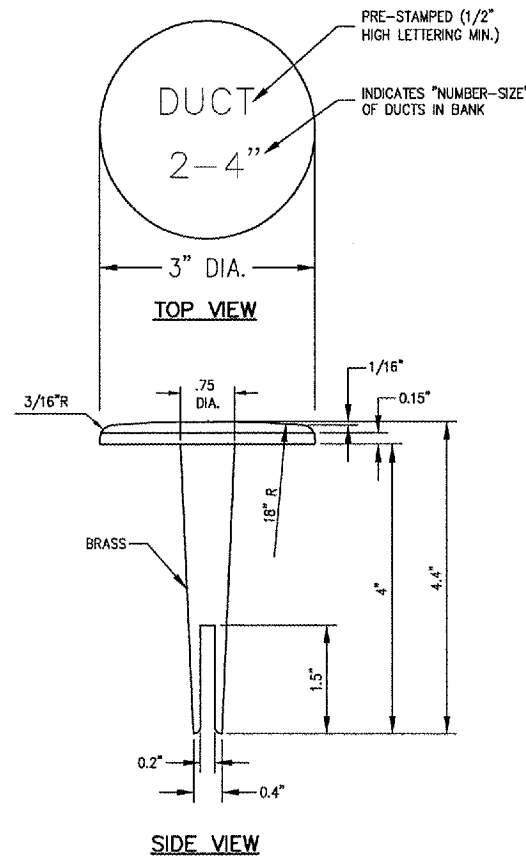

BITUMINOUS PAVEMENT MARKER

NOTES:

- 1. TOP OF MARKER SHALL BE FLUSH WITH FINISHED PAVEMENT SURFACE. MARKER MAY BE INSTALLED IN A DRILLED HOLE AND SECURED WITH EPOXY GLUE.
- 2. THE COSTS OF ALL TURF AND PAVEMENT DUCT MARKERS SHALL BE INCIDENTAL TO THE DUCT.
- 3. BITUMINOUS PAVEMENT DUCT MARKER TO BE PROVIDED AT EACH END OF DUCT AS SHOWN ON THE LOCATION PLAN.

No.	Drawing Issue Description	Date	By

Date
MARCH 3, 2006
Sheet Title

UNIT DUCT DETAILS

843-05B8009

Project Number	
KLK	01/05/04
Layout By	Date
TMM	01/09/04
Designed By	Date
RMH	03/05/04
Reviewed By	Date
KLK	
Drawn By	

I:\05-005\0084\DRAWINGS\DRMINGS\SHEET142-UNIT DUCT DETAILS.DWG MAR 10 2006 10:20AM NLK