

DETAIL TOP OF BEARING WALLS
SCALE: NONE

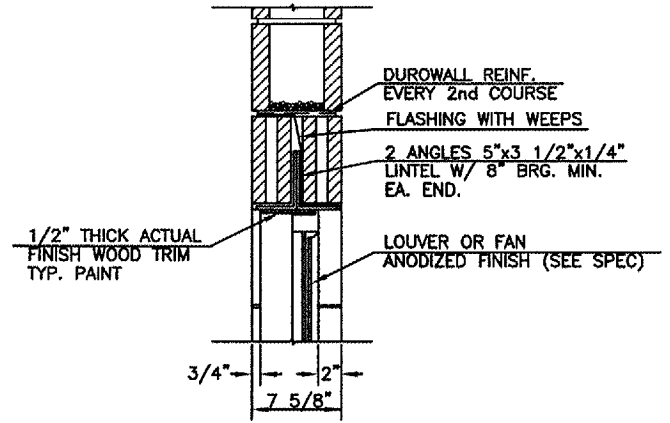

HEAD - EXT. OPENING
SCALE: NONE

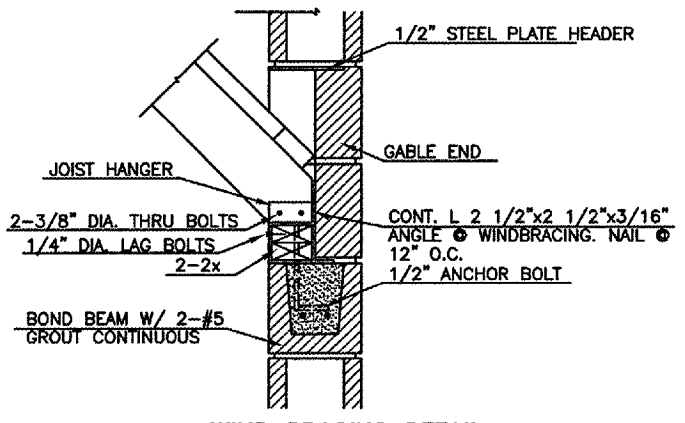

WIND BRACING DETAIL
SCALE: NONE

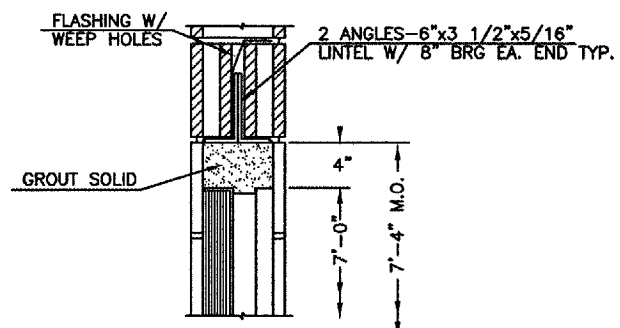

HEAD - EXT. DOOR
SCALE: NONE

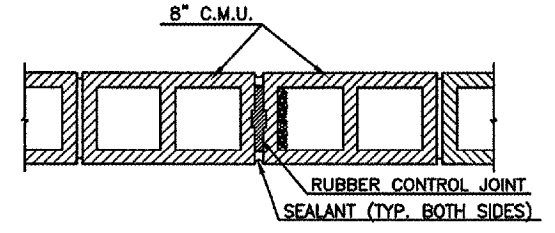

TYP. MASONRY CONTROL JOINT
SCALE: NONE

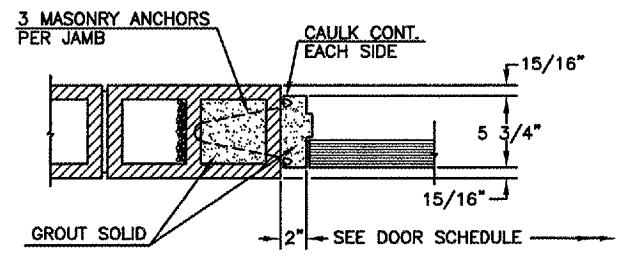

JAMB DETAIL
SCALE: NONE

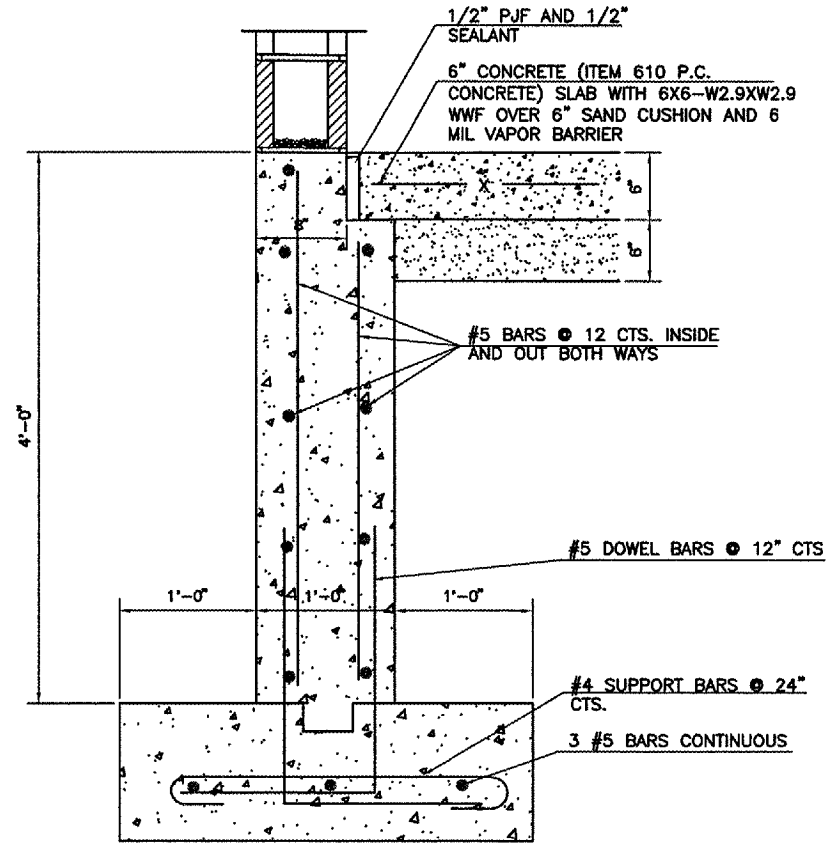

FOUNDATION WALL DETAIL
SCALE: NONE

GALESBURG MUNICIPAL AIRPORT GALESBURG, ILLINOIS	
ELECTRICAL VAULT BUILDING DETAILS	
HUTCHISON ENGINEERING, INC. JACKSONVILLE, ILLINOIS	
DRAWN BY: L.A.W.	ILL. PROJ. NO. C66-3433
DATE: MARCH, 2006	APP PROJ. NO. 3-17-0047-B8