

STATE OF ILLINOIS  
DEPARTMENT OF TRANSPORTATION

ROUTE NO.	SECTION	COUNTY	SHEET NO.	TOTAL SHEETS
383	29R-T	McHENRY	66	53
F.A.P. 383		FED. AID PROJECT		

CONTRACT NO. 62202

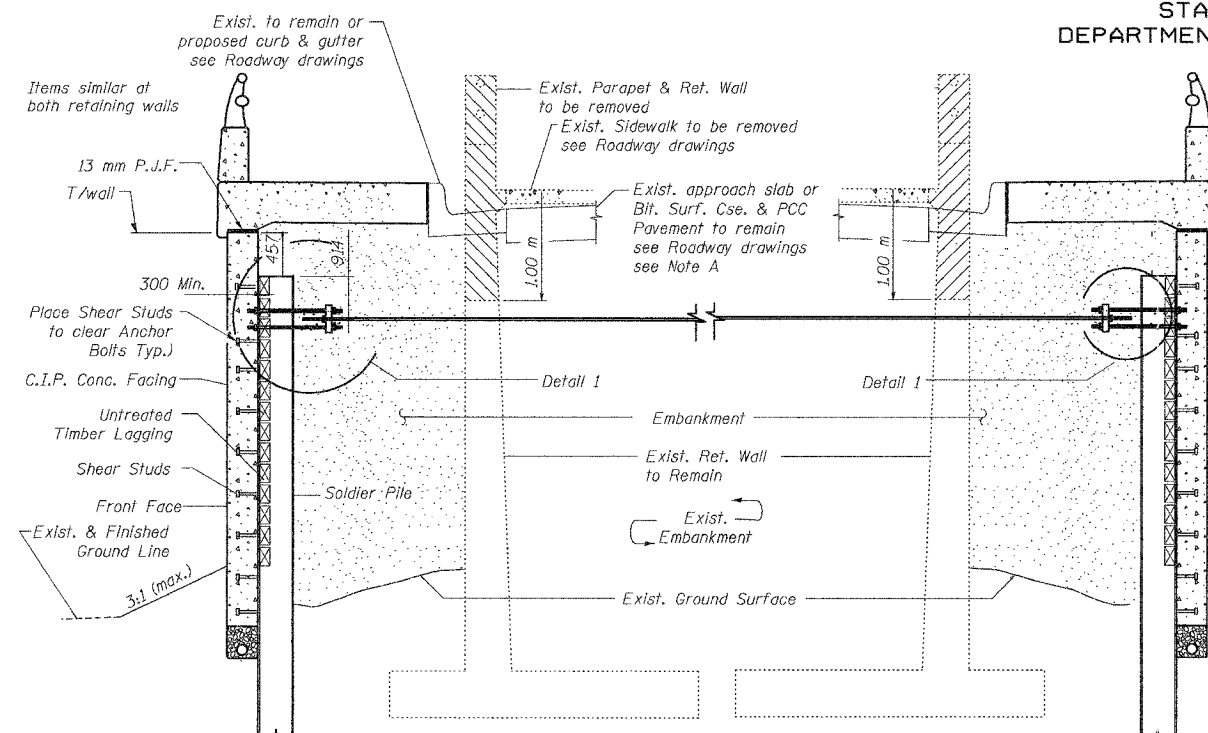

TYPICAL SECTION AT PILE TO PILE TIE ROD

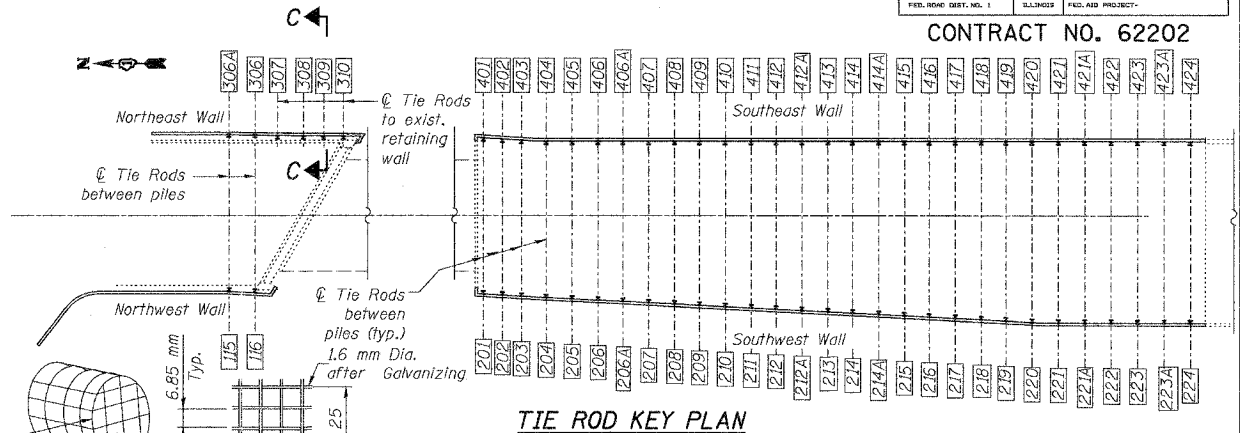

TIE ROD KEY PLAN

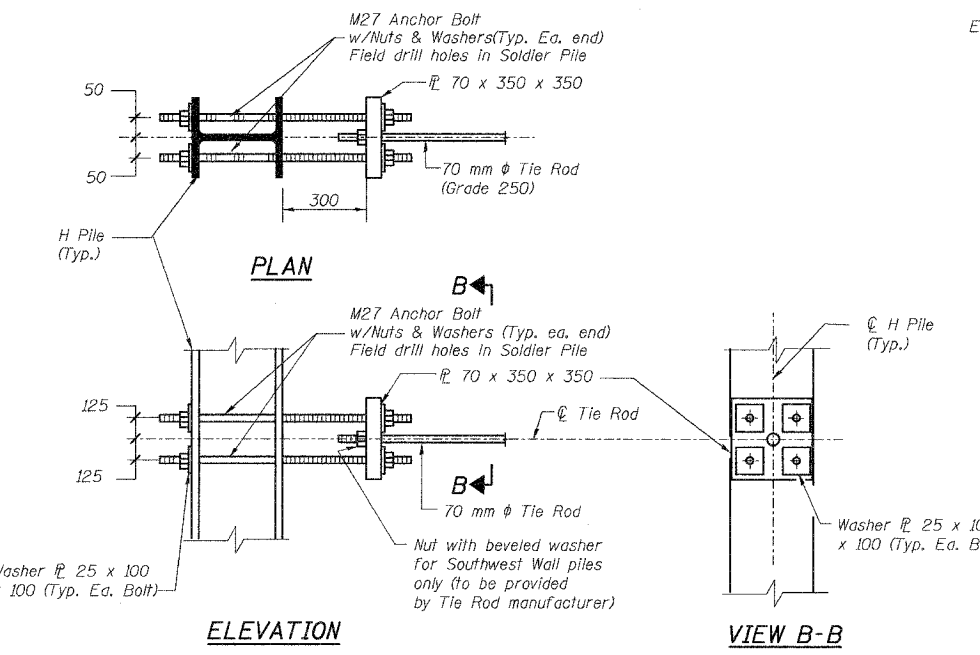

PLAN

ELEVATION

VIEW B-B

DETAIL 1

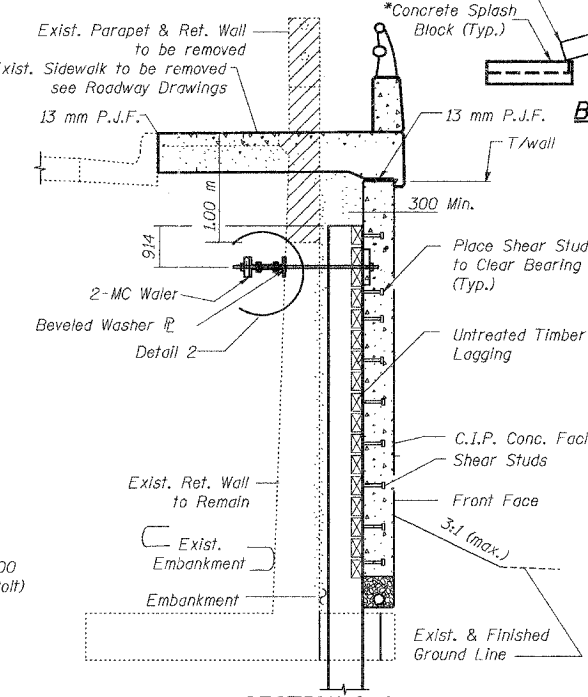

SECTION C-C  
(NEAR EAST CORNER OF NORTH ABUTMENT)

RODENT SHIELD  
DETAILS

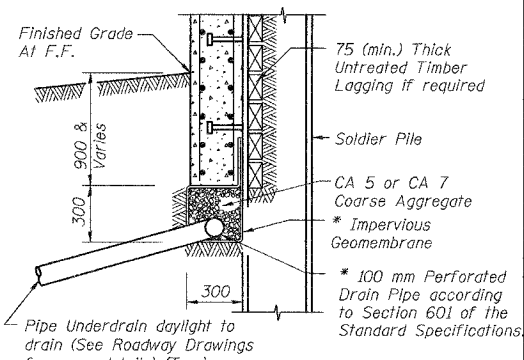
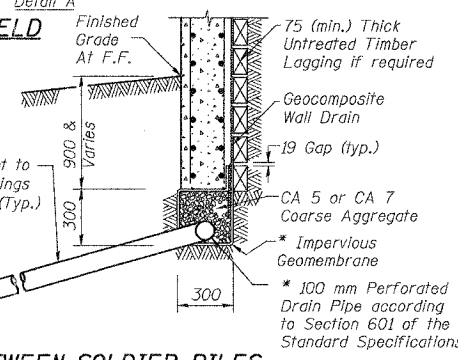

PIPE UNDERDRAIN DETAILS

AT SOLDIER PILES

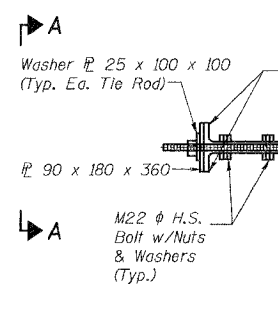

DETAIL 2

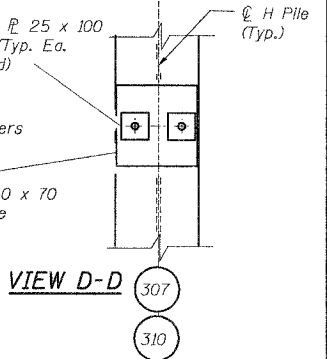

VIEW D-D

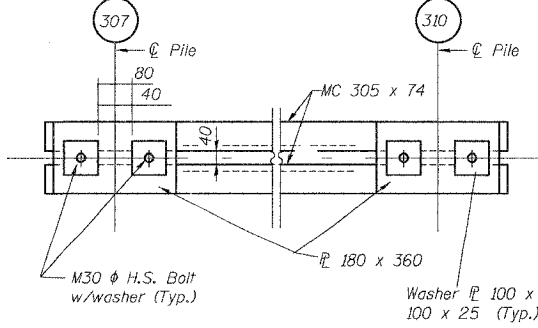

VIEW A-A

\*\*Width of Spacers to Equal Dia. of Tierods  
Sheet S1-14 of 37

DRAINAGE & TIEBACK DETAILS

U.S. 14 RETAINING WALLS  
AT MOKELER CREEK  
SECTION 29R-T  
McHENRY COUNTY  
STA. 0+647.90 TO STA. 0+982.78  
AT STRUCTURE NO. 056-0007

Date: February, 2005 Scale: None

DESIGNED	J.S./R.A.
CHECKED	H.T./N.S.
DRAWN	J.S.
CHECKED	H.T./M.R.

**Soodan**  
Structural Engineers & Construction Consultants  
220 North Lincoln Street, Suite 300  
Chicago, Illinois 60602  
Tel: 312/953-0003 Fax: 312/953-8006  
E-Mail: transport@soodan.com

BILL OF MATERIAL

ITEM	UNIT	QUANTITY
Furnishing and Erecting Structural Steel	Kg	169.8
Pipe Underdrains for Structures 100 mm	m	141