

F.A. RTE.	SECTION	COUNTY	TOTAL SHEETS	SHEET NO.
			1360	858
STA.	TO STA.			
FED. ROAD DIST. NO.	ILLINOIS FED. AID PROJECT			

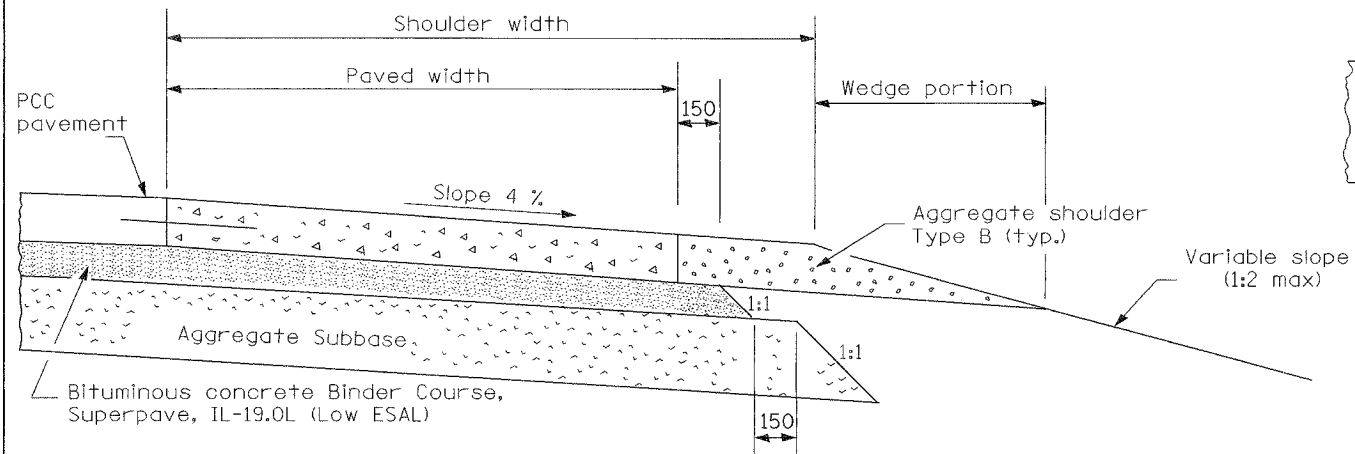

SHOULDER FOR TANGENT PAVEMENT

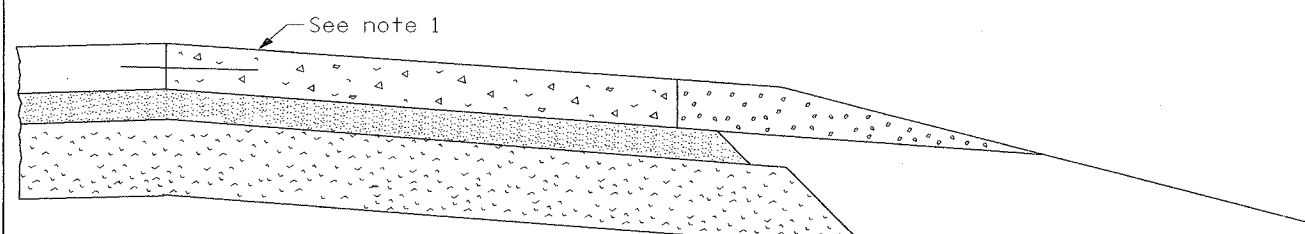

SHOULDER FOR SUPERELEVATED PAVEMENT (Outside of curve)

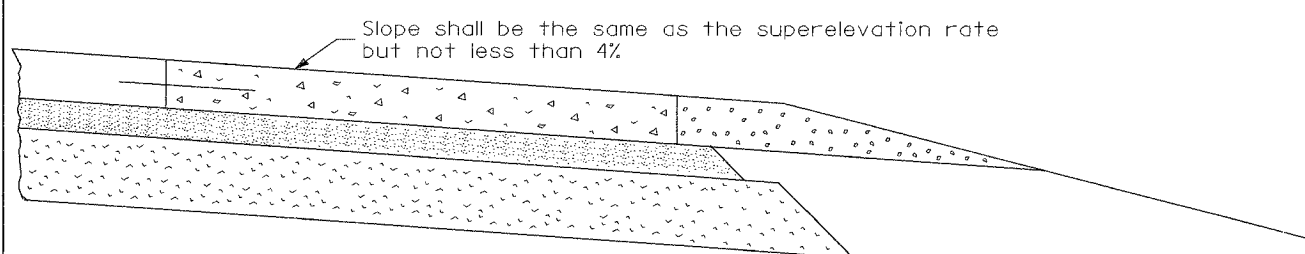

SHOULDER FOR SUPERELEVATED PAVEMENT (Inside of curve)

NOTES

Note 1: When the superlevation rate of the pavement is between 0% and 4%, the shoulder shall be sloped at 4%. When the superlevation rate of the pavement exceeds 4%, the shoulder shall be sloped so that the algebraic difference between pavement and shoulder slopes will not be greater than 8%.

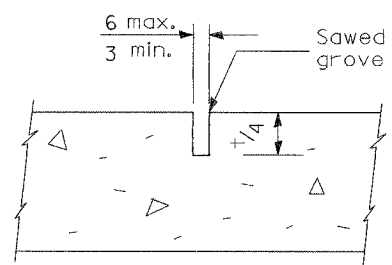

**DETAIL A
TRANSVERSE CONTRACTION JOINT**

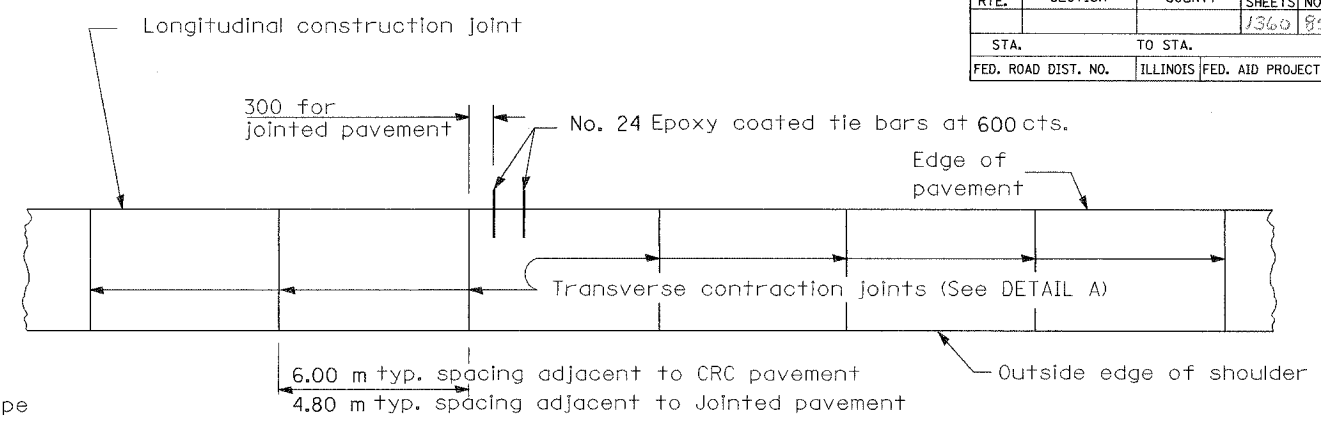

PLAN

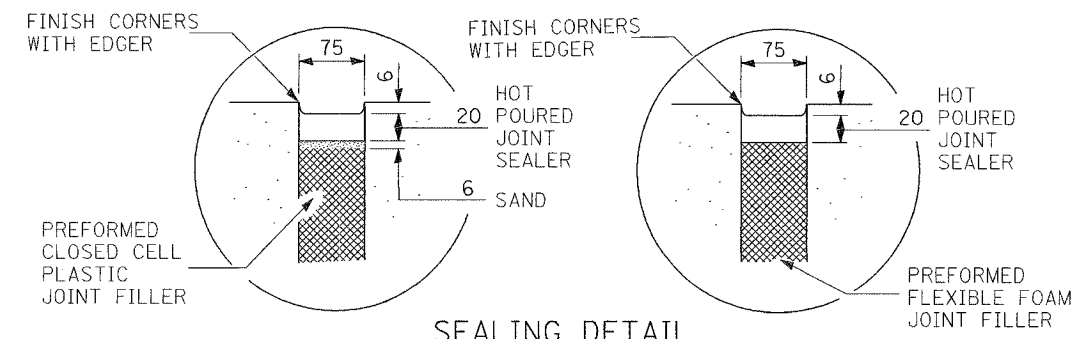

SEALING DETAIL

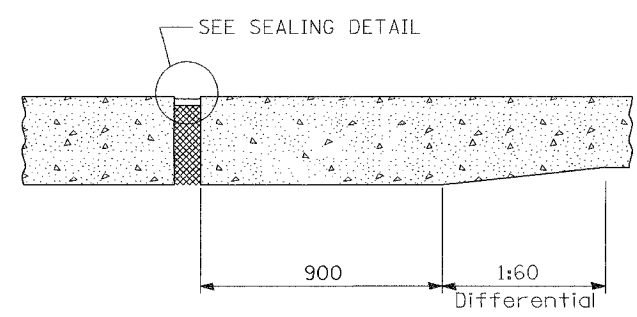

TRANSVERSE EXPANSION JOINT *

* TRANSITION FOR PAVEMENT WITH UNEQUAL THICKNESS AS APPLICABLE

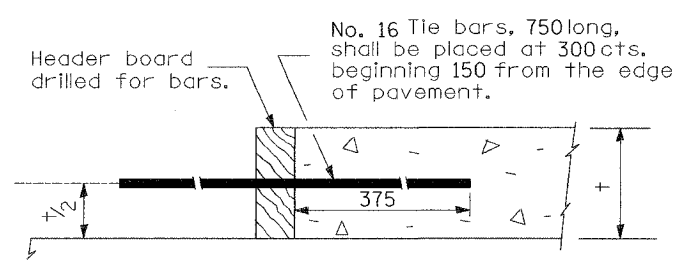

TRANSVERSE CONSTRUCTION JOINT

GENERAL NOTES

Except as noted or shown, the dimensions and notes specified for the shoulder of the tangent pavement are typical for the shoulders of superelevated pavement.

Transverse expansion joints thru the pavement, shall be extended thru the PCC shoulder.

Longitudinal construction joint(s) or longitudinal sawed joint(s) as shown on Standard 420001 shall be provided when the width of paved shoulder exceeds 4.5 m so that width between longitudinal joints does not exceed 4.5 m

Details of joints as shown on Standard 420001 except as otherwise shown herein

All dimensions are in millimeters unless otherwise shown.

REVISIONS	
NAME	DATE
INC. COMMENTS	3/7/02
REM. ENGL.	3/22/02
REV. TITLE	7/25/03
H.S. 2004	9/26/03

ILLINOIS DEPARTMENT OF TRANSPORTATION

I-74 PROJECT STANDARD 483001-I74

PCC SHOULDER FOR MAINLINE AND RAMPS

DRAWN BY
CHECKED BY

DATE 09/21/01