

STATE OF ILLINOIS  
DEPARTMENT OF TRANSPORTATION

PROPOSED HORIZONTAL CURVE DATA	
CURVE NO.	332
ALIGNMENT	RAMP C-3
DESIGN SPEED	80 km/h
P.I. STA.	10+356.775
R (m)	1293.773
T (m)	113.756
L (m)	226.928
E (m)	4.991
S.E.	2.70%
TRANSITION IN	10+238-10+245
TRANSITION OUT	10+466-10+478
P.C. STA.	10+243.019
P.T. STA.	10+469.948

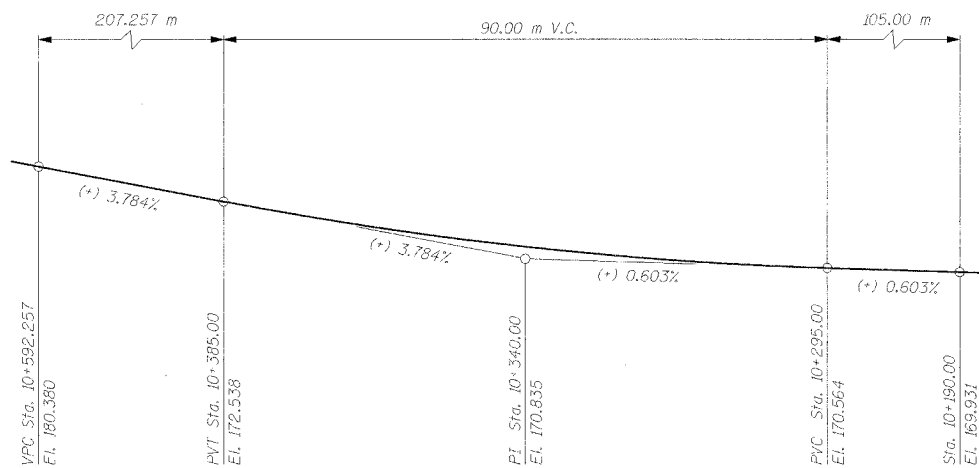

**B PROFILE GRADE OF RAMP C-3**

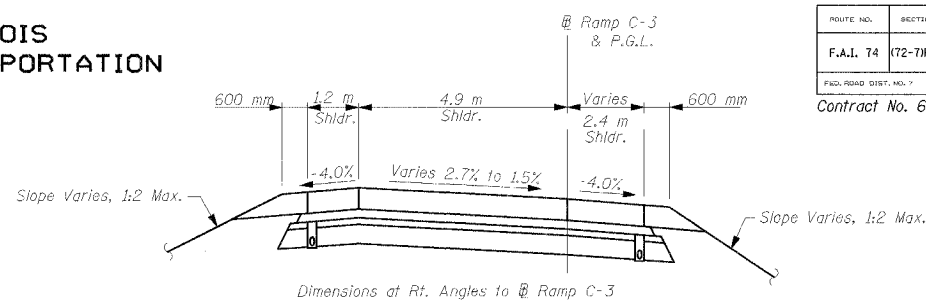

**RAMP C-3 SECTION**  
LOOKING NORTH

**TOTAL BILL OF MATERIAL**

ITEM	UNIT	TOTAL
Name Plates	Each	1
Reinforcement Bars, Epoxy Coated	kg	12,960
Concrete Superstructure	m <sup>3</sup>	27.0
Concrete Structures	m <sup>3</sup>	85.0
Structure Excavation	m <sup>3</sup>	1,357
French Drains	m <sup>3</sup>	16
Mechanically Stabilized Earth Retaining Wall	m <sup>2</sup>	435.2
Compressible Fill Material	m <sup>3</sup>	25
Weep Holes Cored	Each	39
Concrete Removal	m <sup>3</sup>	0.3
Reinforcement Bars	kg	110

**GENERAL NOTES**

- The Contractor shall coordinate and verify all drainage and roadway information with corresponding plans before beginning construction.
- Reinforcement bars shall conform to the requirements of AASHTO M31M or M322M Grade 400.
- All dimensions are in millimeters unless noted otherwise.
- Sawed contraction joints shall be placed in the anchorage slab to radially match the transverse joints in the pavement. See Std. 483001 & 420001-03 for contraction and expansion joint details in anchorage slab. Parapet joints shall be located at every other sawed anchorage slab joint. Parapet contraction joints shall be aluminum sheeted full height if cast-in-place, saw-cut full height if slip formed.
- Maximum applied bearing pressure = 148 kPa
- All construction joints shall be bonded.
- The anchorage slab and parapet shall not be placed until the MSE wall has been erected and allowed to settle for at least thirty calendar days, unless otherwise indicated on the plans.
- Plan dimensions and details relative to existing structure have been taken from existing structure plans and are subject to nominal construction variations. It shall be the Contractor's responsibility to verify such dimensions and details in the field and make necessary approved adjustments prior to construction or ordering of materials. Such variations shall not be cause for additional compensation for a change in the scope of the work, however, the Contractor will be paid for the quantity actually furnished at the unit price bid for the work.

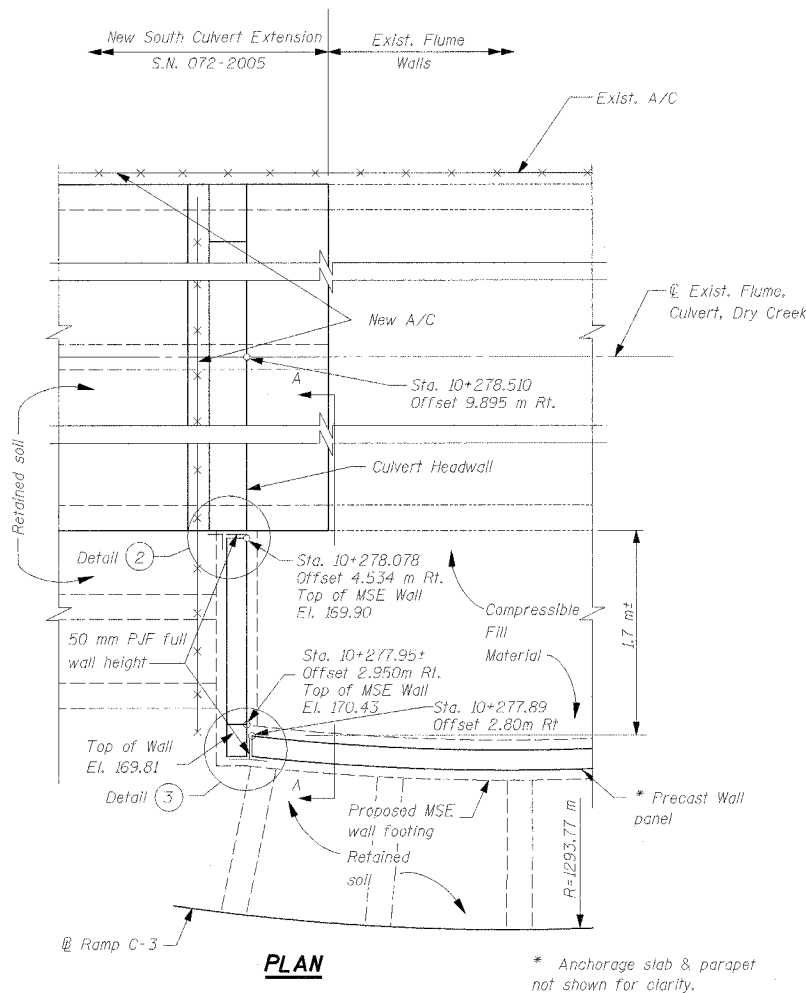

**PLAN**

**DETAIL 1**

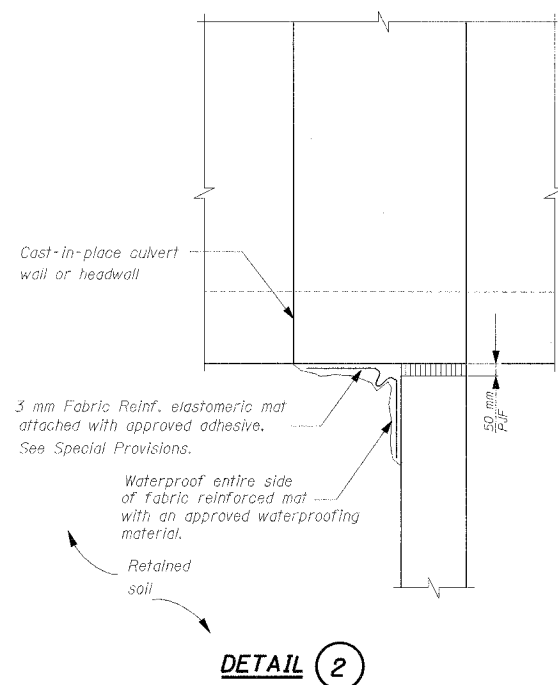

**DETAIL 2**

STA. 10+190.00-STA.10+277.94  
BUILT 20-- BY  
STATE OF ILLINOIS  
F.A.I. ROUTE 74 (72-7) R-3  
LOADING MS1B  
STR. NO. 072-8619

**NAME PLATE**  
See Std. 515001

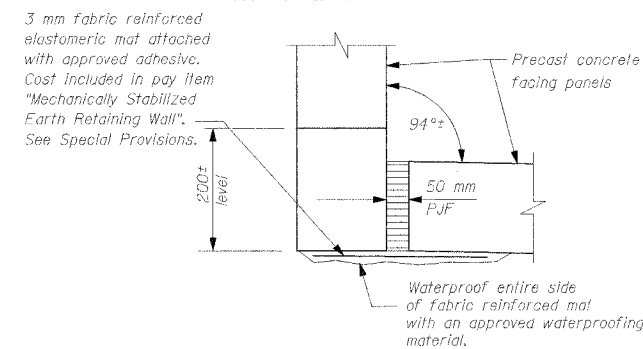

**DETAIL 3**

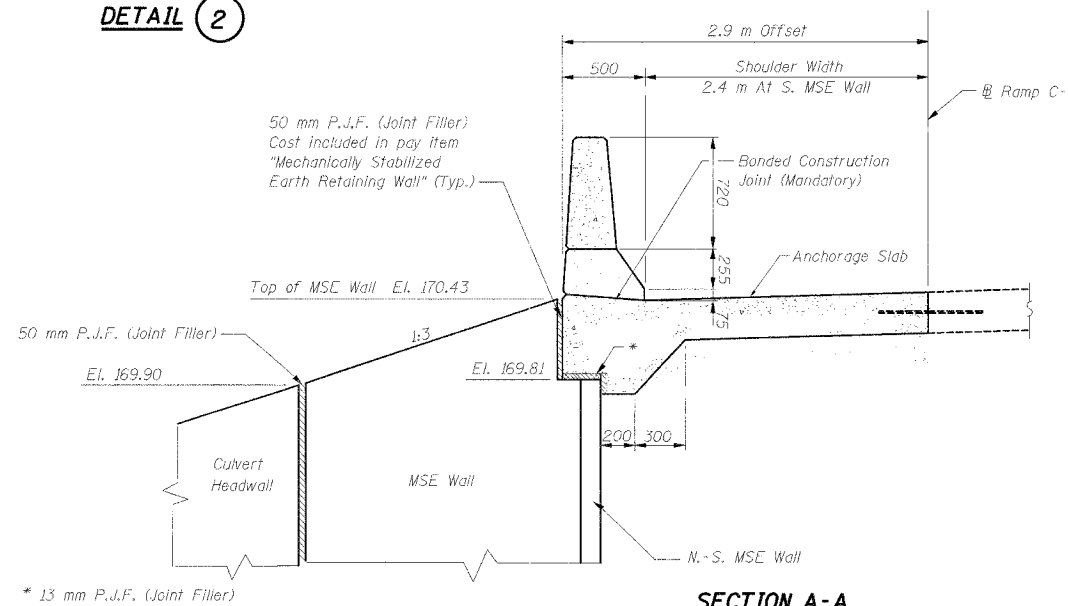

**SECTION A-A**

**SOUTH MSE WALL DETAILS**

**RAMP C-3 OVER DRY RUN CREEK**  
F.A.I. RTE 74(I-74) SECTION (72-7)R-3  
PEORIA COUNTY  
STA. 10+190.00 TO STA. 10+277.94 (RAMP C-3)  
STRUCTURE NUMBER 072-8619 - WALL 18C

DESIGNED	GEK
CHECKED	
DRAWN	GEK
CHECKED	

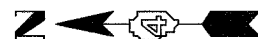

111 NE Jefferson Ave.  
Peoria, Illinois 61602  
Ph(309)676-8464  
FAX(309)676-5445