

STATE OF ILLINOIS
 DEPARTMENT OF TRANSPORTATION

DATE	BY	CHKD	APP'D
11/17/73	J.F.P.	J.F.P.	J.F.P.
11/17/73	J.F.P.	J.F.P.	J.F.P.
11/17/73	J.F.P.	J.F.P.	J.F.P.

12 SHEETS

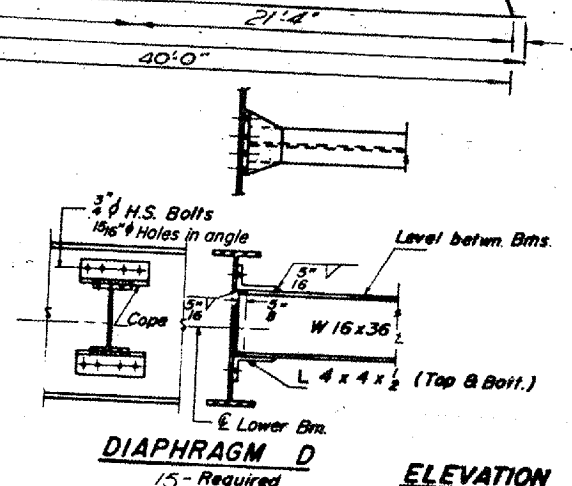
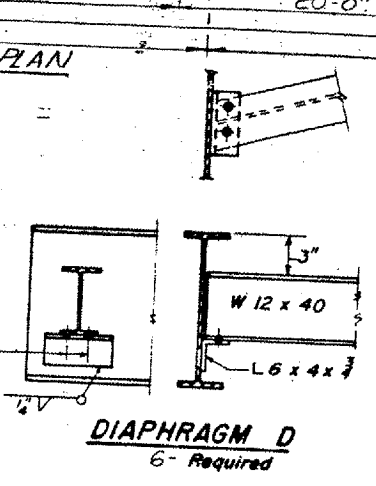
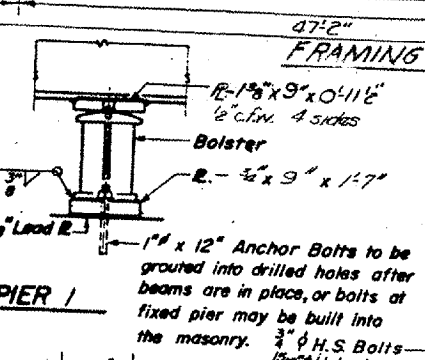
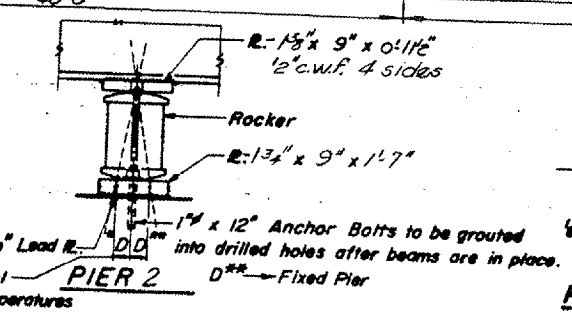
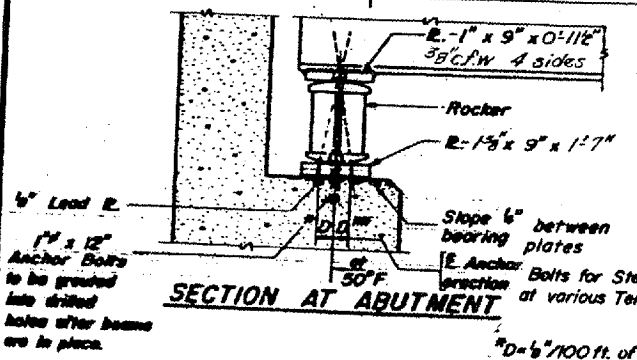
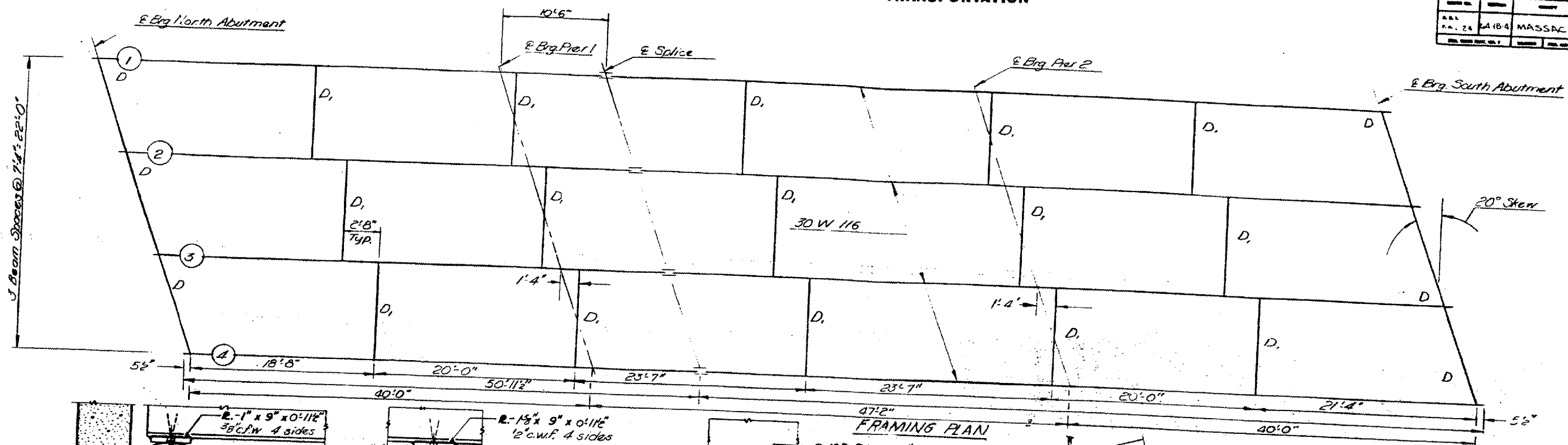

ELEVATION TOP OF WF

Location	Bm. 1	Bm. 2	Bm. 3	Bm. 4
E Brg N Abut.	358.12	358.00	357.96	357.80
E Brg Pier 1	358.58	358.43	358.37	358.28
E Splice	358.65	358.56	358.47	358.39
E Brg Pier 2	359.00	358.91	358.82	358.72
E Brg S Abut.	359.30	359.29	359.19	359.09

Note: Hardened washers shall be required over 1 1/16 inch holes in angles.

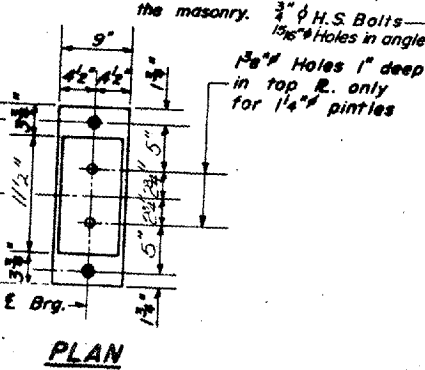
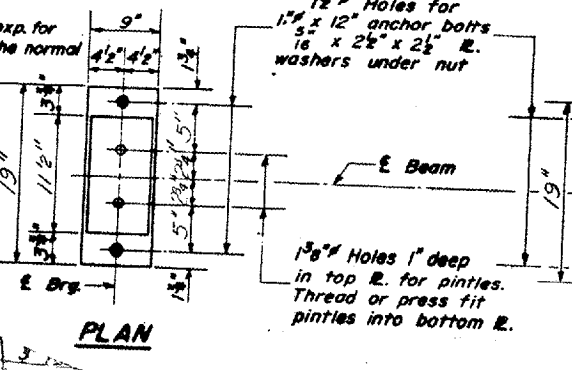
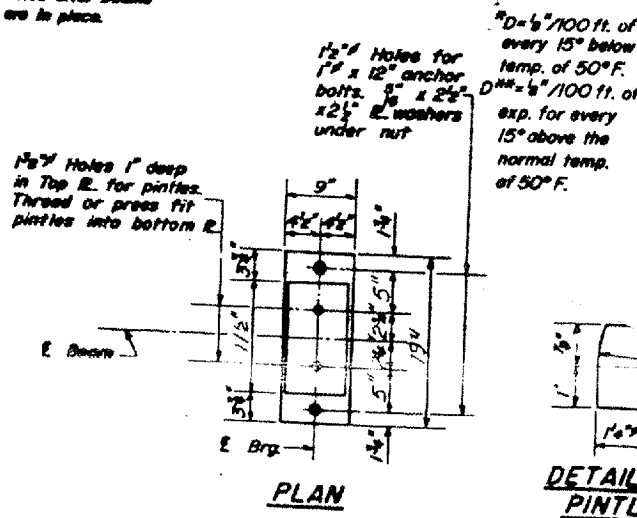

DETAIL OF PINTLE

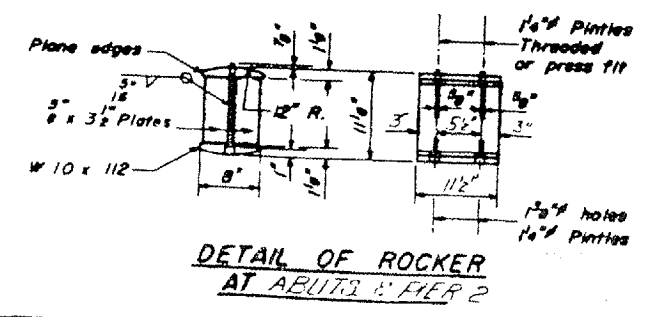

DETAIL OF BOLSTER AT PIER 1

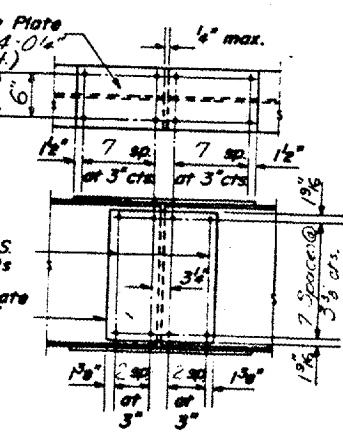
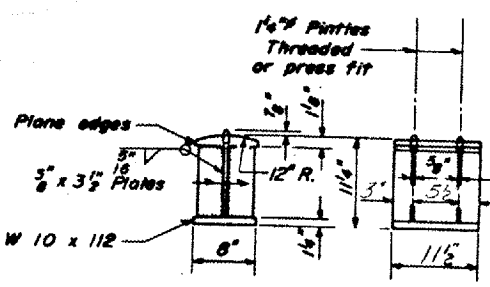

DESIGNED	J.F.P.	DATE	11/17/73
CHECKED	J.F.P.	EXAMINED	J.F.P.
DRAWN	J.F.P.	APPROVED	J.F.P.
CHECKED	J.F.P.	APPROVED	J.F.P.

FOR INFORMATION ONLY:
 BRIDGE NO. 9 STRUCTURE 064-0038