

ILL. 43 (WAUKEGAN ROAD)

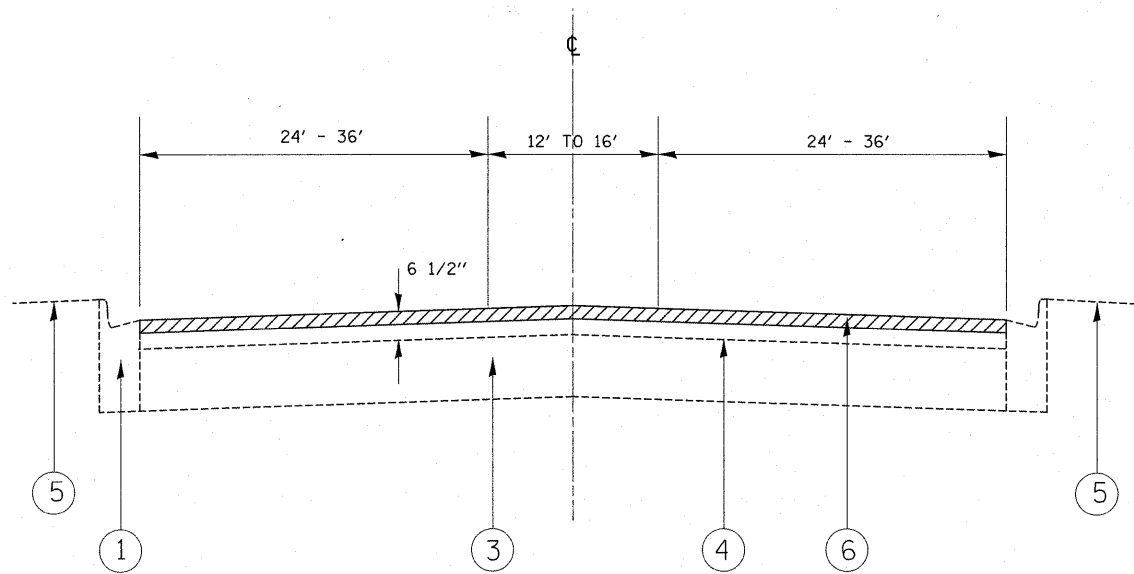

EXISTING TYPICAL SECTION
ILL. 43 (WAUKEGAN ROAD)
STA. 33+00 TO STA. 44+00

LEGEND:

- ① EXISTING B-6.12 CURB & GUTTER
- ② EXISTING HMA BASE COURSE, 9" (±)
- ③ EXISTING PCC BASE COURSE, 9" (±)
- ④ EXISTING HOT-MIX ASPHALT SURFACE, 6 1/2" (±)
- ⑤ EXISTING ASPHALT SHOULDER OR SODDING. (18" TO BE REMOVED AND REPLACED IN AREAS WITH NEW CURB AND GUTTER)
- ⑥ PROPOSED HOT-MIX ASPHALT SURFACE REMOVAL, 2 1/2"
- ⑦ PROPOSED POLYMERIZED LEVELING BINDER (MACHINE METHOD), IL-4.75, N50, 3/4"
- ⑧ PROPOSED POLYMERIZED HOT-MIX ASPHALT SURFACE COURSE, MIX "F", N90, 1 3/4"

ILL. 43 (WAUKEGAN ROAD)

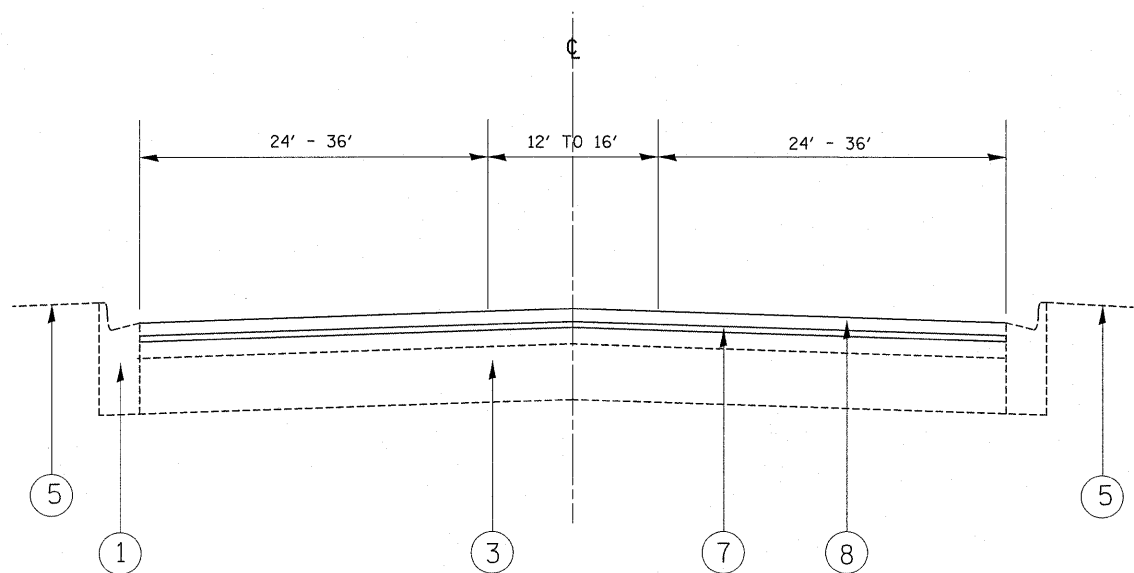

PROPOSED TYPICAL SECTION
ILL. 43 (WAUKEGAN ROAD)
STA. 33+00 TO STA. 44+00

- NOTE 1: CONCRETE MEDIAN LOCATED BETWEEN STA. 5+30 TO STA. 10+20 AND STA. 77+82 TO STA. 78+40
- NOTE 2: MILLING TO BE DONE BEFORE PATCHING

FILE NAME =	USER NAME = banks1	DESIGNED -	REVISED -	STATE OF ILLINOIS DEPARTMENT OF TRANSPORTATION	ILL 43 (WAUKEGAN ROAD) - PULASKI DRIVE TO MARTIN LUTHER KING DRIVE TYPICAL SECTIONS	F.A.U. RTE.	SECTION	COUNTY	TOTAL SHEETS	SHEET NO.	
cr\pw_work\pwsdot\banks1\d0211622\015251	sh-t-plan.dgn	DRAWN -	REVISED -			2706	126 RS-6	LAKE	24	5	
PLOT SCALE = 50.0000' / IN.		CHECKED -	REVISED -			SCALE: SHEET NO. OF SHEETS STA. TO STA.		CONTRACT NO. 60K56			
PLOT DATE = 1/20/2011		DATE -	REVISED -			ILLINOIS FED. AID PROJECT					