

EXISTING TYPICAL CROSS SECTION
IL RTE. 83 (CALUMET SAG RD.) (US RTE. 45 TO HIGHWOOD DR.)

STA. 10+88 TO STA. 21+30
 STA. 22+10 TO STA. 23+24

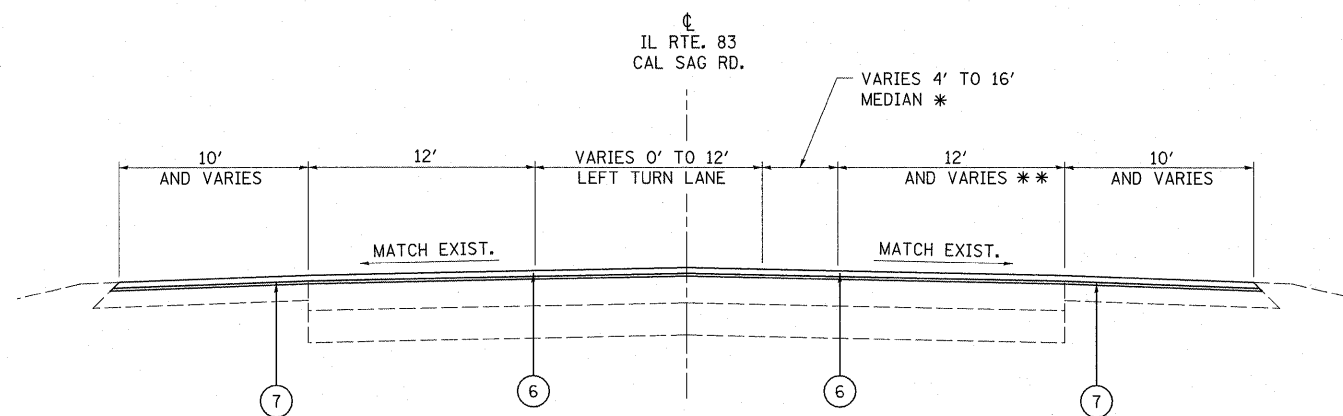

PROPOSED TYPICAL CROSS SECTION
IL RTE. 83 (CALUMET SAG RD.) (US RTE. 45 TO HIGHWOOD DR.)

STA. 10+88 TO STA. 21+30
 STA. 22+10 TO STA. 23+24

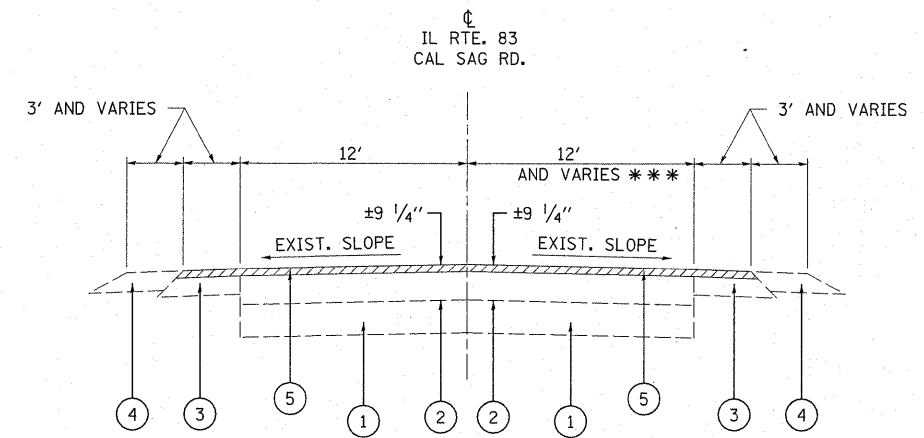

EXISTING TYPICAL CROSS SECTION
IL RTE. 83 (CALUMET SAG RD.) (US RTE. 45 TO HIGHWOOD DR.)

STA. 23+24 TO STA. 96+65

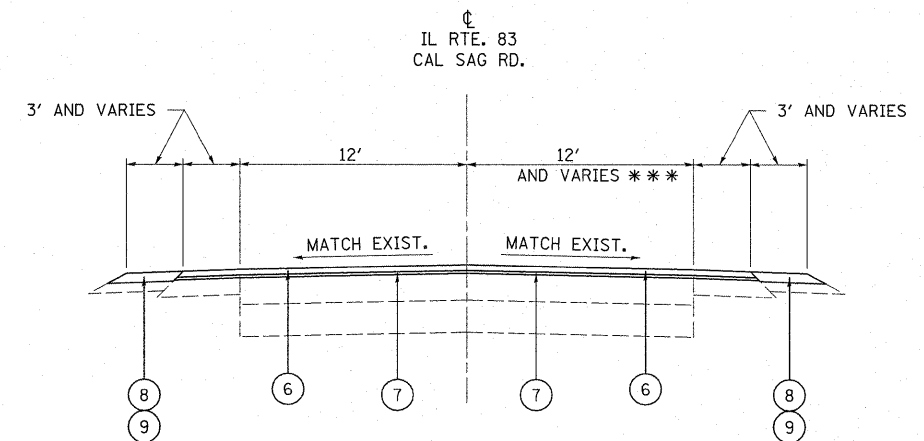

PROPOSED TYPICAL CROSS SECTION
IL RTE. 83 (CALUMET SAG RD.) (US RTE. 45 TO HIGHWOOD DR.)

STA. 23+24 TO STA. 96+65

LEGEND

- ① EXISTING P.C.C. PAVEMENT, ± 8"
- ② EXISTING H.M.A. PAVEMENT, ± 9 1/4"
- ③ EXISTING H.M.A. SHOULDER
- ④ EXISTING AGGREGATE SHOULDER
- ⑤ PROPOSED H.M.A. SURFACE REMOVAL, 2 1/4"
- ⑥ PROPOSED HOT-MIX ASPHALT SURFACE COURSE, MIX "D", N70, 1 1/2"
- ⑦ PROPOSED POLYMERIZED LEVELING BINDER (MACHINE METHOD), IL-4.75, N50, 3/4"
- ⑧ PROPOSED AGGREGATE WEDGE SHOULDER, TYPE B
- ⑨ PROPOSED GRADING AND SHAPING SHOULDERS

NOTES

- * EXISTING CONCRETE MEDIAN FROM STA. 10+88 TO STA. 13+00
 - EXIST. CONCRETE MEDIAN SURFACE 4" TO REMAIN
 - EXIST. COMB. CONC. CURB & GUTTER TYPE M-6.06 TO REMAIN
- ** RIGHT TURN LANE FROM APPROX. STA. 10+88 TO STA. 13+00
- *** RIGHT TURN LANE FROM APPROX. STA. 34+00 TO STA. 38+88

OMISSION

FROM STA. 21+30 TO STA. 22+10.

PATCHING SEQUENCE OF CONSTRUCTION

PAVEMENT PATCHING SHALL BE DONE AFTER ROADWAY MILLING AS PER THE BD-22 DETAIL.

HOT-MIX ASPHALT MIXTURE REQUIREMENTS

MIXTURE TYPE	AIR VOIDS
PAVEMENT RESURFACING	
HOT-MIX ASPHALT SURFACE COURSE, MIX "D", N70, (IL-9.5 mm)	4% @ 70 GYR.
POLYMERIZED LEVELING BINDER (MACHINE METHOD), IL-4.75, N50	4% @ 50 GYR.
PATCHING	
CLASS D PATCHES (HMA BINDER IL-19 mm), 15"	4% @ 70 GYR.

NOTES:

THE UNIT WEIGHT USED TO CALCULATE ALL HMA SURFACE MIXTURE QUANTITIES IS 112 LBS/SQ YD/IN.

THE "AC TYPE" FOR POLYMERIZED HMA MIXES SHALL BE "SBS/SBR PG 70-22" AND FOR NON-POLYMERIZED HMA THE "AC TYPE" SHALL BE "PG 64-22" UNLESS MODIFIED BY DISTRICT ONE SPECIAL PROVISIONS. FOR "PERCENT OF RAP" SEE DISTRICT ONE SPECIAL PROVISIONS.