

WITH INTERSECTION TRAFFIC SIGNALS

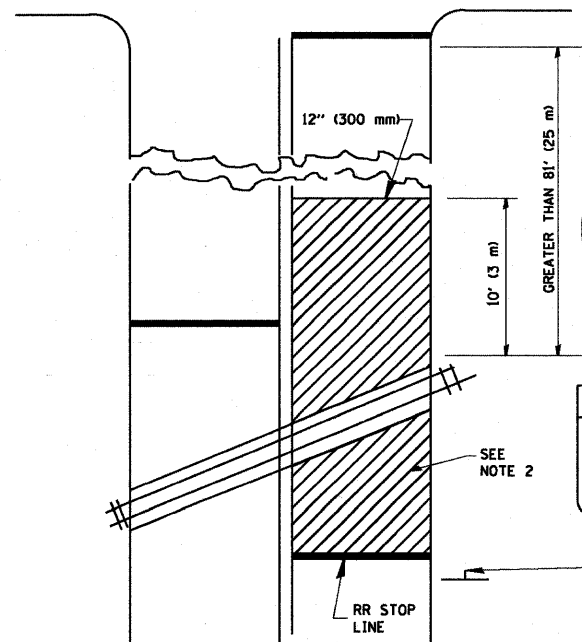

WITH NEAR-SIDE TRAFFIC SIGNALS

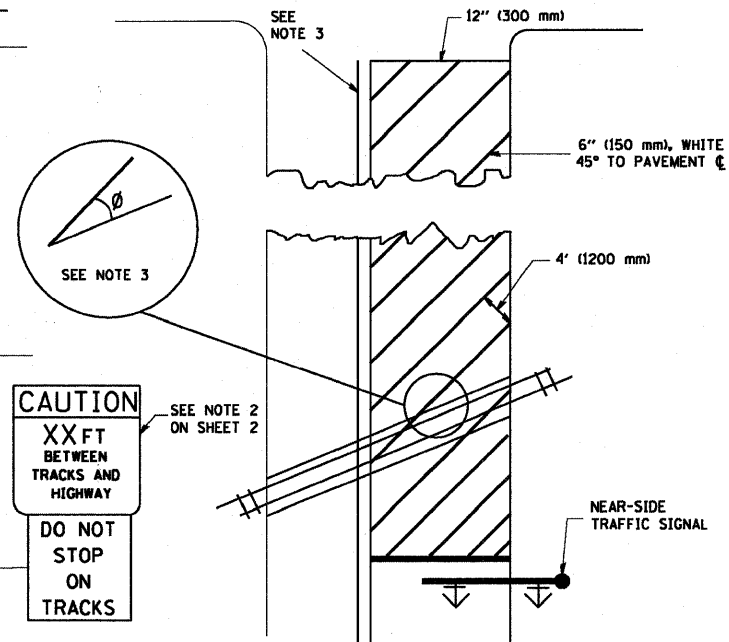

WITH NONSIGNALIZED INTERSECTION  
81' (25 m) OR LESS TO CLOSEST RAIL

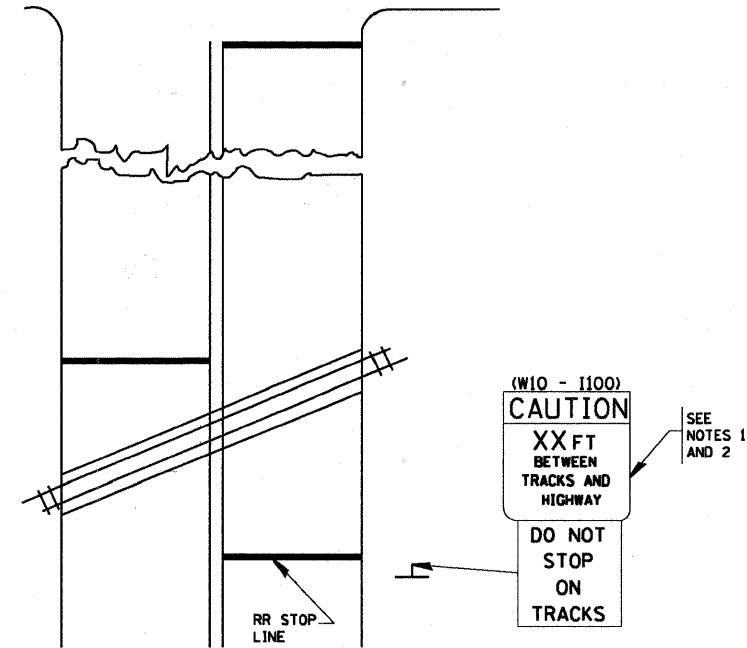

**NOTES:**

- PAVEMENT MARKINGS TO BE INSTALLED ONLY ON APPROACHES TO INTERSECTIONS CONTROLLED BY TRAFFIC SIGNALS WHICH ARE INTERCONNECTED WITH THE RAILROAD WARNING SIGNALS.
- WHERE NEAR-SIDE TRAFFIC SIGNALS ARE USED, THE PAVEMENT MARKINGS EXTENDS TO THE INTERSECTION.
- WHERE THE ANGLE BETWEEN THE DIAGONAL STRIPES AND THE TRACK (Ø) WOULD BE LESS THAN APPROXIMATELY 20°, THE STRIPES SHOULD BE SLOPED IN THE OPPOSITE DIRECTION FROM THAT SHOWN.

**NOTE 1**

- DISTANCE TO BE SHOWN ON SIGN MEASURED FROM A POINT 6 FEET (1.8 m) FROM THE RAIL CLOSEST TO THE INTERSECTION TO THE STOP LINE OR CROSSWALK, WHICHEVER IS CLOSEST, ROUNDED DOWN TO THE NEAREST 5 FEET (1.5 m). WHERE THERE IS NO STOP LINE, MEASURE TO POINT WHERE THE DRIVER HAS A VIEW OF APPROACHING TRAFFIC.
- THE CLEARANCE SIGN IS ALSO TO BE USED AS AN INTERIM MEASURE AT LOCATIONS WITH INTERCONNECTED INTERSECTION TRAFFIC SIGNALS WHERE IT IS PLANNED TO CHANGE THEM TO NEAR-SIDE SIGNALS AT A FUTURE TIME. IN THIS CASE, THE DISTANCE TO BE SHOWN ON THE SIGN IS MEASURED FROM THE EDGE OF THE STRIPED-OUT AREA INSTEAD OF 6 FEET FROM THE RAIL. THE SIGN IS TO BE REMOVED WHEN THE NEAR-SIDE SIGNALS ARE INSTALLED AND THE PAVEMENT MARKINGS EXTEND TO THE INTERSECTION.

ALL DIMENSIONS ARE IN INCHES (MILLIMETERS) UNLESS OTHERWISE SHOWN.

FILE NAME = W:\dists\td\22x34\to23.dgn	USER NAME = geglianobt	DESIGNED -	REVISED - 01-01-07	<b>STATE OF ILLINOIS DEPARTMENT OF TRANSPORTATION</b>	<b>TYPICAL SUPPLEMENTAL SIGNING AND PAVEMENT MARKING TREATMENT FOR RAILROAD CROSSINGS</b>			F.A.U. RTE.	SECTION	COUNTY	TOTAL SHEETS	SHEET NO.	
	PLOT SCALE = 50,000' / IN.	DRAWN -	REVISED -		SCALE: NONE	SHEET NO. 1 OF 1 SHEETS	STA.	TO STA.	116	06-00104-01-WR	MCHENRY	64	46
	PLOT DATE = 1/4/2008	CHECKED -	REVISED -						<b>TC-23</b>		<b>CONTRACT NO. 63524</b>		
		DATE -	REVISED -						<small>FED. ROAD DIST. NO. 1 ILLINOIS FED. AID PROJECT</small>				