

SECTION A-A

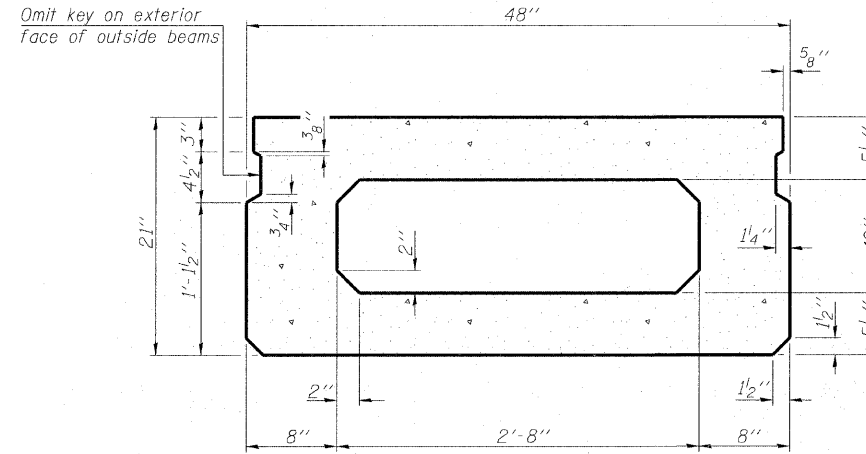

SECTION B-B
(Showing dimensions)

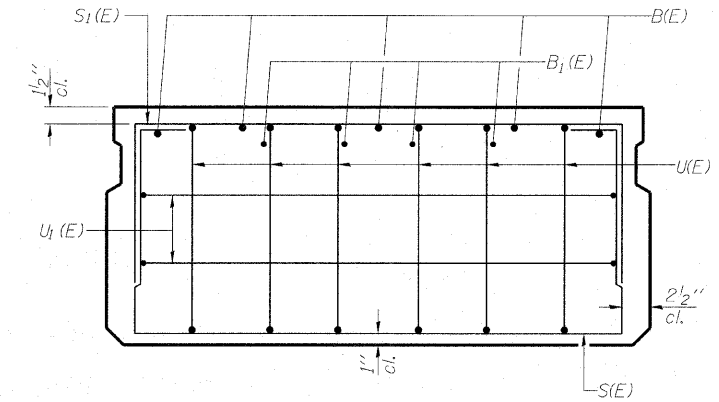

VIEW C-C

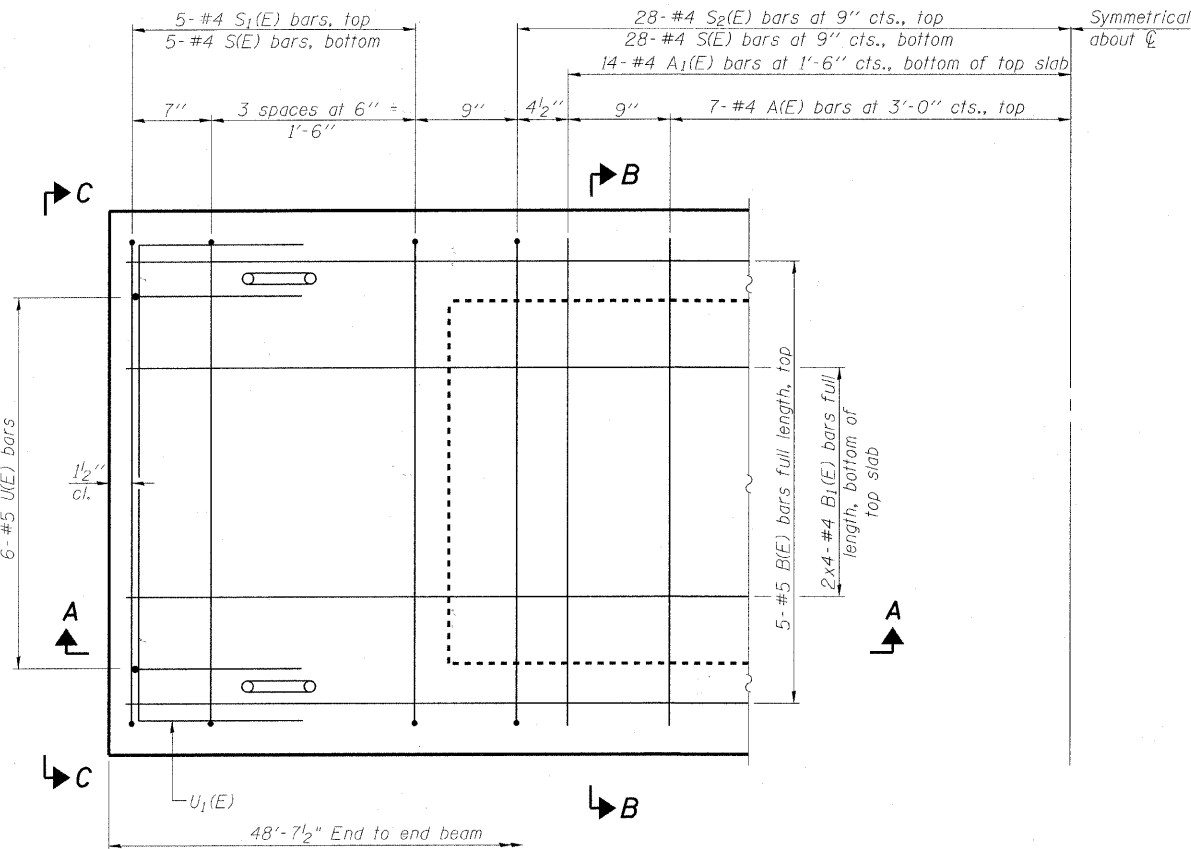

PLAN VIEW

Note: Spacing of S(E) and S2(E) bars may be adjusted up to 4" in the immediate area of the transverse tie diaphragms to miss the block outs for the transverse ties.

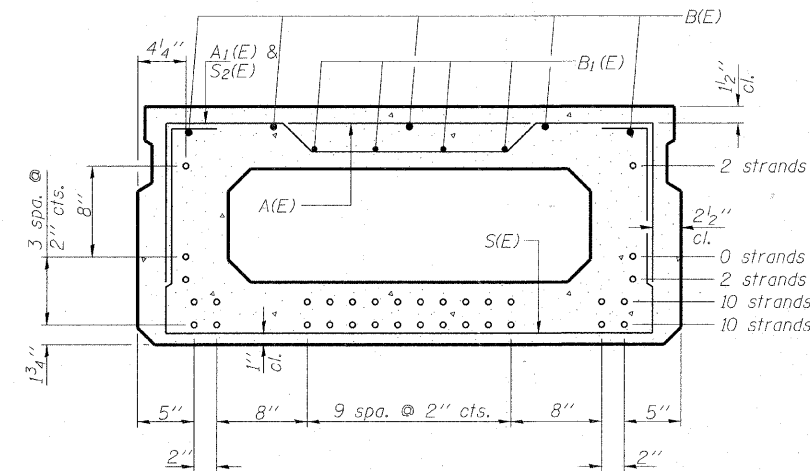

SECTION B-B

(Showing reinforcement and permissible strand locations)
Note: Place the number of strands specified in each row symmetrically about the centerline of beam in the permissible strand locations shown.

BAR LIST
ONE BEAM ONLY
(For Information Only)

Bar	No.	Size	Length	Shape
A(E)	14	#4	3'-7"	—
A1(E)	28	#4	3'-10"	—
B(E)	5	#5	48'-4"	—
B1(E)	8	#4	25'-2"	—
S(E)	56	#4	7'-5"	□
S1(E)	10	#4	5'-11"	□
S2(E)	56	#4	6'-2"	□
U(E)	12	#5	4'-0"	□
U1(E)	4	#4	6'-0"	□

Note: See sheet 4 of 19 for additional details and Bill of Material.

MINIMUM BAR LAP

#4 bar = 2'-0"
#5 bar = 2'-6"

COPYRIGHT © 2000 BY BRAYTES & WOODMAN, INC.
 ALL RIGHTS RESERVED. NO PART OF THIS PUBLICATION MAY BE REPRODUCED OR TRANSMITTED IN ANY FORM OR BY ANY MEANS, ELECTRONIC OR MECHANICAL, WITHOUT PERMISSION IN WRITING FROM BRAYTES & WOODMAN, INC.
 LICENSE NO. 0000000000 - EXPIRES 12/31/2010
 393467 P11

FILE NAME =	USER NAME =	DESIGNED - BLB	REVISED - PER MCDOT 12/31/10
		CHECKED - BAB	REVISED -
	PLOT SCALE =	DRAWN - BCD	REVISED -
	PLOT DATE =	CHECKED - BLB	REVISED -

MCHENRY COUNTY DIVISION OF TRANSPORTATION
GRAF ROAD BRIDGE OVER
LAWRENCE CREEK

21" x 48" PPC DECK BEAM
STRUCTURE NO. 056-3182

SHEET NO. 3 OF 19 SHEETS

TR	SECTION	COUNTY	TOTAL SHEETS	SHEET NO.
0037	06-00322-00-BR	MCHENRY	54	26
C-91-358-06		CONTRACT NO. 63569		
FED. ROAD DIST. NO. 1 ILLINOIS FED. AID PROJECT				BROS-0001(683)