

TOP PLAN

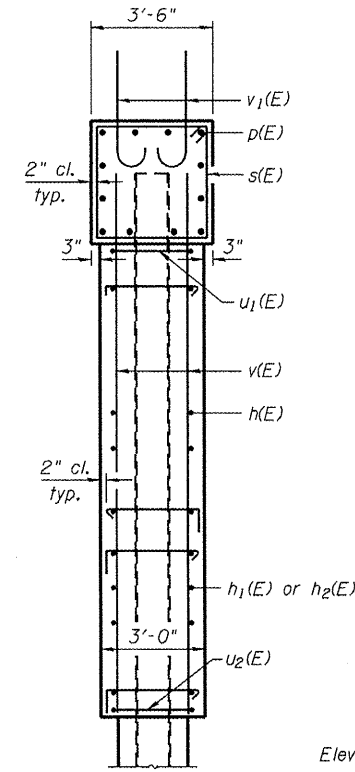

END VIEW

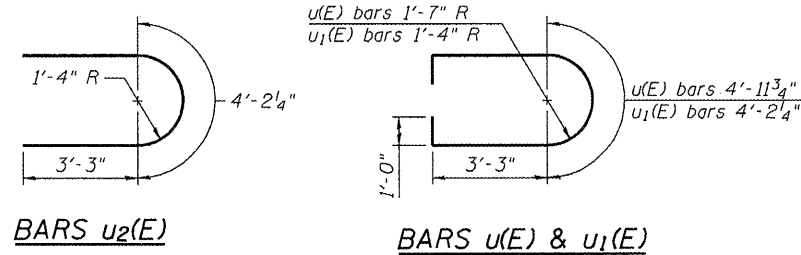
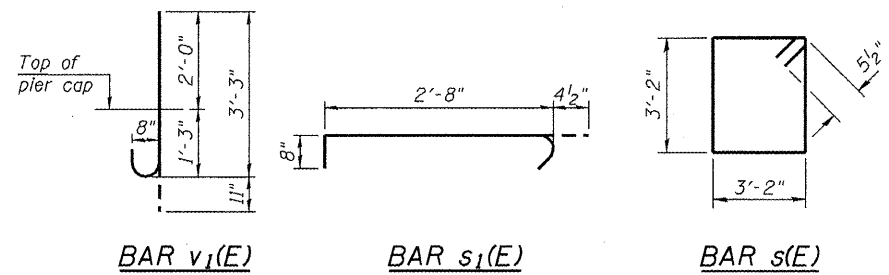
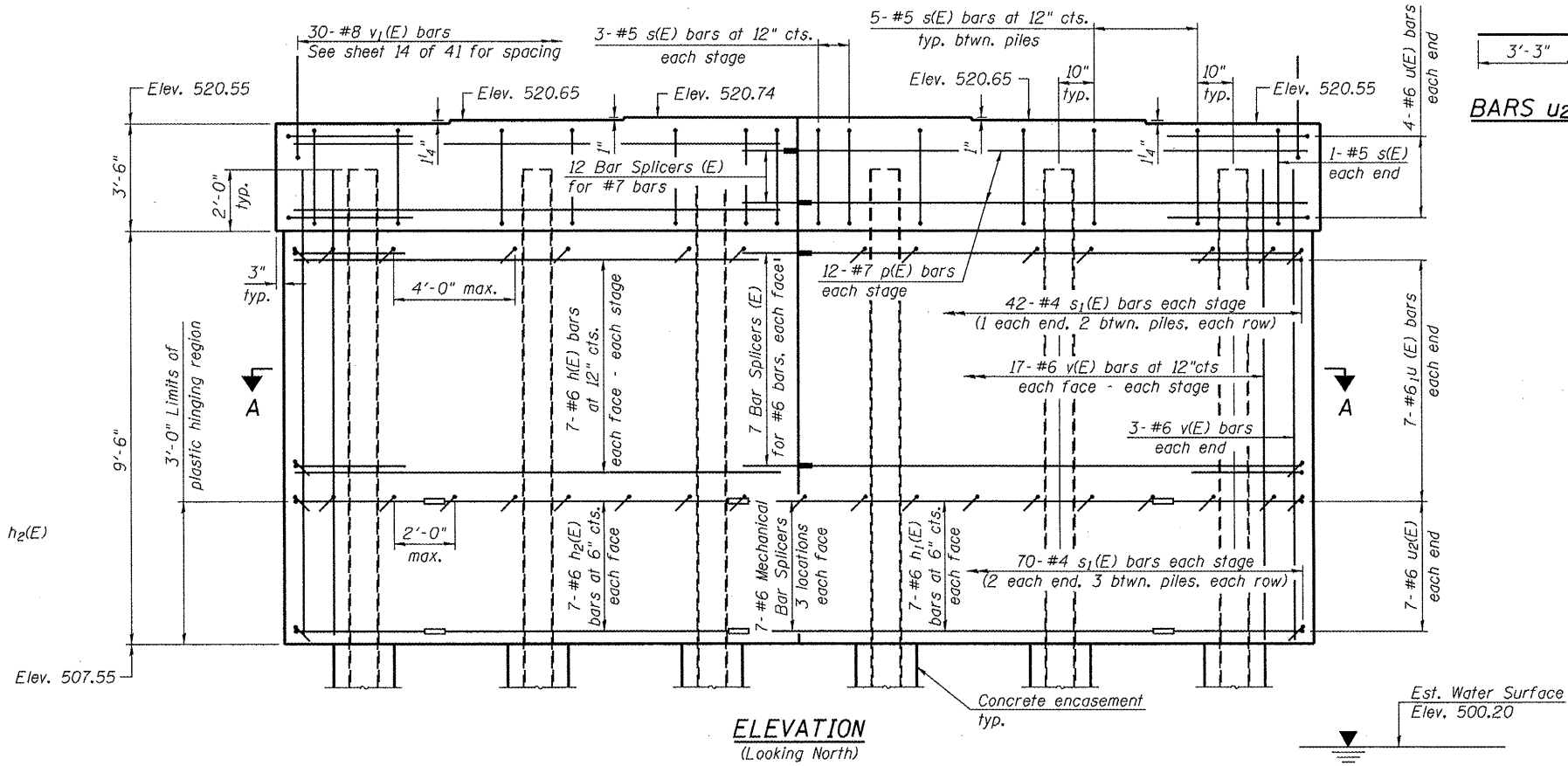

ELEVATION
(Looking North)

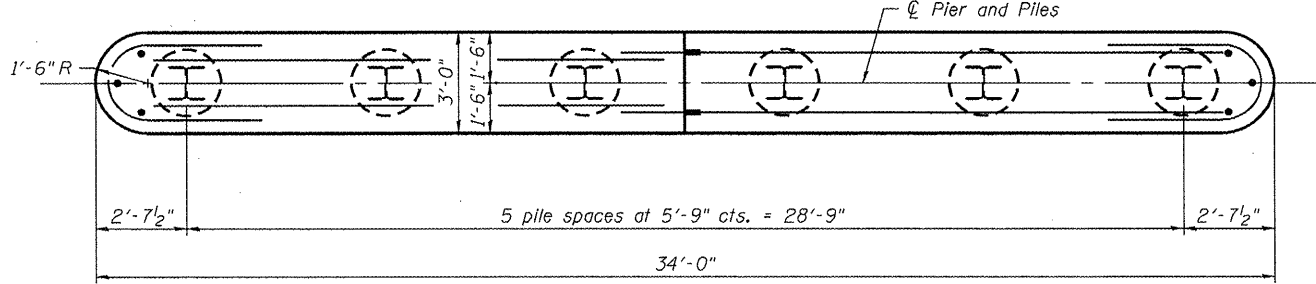

SECTION A-A

PIER 1
BILL OF MATERIAL

Bar	No.	Size	Length	Shape
h(E)	28	#6	15'-4"	—
h1(E)	14	#6	13'-3"	—
h2(E)	14	#6	11'-3"	—
p(E)	24	#7	15'-6"	—
s(E)	28	#5	13'-7"	□
s1(E)	224	#4	3'-9"	U
u(E)	8	#6	13'-6"	U
u1(E)	14	#6	12'-8"	U
u2(E)	14	#6	10'-8"	U
v(E)	74	#6	11'-6"	—
v1(E)	30	#8	4'-2"	U
Structure Excavation		Cu. Yd.	34	
Concrete Structures		Cu. Yd.	51.0	
Concrete Encasement		Cu. Yd.	3.3	
Reinforcement Bars, Epoxy Coated		Pound	5,150	
Furnishing Steel Piles HP 14x102		Foot	385	
Driving piles		Foot	385	
Test Piles Steel HP 14x102		Each	1	
Pile Shoes		Each	6	

PILE DATA
 Type: HP 14x102 w/ Pile Shoes
 Nominal Required Bearing: 810 k
 Factored Resistance Available: 405 k
 Est. Length: 77'-0"
 No. Production Piles: 5
 No. Test Piles: 1

Notes:
 Pour steps monolithically with cap.
 For details of piles and encasement, see sheet 31 of 41.
 For details of Bar Splicers and Mechanical Splicers see sheet 32 of 41.