

STATE OF ILLINOIS
DEPARTMENT OF TRANSPORTATION
DIVISION OF HIGHWAYS

**PROPOSED
HIGHWAY PLANS**

FAS ROUTE 677 CH3 (OAKLAND-ASHMORE RD.)
SECTION (15-2,15-1,15,11)RS-1
PROJECT ACRS-0677(103)
RESURFACING
COLES COUNTY

C-97-026-11

F.A.S. RTE.	SECTION	COUNTY	TOTAL SHEETS	SHEET NO.
677	(15-2,15-1,15,11)RS-1	COLES	63	1
ILLINOIS			CONTRACT NO. 74507	

* 63-7 = 54

D-97-007-11

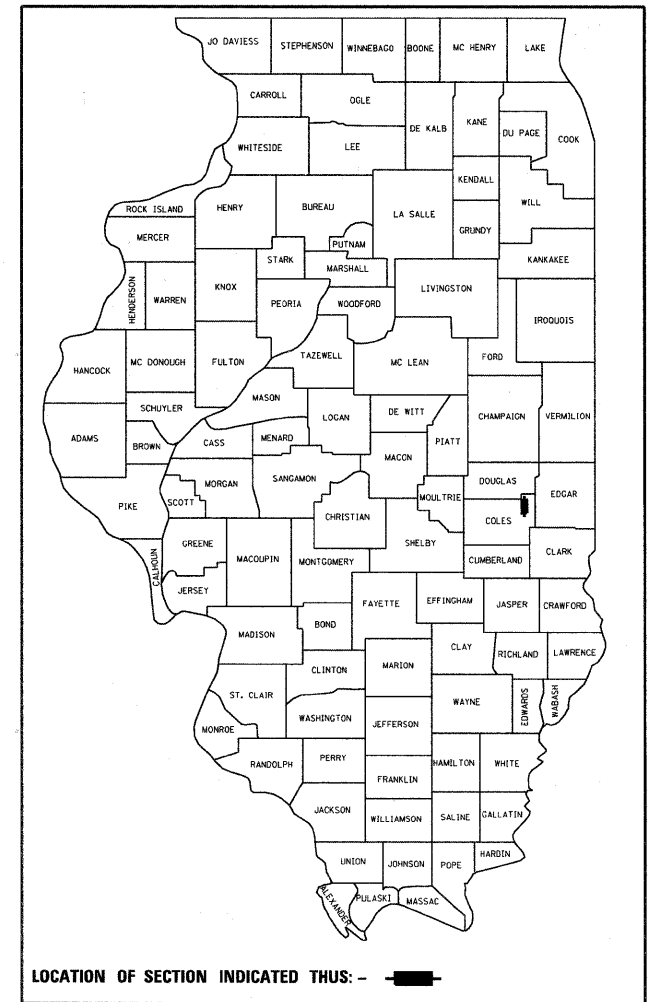

FOR INDEX OF SHEETS, SEE SHEET NO. 2

PAVING OMISSIONS:

STA. 349 + 34.54 TO STA. 351 + 86.46

STA. 480 + 89.50 TO STA. 480 + 98.60

ADT = 1400 (2009)



FAS ROUTE 677
SECTION (15-2,15-1,15,11)RS-1
COLES COUNTY
ENDS STA. 483 + 48.50

FAS ROUTE 677
SECTION (15-2,15-1,15,11)RS-1
COLES COUNTY
BEGINS STA. 50 + 04.50

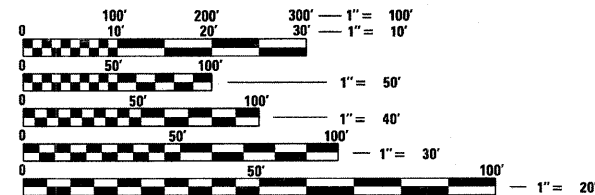

FULL SIZE PLANS HAVE BEEN PREPARED USING STANDARD ENGINEERING SCALES. REDUCED SIZED PLANS WILL NOT CONFORM TO STANDARD SCALES. IN MAKING MEASUREMENTS ON REDUCED PLANS, THE ABOVE SCALES MAY BE USED.

J.U.L.I.E.
JOINT UTILITY LOCATION INFORMATION FOR EXCAVATION
1-800-892-0123
OR 811

PROJECT ENGINEER: TOM RONAN
PROJECT MANAGER: NEIL SANDSCHAFFER

CONTRACT NO. 74507

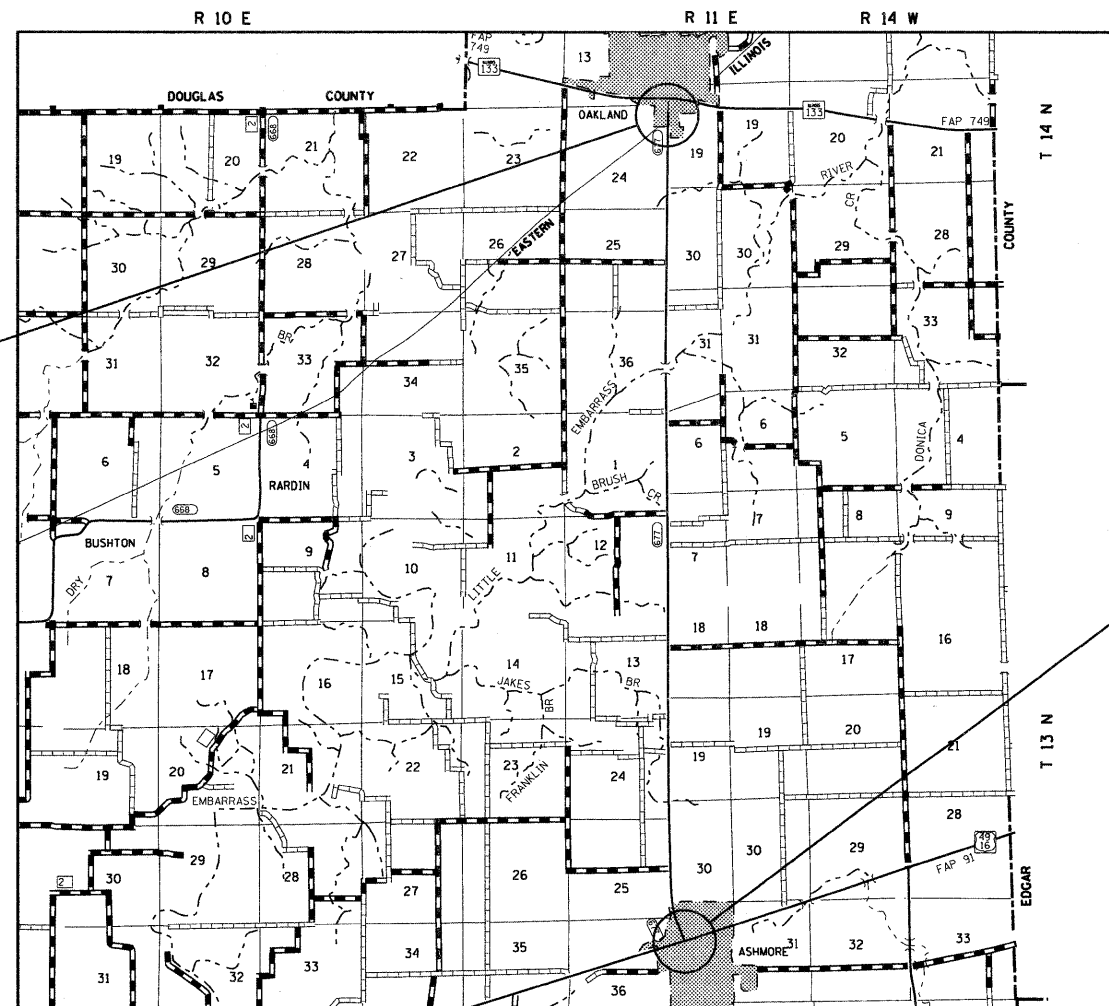

GROSS LENGTH = 43,344.0 FT. = 8.21 MILE
NET LENGTH = 43,083.0 FT. = 8.16 MILE

STATE OF ILLINOIS
DEPARTMENT OF TRANSPORTATION
DIVISION OF HIGHWAYS

SUBMITTED Jan 31 20 11
Donnell
DEPUTY DIRECTOR OF HIGHWAYS, REGION ENGINEER

March 25 20 11
Scott E. Still, P.E.
Acting ENGINEER OF DESIGN AND ENVIRONMENT

March 25 20 11
Christine M. Reed
DIRECTOR OF HIGHWAYS, CHIEF ENGINEER

**PRINTED BY THE AUTHORITY
OF THE STATE OF ILLINOIS**

INDEX OF SHEETS

SHEET NO.	ITEM
1	COVER SHEET
2	INDEX OF SHEETS
3	GENERAL NOTES
4	SUMMARY OF QUANTITIES
5-8	EXISTING TYPICAL SECTIONS
9-12	PROPOSED TYPICAL SECTIONS
13-14	CONSTRUCTION DETAILS
15-16	SCHEDULE OF QUANTITIES
17	ENTRANCE SCHEDULE
18-19	TIE POINTS
20-34	PLAN SHEETS
35-38	STAGE CONSTRUCTION - SN 015-0036
39-48	BRIDGE REPAIR PLANS
58-63	DISTRICT DETAILS

58-63 → SHEETS 49 THRU 57 NOT USED
 THE FOLLOWING STANDARDS ARE A PART OF THESE PLANS AND ARE INCLUDED AFTER SHEET NO. 63:

STD. NO.	DESCRIPTION
000001-06	STANDARD SYMBOLS, ABBREVIATIONS AND PATTERNS
001001-02	AREAS OF REINFORCEMENT BARS
001006	DECIMAL OF AN INCH AND OF A FOOT
420001-07	PAVEMENT JOINTS
442201-03	CLASS C AND D PATCHES
482011-03	HMA SHLD. STRIPS/SHLDS. WITH RESURFACING OR WIDENING AND RESURFACING PROJECTS
701001-02	OFF-ROAD OPERATIONS, 2L, 2W, MORE THAN 15' AWAY
701006-03	OFF-RD OPERATIONS, 2L, 2W, 15' TO 24" FROM PAVEMENT EDGE
701011-02	OFF-RD MOVING OPERATIONS, 2L, 2W, DAY ONLY
701201-04	LANE CLOSURE, 2L, 2W, DAY ONLY, FOR SPEEDS >= 45 MPH
701301-04	LANE CLOSURE, 2L, 2W, SHORT TIME OPERATIONS
701306-03	LANE CLOSURE, 2L, 2W, SLOW MOVING OPERATIONS DAY ONLY, FOR SPEEDS >= 45 MPH
701311-03	LANE CLOSURE 2L, 2W, MOVING OPERATIONS - DAY ONLY
701321-11	LANE CLOSURE, 2L, 2W, BRIDGE REPAIR WITH BARRIER
701336-06	LANE CLOSURE, 2L, 2W, WORK AREAS IN SERIES, FOR SPEEDS >= 45 MPH
701901-01	TRAFFIC CONTROL DEVICES
704001-06	TEMPORARY CONCRETE BARRIER
780001-02	TYPICAL PAVEMENT MARKINGS
781001-03	TYPICAL APPLICATIONS RAISED REFLECTIVE PAVEMENT MARKERS

GENERAL NOTES

THIS SECTION SHALL BE CONSTRUCTED IN ACCORDANCE WITH THE PLANS; THE "STANDARD SPECIFICATIONS FOR ROAD AND BRIDGE CONSTRUCTION", ADOPTED JANUARY 1, 2007; THE "SUPPLEMENTAL SPECIFICATIONS AND RECURRING SPECIAL PROVISIONS" INDICATED ON THE CHECK SHEET, AND "THE SPECIAL PROVISIONS" INCLUDED IN THE PROPOSAL.

THIS PROJECT IS LOCATED ON THE OAKLAND-ASHMORE BLACKTOP IN COLES COUNTY. THE PROJECT BEGINS AT ILLINOIS ROUTE 16 IN ASHMORE AND EXTENDS NORTH FOR 8.21 MILES TO ABOUT 715 FEET SOUTH OF ILLINOIS ROUTE 133. THE WORK INCLUDED IN SECTION (15-2,15-1,15,11)RS-1 CONSISTS OF PAVEMENT PATCHING, HOT-MIX ASPHALT SURFACE REMOVAL, HOT-MIX ASPHALT RESURFACING, SAFETY EDGE, AGGREGATE SHOULDERS, PAVEMENT MARKING, MINOR BRIDGE REPAIRS AND ANY OTHER WORK NECESSARY TO COMPLETE THE SECTION.

THE EXISTING PAVEMENT SHALL BE PATCHED IN ACCORDANCE WITH SECTION 442 OF THE STANDARD SPECIFICATIONS AND THE SPECIAL PROVISIONS. THE QUANTITY OF PATCHING SHOWN ON THE PLANS IS AN ESTIMATE ONLY. THE FINAL LOCATIONS AND QUANTITY SHALL BE DETERMINED BY THE ENGINEER IN THE FIELD.

WHEN PATCHING IN AREAS OF CONCRETE GUTTER, THE CLASS D PATCHES SHALL NOT EXTEND INTO THE CONCRETE WIDENING THAT IS POURED MONOLITHICALLY WITH THE CONCRETE GUTTER. THE DIMENSIONS OF THE EXISTING CONCRETE WIDENED AREAS CAN BE FOUND USING THE EXISTING TYPICAL SECTIONS AS A GUIDE. THE CONTRACTOR SHALL NOT DAMAGE THE CONCRETE WIDENING AND/OR CONCRETE GUTTER WHILE PATCHING IN CONCRETE GUTTER AREAS.

THE CONTRACTOR SHALL USE EITHER, RC-70, SS-1HP, OR SS1H APPLIED AT THE RATE DIRECTED BY THE ENGINEER, FOR THE PAY ITEM BITUMINOUS MATERIALS (PRIME COAT).

THE CONTRACTOR SHALL PROVIDE INTERNET ACCESSIBILITY TO THE HOT-MIX ASPHALT PLANT QUALITY CONTROL LAB SO THAT HOT-MIX ASPHALT PLANT REPORTS CAN BE E-MAILED TO THE DISTRICT HEADQUARTERS. THIS WORK SHALL BE INCLUDED IN THE COST OF ALL HOT-MIX ASPHALT ITEMS.

THE PAY ITEM TEMPORARY RAMP HAS BEEN INCLUDED FOR THE CONSTRUCTION OF TEMPORARY RAMPS IN ACCORDANCE WITH ARTICLE 406.08 OF THE STANDARD SPECIFICATIONS. THE COST SHALL INCLUDE BOTH THE INSTALLATION AND THE REMOVAL OF THE TEMPORARY RAMPS.

IN THE PROPOSED INLAY AREAS, THE EDGE OF THE EXISTING CONCRETE GUTTER SHALL CONTROL THE DEPTH OF THE HOT-MIX ASPHALT SURFACE REMOVAL, 2". NO ADDITIONAL COMPENSATION WILL BE ALLOWED FOR INCREASED MILLING DEPTHS CAUSED BY EXISTING RESURFACING ABOVE THE EDGES OF THE CONCRETE GUTTER. THIS WORK SHALL BE PAID FOR AT THE CONTRACT UNIT PRICE PER SQUARE YARD FOR HOT-MIX ASPHALT SURFACE REMOVAL, 2".

LANE DIFFERENTIALS OF 2" OR GREATER WILL NOT BE ALLOWED TO BE OPENED TO TRAFFIC.

TEMPORARY RAMPS WILL BE REQUIRED, AT SIDE ROADS AND ENTRANCES, AFTER THE HOT-MIX ASPHALT SURFACE REMOVAL, 2" HAS BEEN PERFORMED. THE CONTRACTOR SHALL CONSTRUCT THE TEMPORARY RAMPS A MAXIMUM OF 1 FOOT IN LENGTH. THIS WORK WILL BE PAID FOR AT THE CONTRACT UNIT PRICE PER SQUARE YARD FOR TEMPORARY RAMPS (SPECIAL). THE COST SHALL INCLUDE BOTH THE INSTALLATION AND THE REMOVAL OF THE TEMPORARY RAMPS.

A UNIFORMLY STRAIGHT SAW CUT SHALL BE MADE AT LOCATIONS WHERE PROPOSED NEW CONSTRUCTION WILL ABUT EXISTING HOT-MIX ASPHALT SURFACES. THE SAW CUT SHALL BE MADE THE SAME DEPTH AS THE HOT-MIX ASPHALT SURFACE REMOVAL. THIS WORK WILL BE CONSIDERED INCLUDED IN THE COST OF THE CONTRACT ITEMS INVOLVED AND NO EXTRA COMPENSATION WILL BE ALLOWED.

THE CONTRACTOR SHALL MAINTAIN DRAINAGE THROUGHOUT THE PROJECT PAYING SPECIAL ATTENTION TO ALL INLAY AREAS.

THE CONTRACTOR SHALL PROVIDE STEEL PLATING TO PROTECT THE INLETS NEAR SN 015-0036 AS WELL AS ANY SIGNS SHOWN ON THE STAGING PLANS. THESE ITEMS SHALL BE IN PLACE ANY TIME THE TEMPORARY TRAFFIC SIGNALS ARE REQUIRED. THE COST OF FURNISHING, INSTALLING, MAINTAINING, AND REMOVING THESE ITEMS WILL BE INCLUDED IN THE CONTRACT BID PRICE FOR TRAFFIC CONTROL AND PROTECTION, STANDARD 701321.

DURING RESURFACING OPERATIONS IN ASHMORE AND OAKLAND, THE CONTRACTOR SHALL NOT OPERATE ROLLERS IN THE DYNAMIC MODE. ALL DENSITY REQUIREMENTS WILL REMAIN THE SAME.

THE RESIDENT ENGINEER SHALL BE THE SOLE JUDGE CONCERNING THE CURING TIME FOR THE HOT-MIX ASPHALT LEVELING BINDER AND SURFACE COURSE.

THE MATERIAL USED FOR AGGREGATE SHOULDERS, TYPE B SHALL BE CRUSHED STONE, CRUSHED CONCRETE, OR RAP. THE MATERIAL USED FOR AGGREGATE SURFACE COURSE, TYPE B SHALL BE CRUSHED STONE OR CRUSHED CONCRETE.

SHOULD A PERMANENT SURVEY MARKER BE DISTURBED DURING CONSTRUCTION OPERATIONS, THE CONTRACTOR SHALL BE RESPONSIBLE FOR HAVING THE PERMANENT SURVEY MARKER RE-ESTABLISHED IN THE PROPER LOCATION BY A REGISTERED LAND SURVEYOR.

PAVEMENT MARKING SHALL BE APPLIED IN ACCORDANCE WITH SECTION 780 OF THE STANDARD SPECIFICATIONS. SHORT TERM PAVEMENT MARKING SHALL BE APPLIED TO THE MILLED SURFACE, BITUMINOUS MATERIALS (PRIME COAT), HOT-MIX ASPHALT LEVELING BINDER, AND HOT-MIX ASPHALT SURFACE COURSE AS SPECIFIED IN SECTION 703 OF THE STANDARD SPECIFICATIONS. TEMPORARY TAPE SHALL BE USED ON THE SURFACE COURSE AND PAINT SHALL BE USED ON THE MILLED SURFACES.

THE TOTAL QUANTITY OF RAISED REFLECTIVE PAVEMENT MARKERS IS 540 TWO-WAY AMBER MARKERS.

GENERAL NOTES (Cont' d)

THE FOLLOWING MIXTURE REQUIREMENTS ARE APPLICABLE TO THIS PROJECT:

SURFACE COURSE (1 1/2")

APPLICATION: HOT MIX ASPHALT SURFACE COURSE, MIX "C", N70
 PG GRADE: PG 64-22
 DESIGN AIR VOIDS: 4.0% @ NDESIGN = 70
 MIXTURE COMPOSITION: IL-9.5
 FRICTION AGGREGATE: MIXTURE C

LEVEL BINDER (3/4")

APPLICATION: LEVELING BINDER (MACHINE METHOD), N70
 PG GRADE: PG 64-22
 DESIGN AIR VOIDS: 4.0% @ NDESIGN = 70
 MIXTURE COMPOSITION: IL- 9.5
 FRICTION AGGREGATE: N/A

INCIDENTAL SURFACING, (VAR.)

APPLICATION: HOT MIX ASPHALT SURFACE COURSE, MIX "C", N70
 PG GRADE: PG 64-22
 DESIGN AIR VOIDS: 4.0% @ NDESIGN = 70
 MIXTURE COMPOSITION: IL-9.5
 FRICTION AGGREGATE: MIXTURE C

PAVEMENT PATCHING

APPLICATION: HOT-MIX ASPHALT BINDER COURSE, IL-19.0, N70
 PG GRADE: PG 64-22
 DESIGN AIR VOIDS: 4.0% @ NDESIGN = 70
 MIXTURE COMPOSITION: IL- 19.0
 FRICTION AGGREGATE: N/A

THE FOLLOWING RATES OF APPLICATION HAVE BEEN USED IN CALCULATING PLAN QUANTITIES:

BITUMINOUS MATERIALS (PRIME COAT)	0.10 GAL/SQ YD
AGGREGATE (PRIME COAT)	4 LBS/SQ YD
HOT-MIX ASPHALT	112 LBS/SQ YD/INCH
GRANULAR MATERIAL	2.05 TONS/CU YD

FILE NAME = #FILE#	USER NAME = #USER#	DESIGNED -	REVISED -	STATE OF ILLINOIS DEPARTMENT OF TRANSPORTATION	GENERAL NOTES			F.A.S. RTE.	SECTION	COUNTY	TOTAL SHEETS	SHEET NO.
	PLOT SCALE = #SCALE#	DRAWN -	REVISED -		677	(15-2,15-1,15,11)RS-1	COLES	63	3			
PLOT DATE = #DATE#	CHECKED -	REVISED -	SCALE: NA		SHEET NO. 1 OF 1 SHEETS		STA. TO STA.		CONTRACT NO. 74507			
	DATE -	REVISED -	ILLINOIS FED. AID PROJECT									

SUMMARY OF QUANTITIES			TOTAL QUANTITIES	80% FEDERAL CONSTRUCTION TYPE CODE 20% STATE	
CODE NO	ITEM	UNIT		0005	0014
20200600	EXCAVATING AND GRADING EXISTING SHOULDER	UNIT	751	751	
40200800	AGGREGATE SURFACE COURSE, TYPE B	TON	90	90	
40600100	BITUMINOUS MATERIALS (PRIME COAT)	GALLON	23032	23032	
40600300	AGGREGATE (PRIME COAT)	TON	231	231	
40600635	LEVELING BINDER (MACHINE METHOD), N70	TON	4810	4810	
40600895	CONSTRUCTING TEST STRIP	EACH	1	1	
40600990	TEMPORARY RAMP	SQ YD	147	147	
40603315	HOT-MIX ASPHALT SURFACE COURSE, MIX "C", N70	TON	10550	10550	
40800050	INCIDENTAL HOT-MIX ASPHALT SURFACING	TON	133	133	
44000155	HOT-MIX ASPHALT SURFACE REMOVAL, 1 1/2"	SQ YD	473	473	
44000157	HOT-MIX ASPHALT SURFACE REMOVAL, 2"	SQ YD	12280	12280	
44201690	CLASS D PATCHES, TYPE I, 4 INCH	SQ YD	9	9	
44201725	CLASS D PATCHES, TYPE I, 7 INCH	SQ YD	9	9	
44201773	CLASS D PATCHES, TYPE I, 11 INCH	SQ YD	7	7	
44201777	CLASS D PATCHES, TYPE II, 11 INCH	SQ YD	3979	3979	
44201781	CLASS D PATCHES, TYPE III, 11 INCH	SQ YD	1307	1307	
44201783	CLASS D PATCHES, TYPE IV, 11 INCH	SQ YD	379	379	
44201803	CLASS D PATCHES, TYPE II, 13 INCH	SQ YD	744	744	
44201807	CLASS D PATCHES, TYPE III, 13 INCH	SQ YD	80	80	
44201809	CLASS D PATCHES, TYPE IV, 13 INCH	SQ YD	894	894	
48101200	AGGREGATE SHOULDERS, TYPE B	TON	2594	2594	
50102400	CONCRETE REMOVAL	CU YD	7		7
50300255	CONCRETE SUPERSTRUCTURE	CU YD	7.8		7.8
50300260	BRIDGE DECK GROOVING	SQ YD	786		786
50300300	PROTECTIVE COAT	SQ YD	20		20
50500405	FURNISHING AND ERECTING STRUCTURAL STEEL	POUND	1340		1340
50800205	REINFORCEMENT BARS, EPOXY COATED	POUND	980		980
50800515	BAR SPLICERS	EACH	22		22
52000110	PREFORMED JOINT STRIP SEAL	FOOT	64		64
52100010	ELASTOMERIC BEARING ASSEMBLY, TYPE I	EACH	6		6
52100020	ELASTOMERIC BEARING ASSEMBLY, TYPE II	EACH	6		6
52100520	ANCHOR BOLTS, 1"	EACH	24		24
67000400	ENGINEER'S FIELD OFFICE, TYPE A	CAL MO	6	6	
67100100	MOBILIZATION	L SUM	1	1	
70100405	TRAFFIC CONTROL AND PROTECTION, STANDARD 701321	EACH	1		1

SUMMARY OF QUANTITIES (Cont'd)			TOTAL QUANTITIES	80% FEDERAL CONSTRUCTION TYPE CODE 20% STATE	
CODE NO	ITEM	UNIT		0005	0014
70100450	TRAFFIC CONTROL AND PROTECTION, STANDARD 701201	L SUM	1	1	
70100460	TRAFFIC CONTROL AND PROTECTION, STANDARD 701306	L SUM	1	1	
70100600	TRAFFIC CONTROL AND PROTECTION, STANDARD 701336	L SUM	1	1	
70103815	TRAFFIC CONTROL SURVEILLANCE	CAL DA	7	7	
70106500	TEMPORARY BRIDGE TRAFFIC SIGNALS	EACH	1		1
70106700	TEMPORARY RUMBLE STRIPS	EACH	6		6
70300100	SHORT TERM PAVEMENT MARKING	FOOT	17232	17232	
70300210	TEMPORARY PAVEMENT MARKING LETTERS AND SYMBOLS	SQ FT	123	123	
70300220	TEMPORARY PAVEMENT MARKING - LINE 4"	FOOT	103124	103124	
70300280	TEMPORARY PAVEMENT MARKING - LINE 24"	FOOT	66	66	
70301000	WORK ZONE PAVEMENT MARKING REMOVAL	SQ FT	1436	1436	
70400100	TEMPORARY CONCRETE BARRIER	FOOT	470		470
70400200	RELOCATE TEMPORARY CONCRETE BARRIER	FOOT	470		470
* 78000100	THERMOPLASTIC PAVEMENT MARKING - LETTERS AND SYMBOLS	SQ FT	123	123	
* 78000650	THERMOPLASTIC PAVEMENT MARKING - LINE 24"	FOOT	66	66	
* 78001110	PAINT PAVEMENT MARKING - LINE 4"	FOOT	103124	103124	
* 78100100	RAISED REFLECTIVE PAVEMENT MARKER	EACH	540	540	
X4060995	TEMPORARY RAMP, SPECIAL	SQ YD	63	63	
X4401198	HOT-MIX ASPHALT SURFACE REMOVAL, VARIABLE DEPTH	SQ YD	102406	102406	
XZ193500	BRIDGE DECK MICROSILICA CONCRETE OVERLAY 2 1/4"	SQ YD	825		825
Z0001899	JACK AND REMOVE EXISTING BEARINGS	EACH	12		12
Z0012130	BRIDGE DECK SCARIFICATION 3/4"	SQ YD	691		691
Z0016001	DECK SLAB REPAIR (FULL DEPTH, TYPE I)	SQ YD	7		7
Z0016002	DECK SLAB REPAIR (FULL DEPTH, TYPE II)	SQ YD	73		73
Z0021600	EXPANSION JOINT 4"	FOOT	64	64	
Z0030250	IMPACT ATTENUATORS, TEMPORARY (NON-REDIRECTIVE), TEST LEVEL 3	EACH	2		2
Z0030350	IMPACT ATTENUATORS, RELOCATE (NON-REDIRECTIVE), TEST LEVEL 3	EACH	2		2
Z0041895	POLYMER CONCRETE	CU FT	2.7		2.7
Z0048665	RAILROAD PROTECTIVE LIABILITY INSURANCE	L SUM	1	1	
Z0070100	SURVEY MONUMENT COVER ASSEMBLY	EACH	5	5	
Z0070202	SURVEY MARKER VAULT	EACH	6	6	

EXISTING TYPICAL CROSS SECTION

STATION 50+04.50 TO STATION 57+57.10

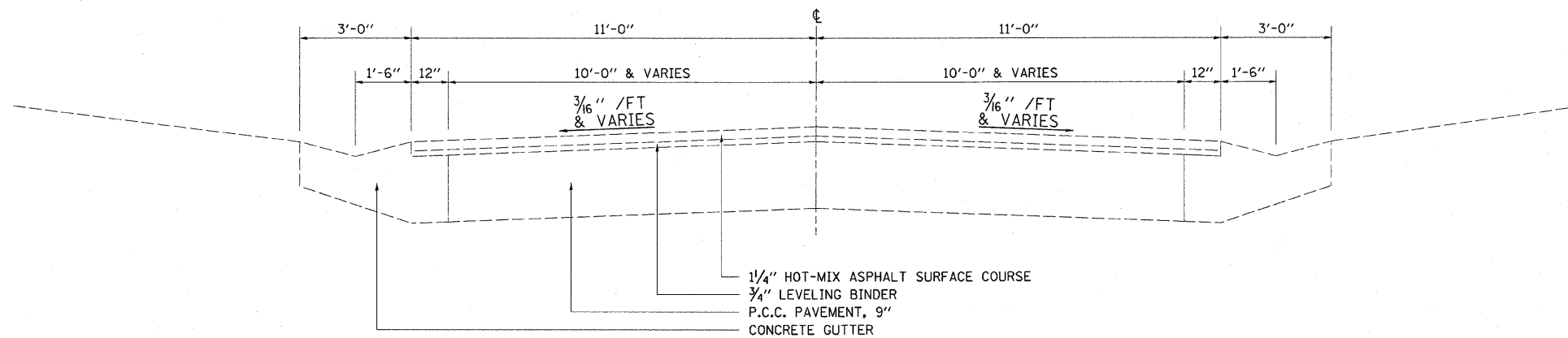

NOTE: NOT DRAWN TO SCALE

EXISTING TYPICAL CROSS SECTION

STATION 57+57.10 TO STATION 74+62.22

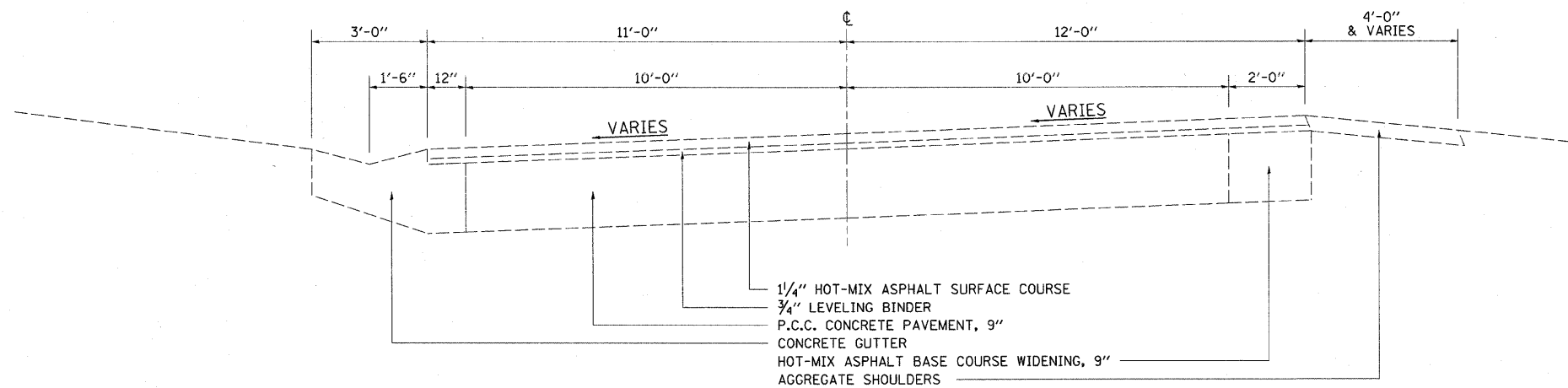

NOTE: NOT DRAWN TO SCALE

FILE NAME =	USER NAME = swartzw	DESIGNED -	REVISED -	STATE OF ILLINOIS DEPARTMENT OF TRANSPORTATION	EXISTING TYPICAL CROSS SECTION			F.A.S. RTE:	SECTION	COUNTY	TOTAL SHEETS	SHEET NO.	
et\pw\work\p\pidot\swartzw\d8242172\d77	507-sht-typicals.dgn	DRAWN -	REVISED -		SCALE: NA	SHEET NO. 1 OF 4 SHEETS	STA.	TO STA.	677	(15-2,15-1,15,11)RS-1	COLES	63	5
	PLOT SCALE = 20,0000 ' / IN.	CHECKED -	REVISED -										
	PLOT DATE = 1/31/2011	DATE -	REVISED -										
ILLINOIS FED. AID PROJECT													

EXISTING TYPICAL CROSS SECTION

STATION 74+62.22 TO STATION 211+34.00
 STATION 213+86.00 TO STATION 320+91.00
 STATION 364+27.00 TO STATION 416+60.00

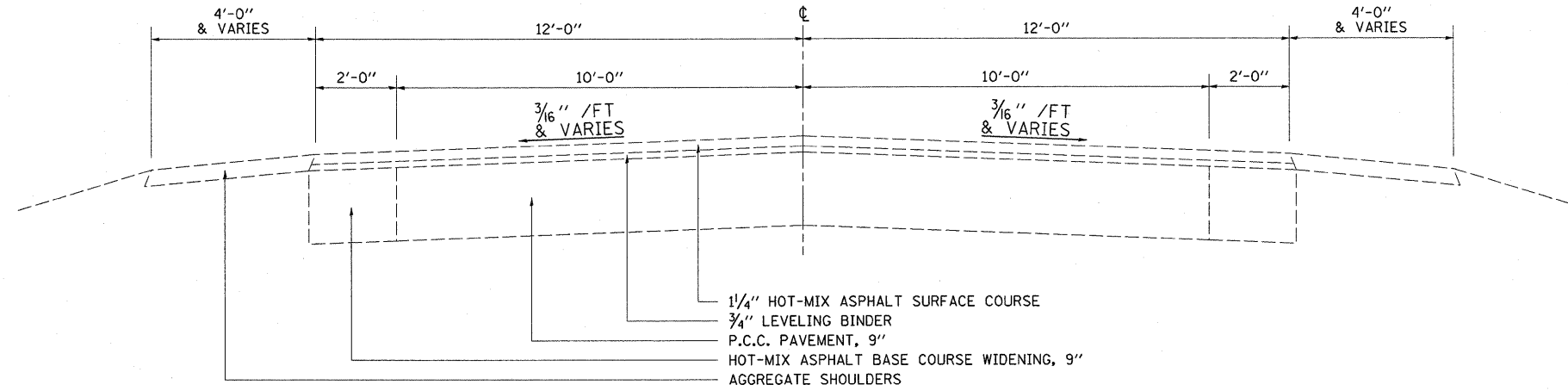

NOTE: NOT DRAWN TO SCALE

EXISTING TYPICAL CROSS SECTION

STATION 211+34.00 TO STATION 213+86.00
 STATION 320+91.00 TO STATION 334+16.00
 STATION 361+10.00 TO STATION 364+27.00
 STATION 416+60.00 TO STATION 472+00.00

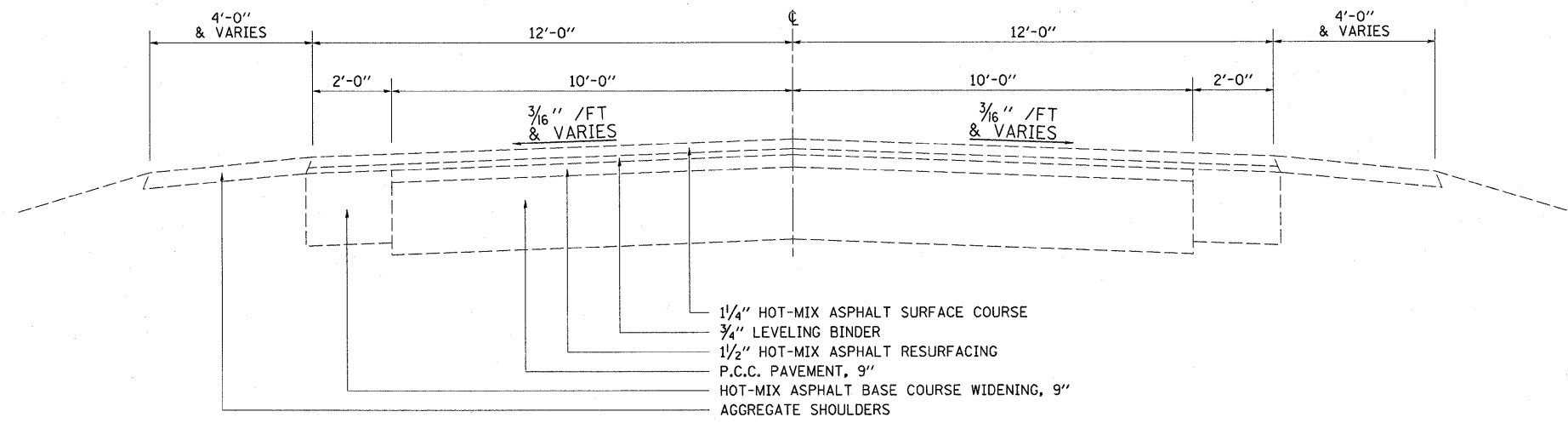

NOTE: NOT DRAWN TO SCALE

FILE NAME =	USER NAME = swartzw	DESIGNED -	REVISED -	STATE OF ILLINOIS DEPARTMENT OF TRANSPORTATION	EXISTING TYPICAL CROSS SECTION			F.A.S. RTE.	SECTION	COUNTY	TOTAL SHEETS	SHEET NO.
o:\p\work\p\dot\swartzw\d0242172\d77	507-shs-typicals.dgn	DRAWN -	REVISED -		677	(15-2,15-1,15,11)RS-1	COLES	63	6			
PLOT SCALE = 20.0000' / IN.	CHECKED -	REVISED -	REVISED -		SCALE: NA			SHEET NO. 2 OF 4 SHEETS		STA.	TO STA.	CONTRACT NO. 74507
PLOT DATE = 1/31/2011	DATE -	REVISED -	REVISED -		ILLINOIS FED. AID PROJECT							

PAVING OMISSION

STATION 349+34.54 TO STATION 351+86.46

EXISTING TYPICAL CROSS SECTION

STATION 334+16.00 TO STATION 349+34.54
STATION 351+86.46 TO STATION 361+10.00

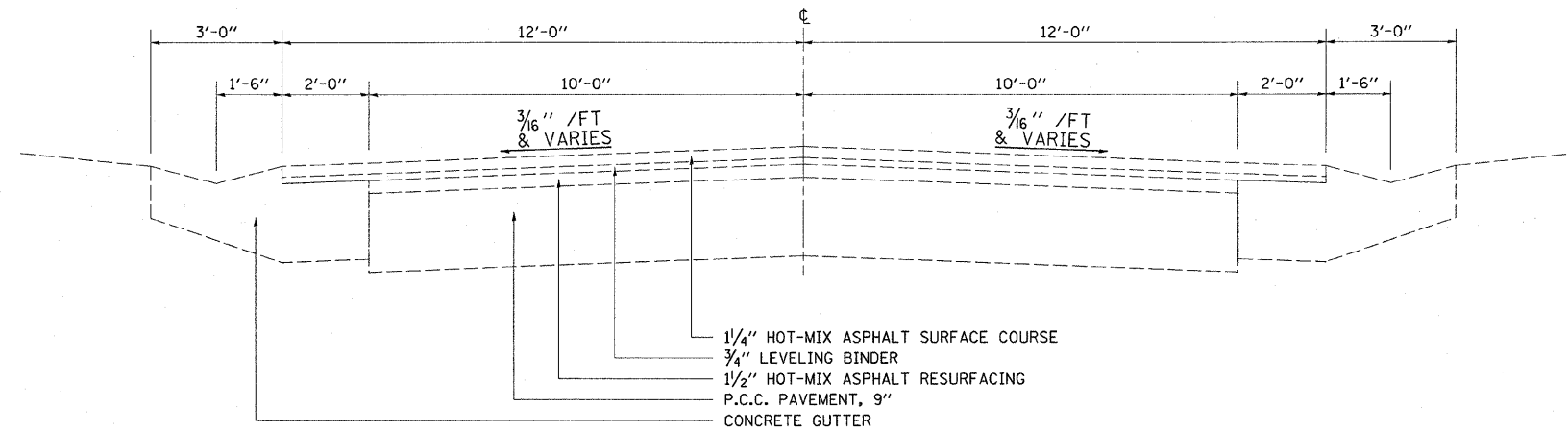

NOTE: NOT DRAWN TO SCALE

PAVING OMISSION

STATION 480+89.50 TO STATION 480+98.60

EXISTING TYPICAL CROSS SECTION

STATION 472+00.00 TO STATION 480+89.50

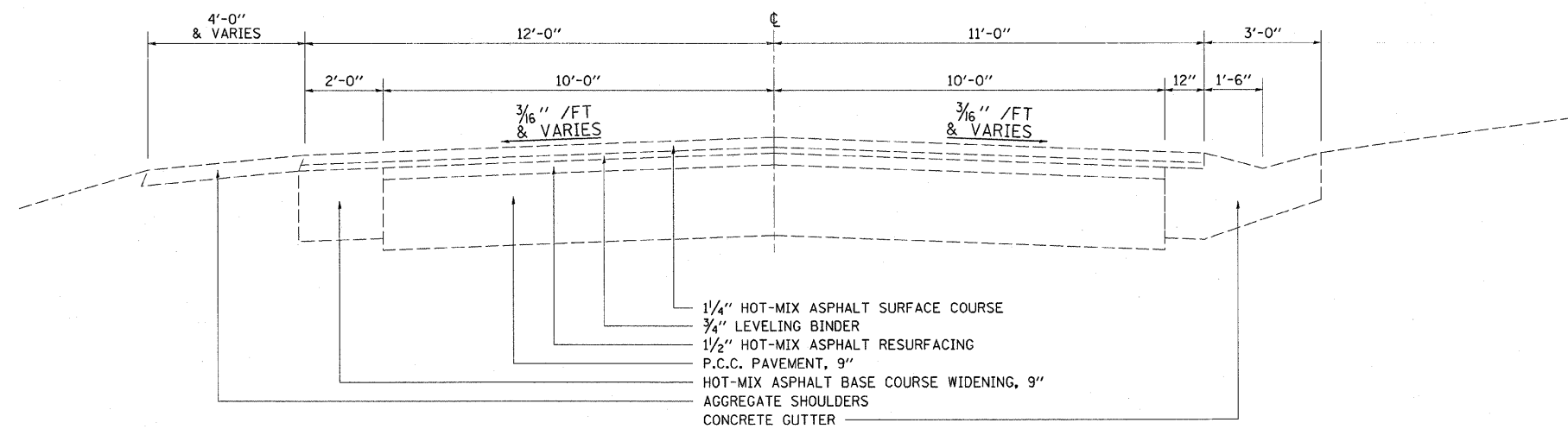

NOTE: NOT DRAWN TO SCALE

FILE NAME =	USER NAME = swartzrw	DESIGNED -	REVISED -	STATE OF ILLINOIS DEPARTMENT OF TRANSPORTATION	EXISTING TYPICAL CROSS SECTION			F.A.S. RTE.	SECTION	COUNTY	TOTAL SHEETS	SHEET NO.	
c:\piv_work\pivdot\swartzrw\0242172\d77	607-shr-typical.dgn	DRAWN -	REVISED -		SCALE: NA	SHEET NO. 3 OF 4 SHEETS	STA.	TO STA.	677	(15-2,15-1,15,11)RS-1	COLES	63	7
PLOT SCALE = 20,0000 ' / IN.	CHECKED -	REVISED -	REVISED -					CONTRACT NO. 74507					
PLOT DATE = 1/31/2011	DATE -	REVISED -	REVISED -					ILLINOIS FED. AID PROJECT					

EXISTING TYPICAL CROSS SECTION

STATION 480+98.60 TO STATION 483+00.00

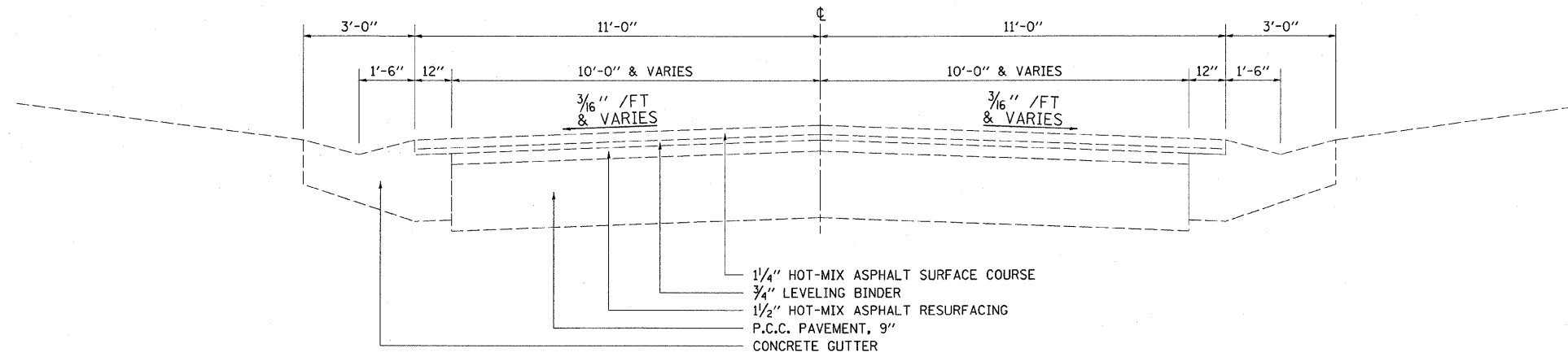

NOTE: NOT DRAWN TO SCALE

EXISTING TYPICAL CROSS SECTION

STATION 483+00.00 TO STATION 483+48.50

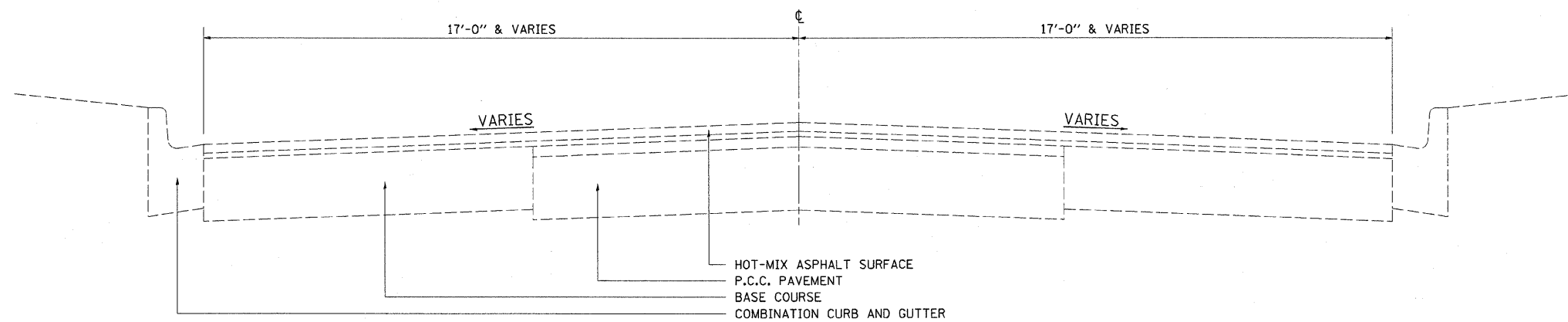

NOTE: NOT DRAWN TO SCALE

FILE NAME =	USER NAME = swartzw	DESIGNED -	REVISED -	STATE OF ILLINOIS DEPARTMENT OF TRANSPORTATION	EXISTING TYPICAL CROSS SECTION			F.A.S. RTE.	SECTION	COUNTY	TOTAL SHEETS	SHEET NO.	
c:\pwwork\pwwork\swartzw\d0242172\d77	507-shr-typical.dgn	DRAWN -	REVISED -		SCALE: NA	SHEET NO. 4 OF 4 SHEETS	STA.	TO STA.	677	(15-2,15-1,15,11)RS-1	COLES	63	8
	PLOT SCALE = 20.0000' / IN.	CHECKED -	REVISED -								CONTRACT NO. 74507		
	PLOT DATE = 1/31/2011	DATE -	REVISED -								ILLINOIS FED. AID PROJECT		

PROPOSED TYPICAL CROSS SECTION

STATION 50+04.50 TO STATION 57+57.10

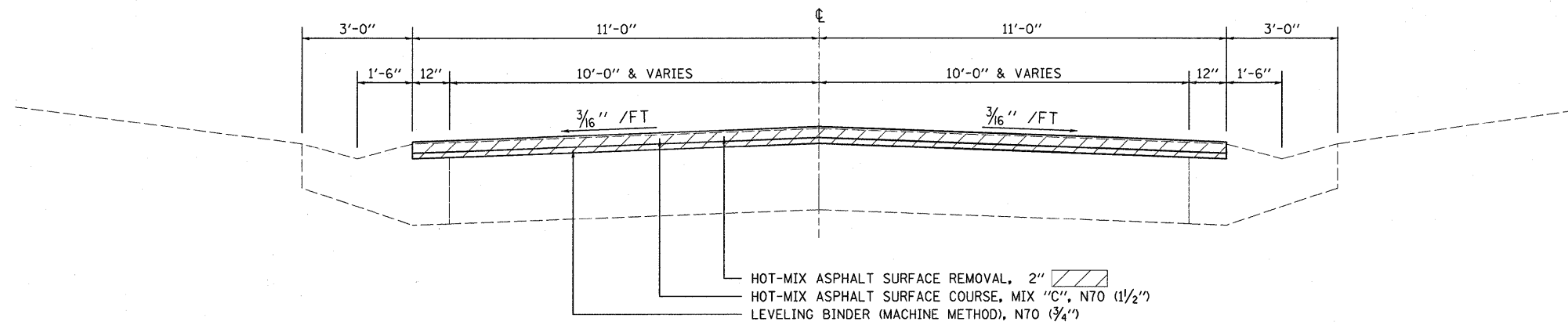

NOTE: NOT DRAWN TO SCALE

PROPOSED TYPICAL CROSS SECTION

STATION 57+57.10 TO STATION 74+62.22

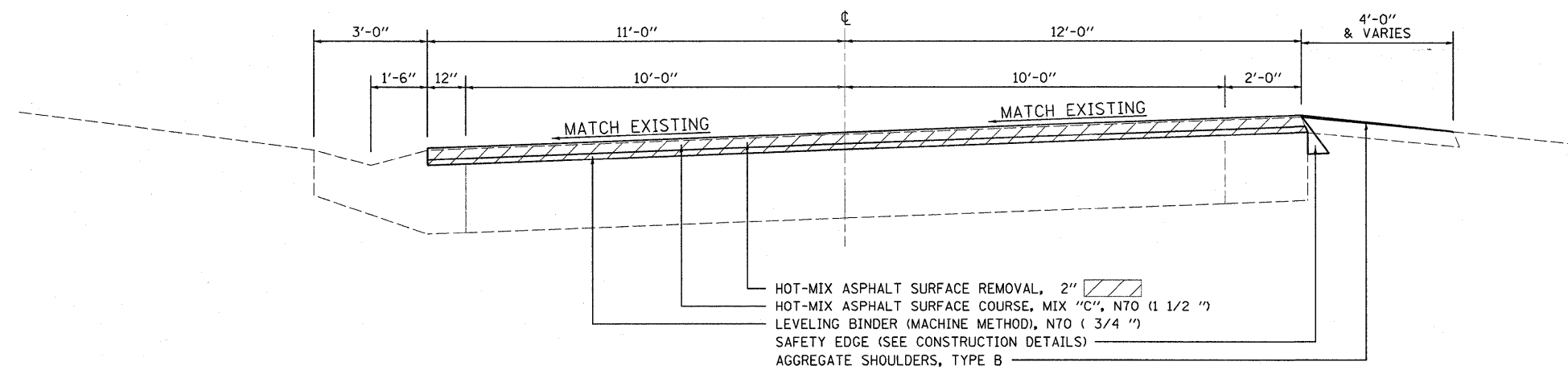

NOTE: NOT DRAWN TO SCALE

FILE NAME =	USER NAME = swartzrw	DESIGNED -	REVISED -	STATE OF ILLINOIS DEPARTMENT OF TRANSPORTATION	PROPOSED TYPICAL CROSS SECTION			F.A.S. RTE.	SECTION	COUNTY	TOTAL SHEETS	SHEET NO.
ca:\pwork\pwork\swartzrw\d0242172\d77	587-shr-typicals.dgn	DRAWN -	REVISED -		677	(15-2,15-1,15,11)RS-1	COLES	63	9			
PLOT SCALE = 20,0000 ' / IN.	CHECKED -	REVISED -	REVISED -		SCALE: NA SHEET NO. 1 OF 4 SHEETS STA. TO STA.			CONTRACT NO. 74507				
PLOT DATE = 1/31/2011	DATE -	REVISED -	REVISED -		ILLINOIS FED. AID PROJECT							

CONCRETE GUTTER DETAIL

STATION 366+53.00 LT TO STATION 368+26.00 LT

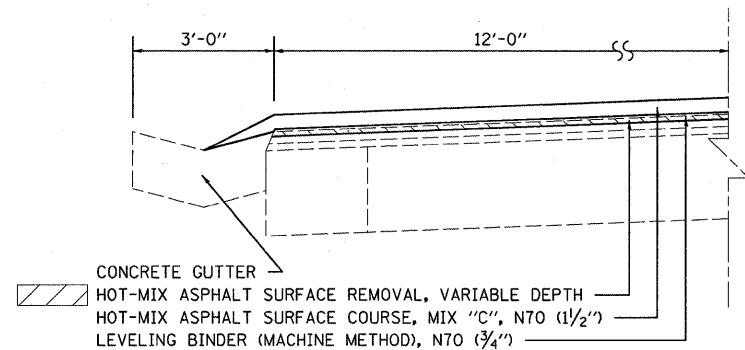

PROPOSED TYPICAL CROSS SECTION

STATION 74+62.22 TO STATION 211+34.00
 STATION 213+86.00 TO STATION 320+91.00
 STATION 364+27.00 TO STATION 416+60.00

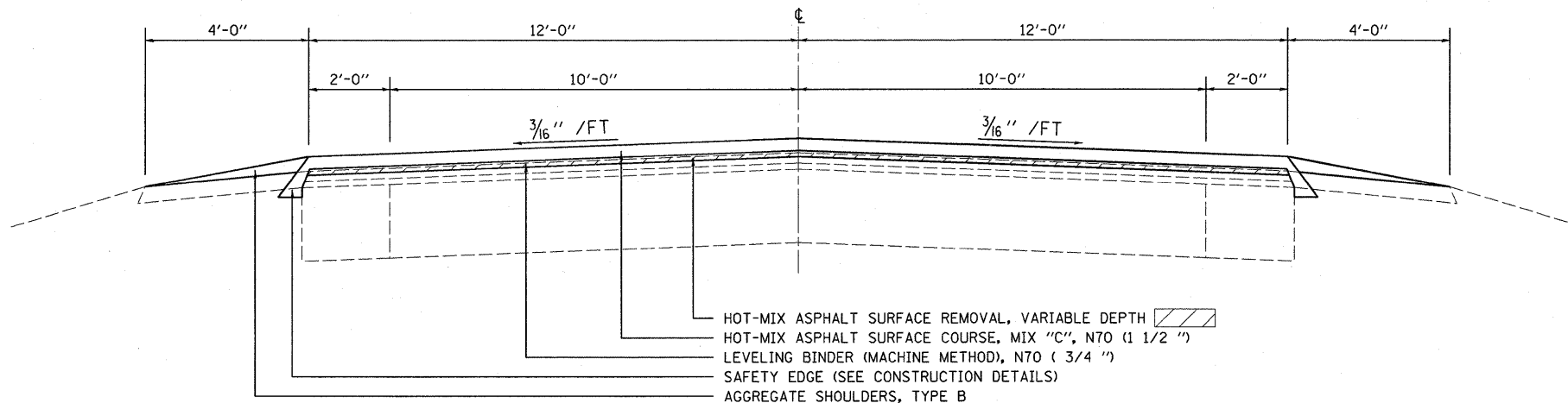

NOTE: NOT DRAWN TO SCALE

PROPOSED TYPICAL CROSS SECTION

STATION 211+34.00 TO STATION 213+86.00
 STATION 320+91.00 TO STATION 334+16.00
 STATION 361+10.00 TO STATION 364+27.00
 STATION 416+60.00 TO STATION 472+00.00

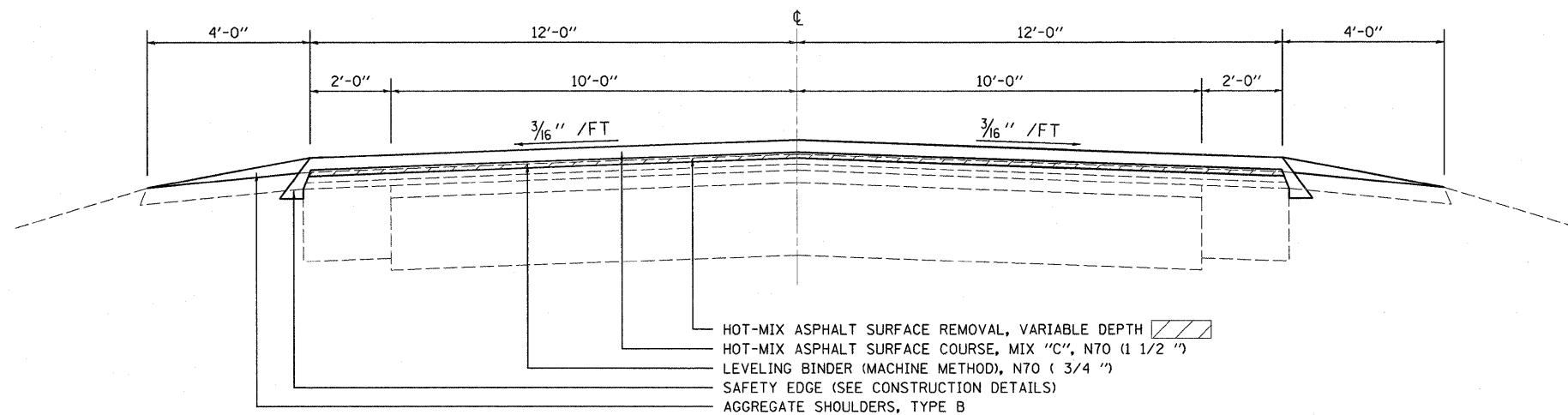

NOTE: NOT DRAWN TO SCALE

FILE NAME =	USER NAME = swartzrw	DESIGNED -	REVISED -	STATE OF ILLINOIS DEPARTMENT OF TRANSPORTATION	PROPOSED TYPICAL CROSS SECTION			F.A.S. RTE.	SECTION	COUNTY	TOTAL SHEETS	SHEET NO.
ca:\pwork\work\swartzrw\0242172\d77	507-shr-typrools.dgn	DRAWN -	REVISED -		677	(15-2,15-1,15,11)RS-1	COLES	63	10			
PLOT SCALE = 20.0000 ' / IN.	CHECKED -	REVISED -	REVISED -		SCALE: NA SHEET NO. 2 OF 4 SHEETS STA. TO STA.			CONTRACT NO. 74507				
PLOT DATE = 1/31/2011	DATE -	REVISED -	REVISED -		ILLINOIS FED. AID PROJECT							

PAVING OMISSION

STATION 349+34.54 TO STATION 351+86.46

PROPOSED TYPICAL CROSS SECTION

STATION 334+16.00 TO STATION 349+34.54
STATION 351+86.46 TO STATION 361+10.00

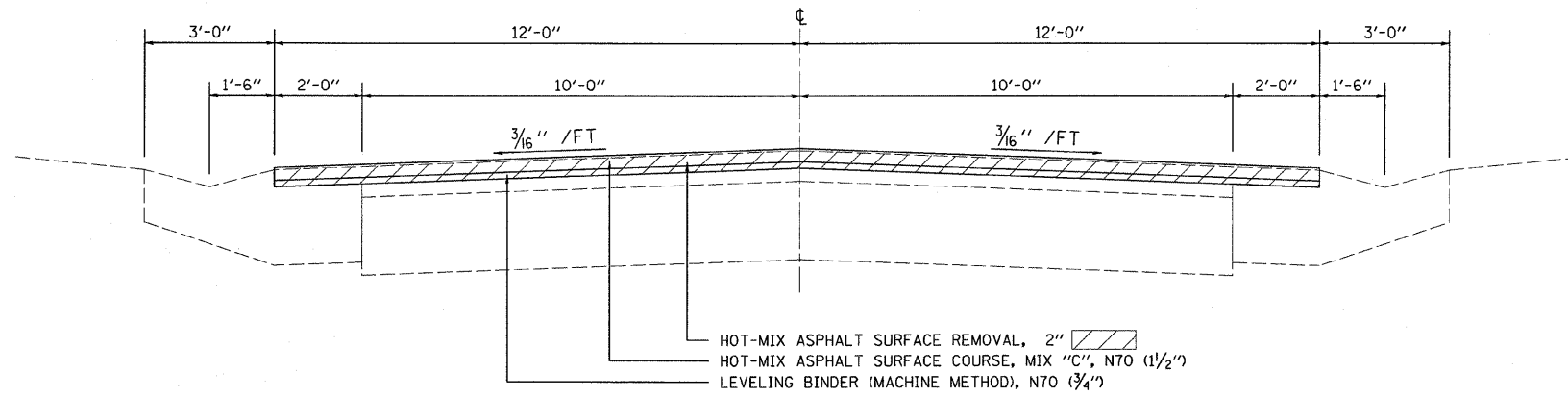

NOTE: NOT DRAWN TO SCALE

PAVING OMISSION

STATION 480+89.50 TO STATION 480+98.60

PROPOSED TYPICAL CROSS SECTION

STATION 472+00.00 TO STATION 480+89.50

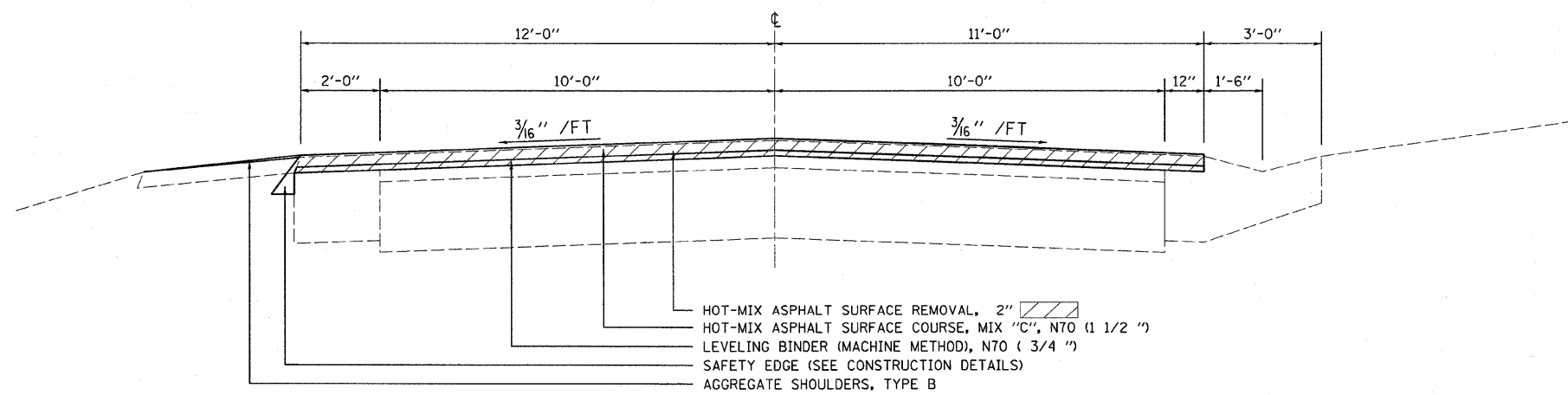

NOTE: NOT DRAWN TO SCALE

FILE NAME =	USER NAME = swartzw	DESIGNED -	REVISED -	STATE OF ILLINOIS DEPARTMENT OF TRANSPORTATION	PROPOSED TYPICAL CROSS SECTION			F.A.S. RTE.	SECTION	COUNTY	TOTAL SHEETS	SHEET NO.
c:\pw_work\pwidot\swartzw\d8242172\d77	507-shr-typicals.dgn	DRAWN -	REVISED -		677	(15-2,15-1,15,11)RS-1	COLES	63	11			
PLOT SCALE = 20.0000' / IN.	CHECKED -	REVISED -	SCALE: NA		SHEET NO. 3 OF 4 SHEETS	STA.	TO STA.	CONTRACT NO. 74507				
PLOT DATE = 1/31/2011	DATE -	REVISED -	ILLINOIS FED. AID PROJECT									

PROPOSED TYPICAL CROSS SECTION

STATION 480+98.60 TO STATION 483+00.00

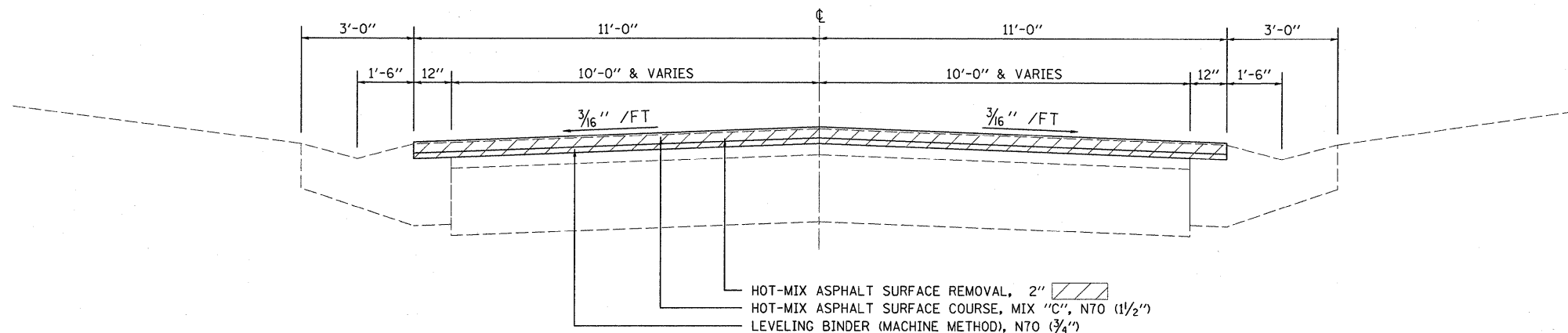

NOTE: NOT DRAWN TO SCALE

PROPOSED TYPICAL CROSS SECTION

STATION 483+00.00 TO STATION 483+48.50

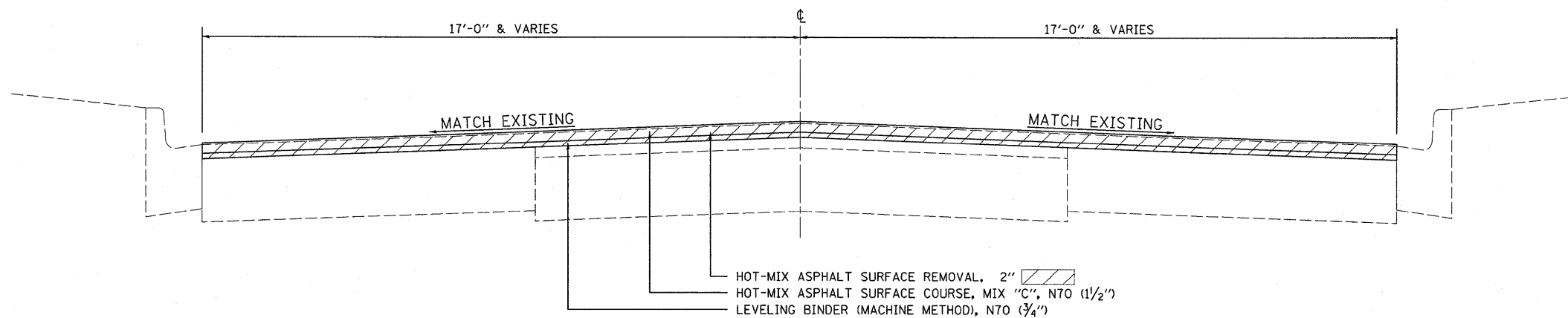

NOTE: NOT DRAWN TO SCALE

FILE NAME =	USER NAME = swartzw	DESIGNED -	REVISED -	STATE OF ILLINOIS DEPARTMENT OF TRANSPORTATION	PROPOSED TYPICAL CROSS SECTION			F.A.S. RTE.	SECTION	COUNTY	TOTAL SHEETS	SHEET NO.
ca:\pw\work\p\dot\swartzw\d0242172\d77	507-shr-typicals.dgn	DRAWN -	REVISED -		677	(15-2,15-1,15,11)RS-1	COLES	63	12			
PLOT SCALE = 20.0000' / IN.	CHECKED -	REVISED -	REVISED -		CONTRACT NO. 74507			ILLINOIS FED. AID PROJECT				
PLOT DATE = 1/31/2011	DATE -	REVISED -	REVISED -		SCALE: NA	SHEET NO. 4 OF 4 SHEETS	STA.	TO STA.				

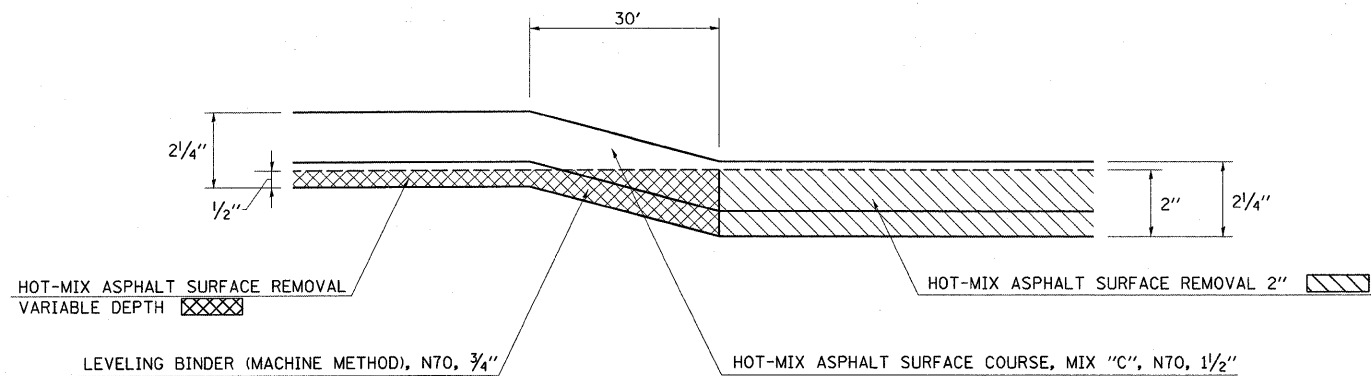

MILLING TRANSITION DETAIL

STA. 61+80.00 TO STA. 62+10.00
 STA. 333+86.00 TO STA. 334+16.00
 STA. 361+10.00 TO STA. 361+40.00
 STA. 471+70.00 TO STA. 472+00.00

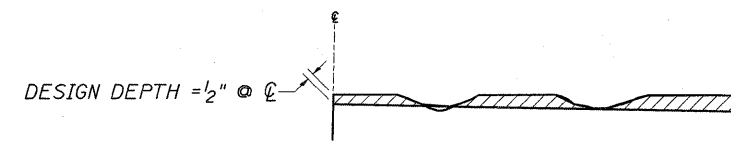

NOTES:

1. MILLING SHALL BE DONE TO ATTAIN A 3/16 "/li>

HOT-MIX ASPHALT SURFACE REMOVAL (VARIABLE DEPTH) DETAIL

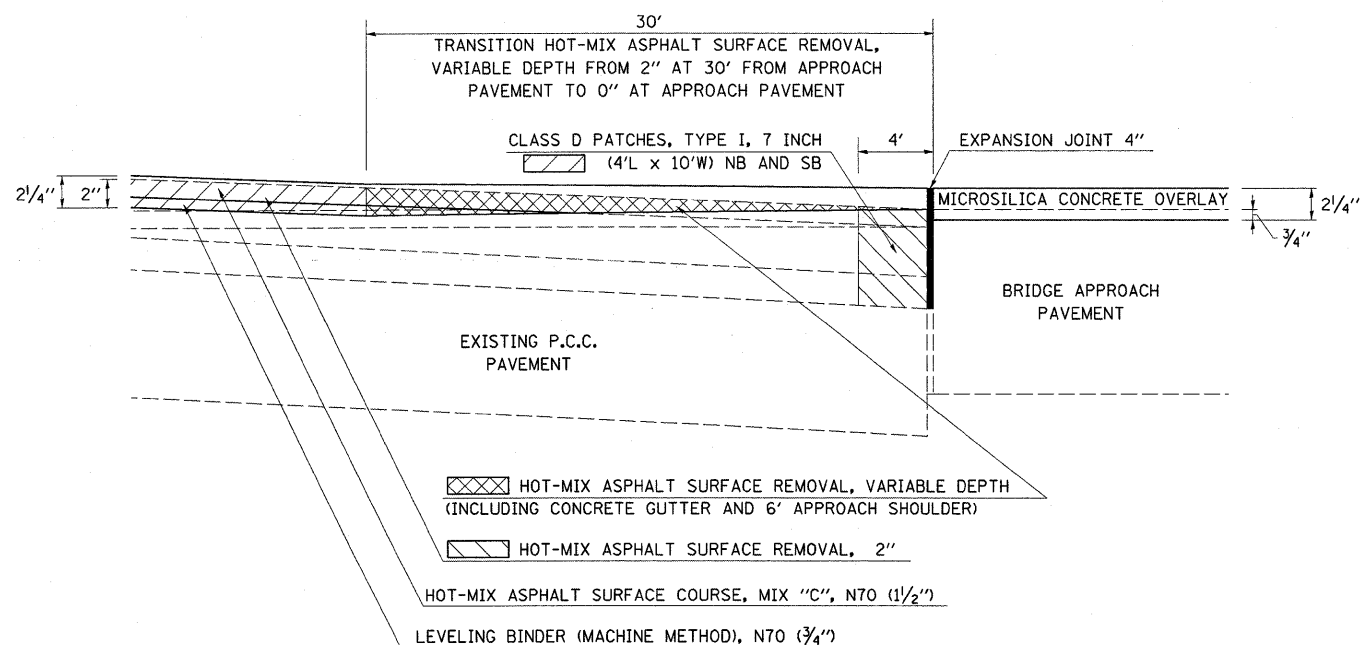

HOT-MIX ASPHALT SURFACE TRANSITION AT SOUTH APPROACH PAVEMENT DETAIL

STATION 349+04.54 TO STATION 349+34.54

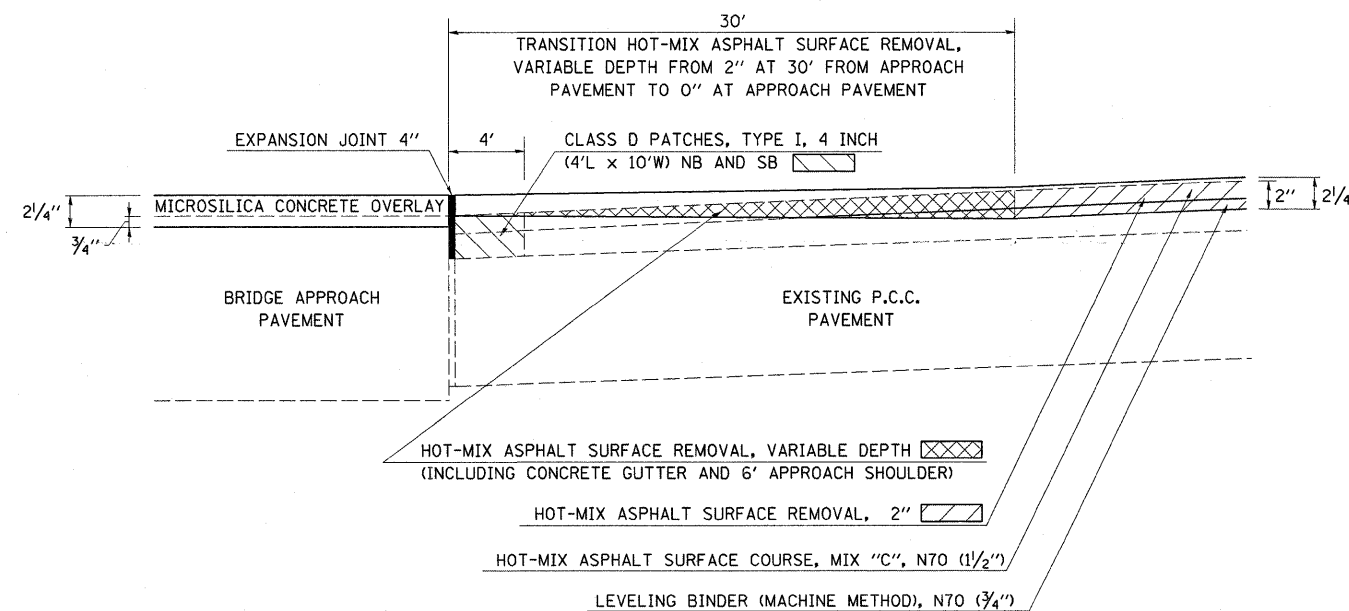

HOT-MIX ASPHALT SURFACE TRANSITION AT NORTH APPROACH PAVEMENT DETAIL

STATION 351+86.46 TO STATION 352+16.46

FILE NAME =	USER NAME = swartzrw	DESIGNED -	REVISED -
c:\pwork\pwork\swartzrw\d0242172\d774507-sht-details.dgn		DRAWN -	REVISED -
PLOT SCALE = 20.0000 "/td> <td></td> <td>CHECKED -</td> <td>REVISED -</td>		CHECKED -	REVISED -
PLOT DATE = 1/31/2011		DATE -	REVISED -

**STATE OF ILLINOIS
 DEPARTMENT OF TRANSPORTATION**

CONSTRUCTION DETAILS

SCALE: NA SHEET NO. 1 OF 2 SHEETS STA. TO STA.

F.A.S RTE.	SECTION	COUNTY	TOTAL SHEETS	SHEET NO.
677	(15-2,15-1,15,11)RS-1	COLES	63	13
FED. ROAD DIST. NO. ILLINOIS FED. AID PROJECT			CONTRACT NO. 74507	

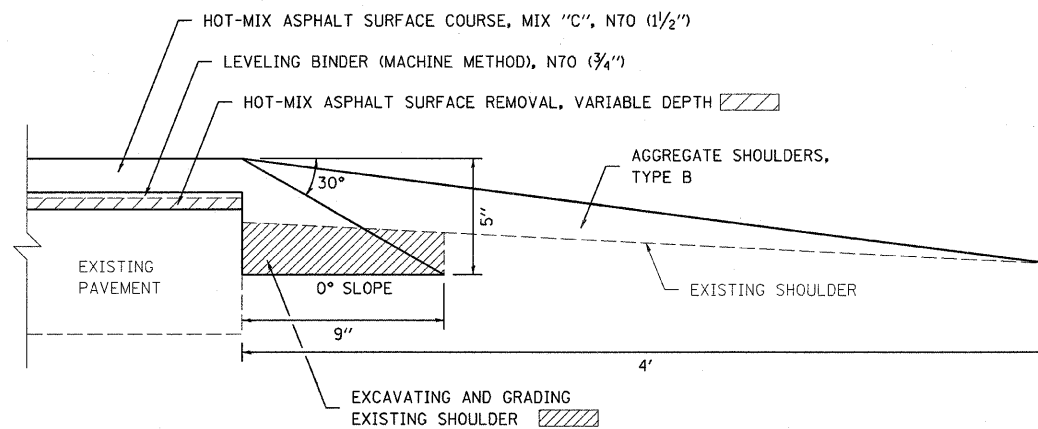

SAFETY EDGE FOR 3P RESURFACING

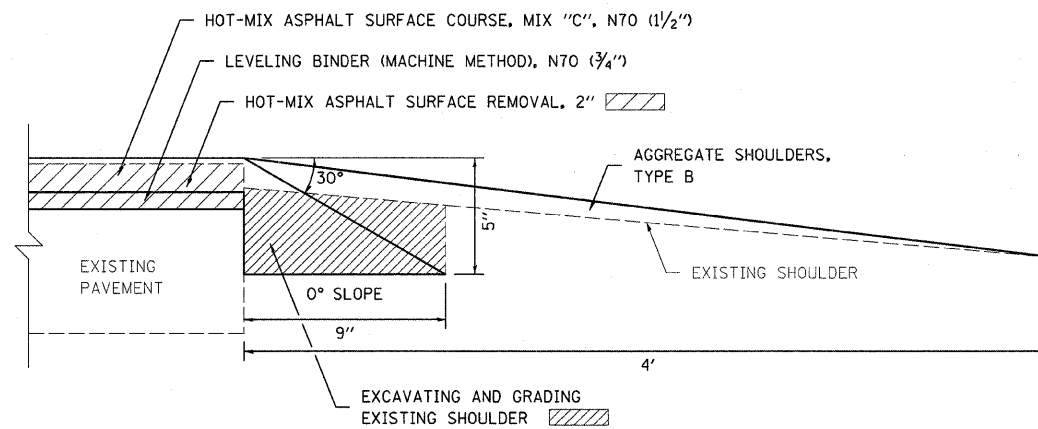

SAFETY EDGE FOR INLAY AREAS

FILE NAME =	USER NAME = swartzw	DESIGNED -	REVISED -	STATE OF ILLINOIS DEPARTMENT OF TRANSPORTATION	CONSTRUCTION DETAILS			F.A.S RTE.	SECTION	COUNTY	TOTAL SHEETS	SHEET NO.
c:\piv_work\piv\dot\swartzw\0242172\d77	607-sht-details.dgn	DRAWN -	REVISED -					677	(15-2,15-1,15,11)RS-1	COLES	63	14
	PLOT SCALE = 20,0000 / / IN.	CHECKED -	REVISED -		SCALE: NA SHEET NO. 2 OF 2 SHEETS STA. TO STA.			CONTRACT NO. 74507				
	PLOT DATE = 1/31/2011	DATE -	REVISED -		FED. ROAD DIST. NO. ILLINOIS FED. AID PROJECT							

RESURFACING SCHEDULE			LENGTH	AVERAGE PAVEMENT WIDTH	AREA	HOT-MIX ASPHALT SURFACE REMOVAL, VARIABLE DEPTH	HOT-MIX ASPHALT SURFACE REMOVAL, 1 1/2 "	HOT-MIX ASPHALT SURFACE REMOVAL, 2 "	BITUMINOUS MATERIALS (PRIME COAT)	AGGREGATE (PRIME COAT)	HOT-MIX ASPHALT SURFACE COURSE, MIX "C", N70	LEVELING BINDER (MACHINE METHOD), N70	EXCAVATING AND GRADING EXISTING SHOULDER	AGGREGATE SHOULDERS, TYPE B	TEMPORARY RAMP	TEMPORARY RAMP, SPECIAL
STATION	TO	STATION														
			FOOT	FOOT	SQ FT	SQ YD	SQ YD	SQ YD	GALLON	TON	TON	TON	UNIT	TON	SQ YD	SQ YD
50+04.50	TO	50+46.50	42.0	VAR	1596.6	0.0	0.0	177.4	35.4	0.4	14.9	7.5	0.0	0.0	50.6	5.0
50+46.50	TO	59+42.00	895.5	22.0	19701.0	0.0	0.0	2189.0	437.8	4.4	183.9	91.9	0.0	0.0	0.0	22.7
59+42.00	TO	60+30.00	88.0	23.0	2024.0	0.0	0.0	224.9	45.0	0.4	18.9	9.4	0.0	0.0	0.0	2.8
60+30.00	TO	61+80.00	150.0	24.0	3600.0	0.0	0.0	400.0	80.0	0.8	35.3	16.8	1.5	2.4	0.0	0.0
61+80.00	TO	62+10.00	30.0	24.0	720.0	80.0	0.0	0.0	16.0	0.2	7.4	3.4	0.6	1.5	0.0	0.0
62+10.00	TO	333+86.00	27176.0	24.0	652224.0	72469.3	0.0	0.0	14493.8	144.9	6701.4	3043.7	526.3	1832.4	0.0	0.0
333+86.00	TO	334+16.00	30.0	24.0	720.0	80.0	0.0	0.0	16.0	0.2	7.4	3.4	0.6	1.5	0.0	0.0
334+16.00	TO	349+04.54	1488.5	24.0	35725.0	0.0	0.0	3969.4	793.8	7.9	333.4	166.7	0.0	0.0	0.0	4.4
349+04.54	TO	349+34.54	30.0	VAR	912.3	101.4	0.0	0.0	20.2	0.2	8.5	0.8	0.0	0.0	17.2	0.0
349+34.54	TO	351+86.46	251.9	0.0	0.0	0.0	0.0	0.0	0.0	0.0	0.0	0.0	0.0	0.0	0.0	0.0
351+86.46	TO	352+16.46	30.0	VAR	911.8	101.3	0.0	0.0	20.2	0.2	8.5	0.8	0.0	0.0	17.2	0.0
352+16.46	TO	361+10.00	893.5	24.0	21445.0	0.0	0.0	2382.8	476.6	4.8	200.2	100.1	0.0	0.0	0.0	5.6
361+10.00	TO	361+40.00	30.0	24.0	720.0	80.0	0.0	0.0	16.0	0.2	7.0	3.4	0.3	0.8	0.0	0.0
361+40.00	TO	366+53.00	513.0	24.0	12312.0	1368.0	0.0	0.0	273.6	2.7	125.7	57.5	9.2	32.2	0.0	0.0
366+53.00	TO	368+26.00	173.0	24.0	4152.0	461.3	0.0	0.0	92.2	0.9	41.2	19.4	1.0	3.5	0.0	0.0
368+26.00	TO	471+70.00	10344.0	24.0	248256.0	27584.0	0.0	0.0	5516.8	55.2	2552.5	1158.5	201.8	704.7	0.0	0.0
471+70.00	TO	472+00.00	30.0	24.0	720.0	80.0	0.0	0.0	16.0	0.2	7.4	3.4	0.6	1.5	0.0	0.0
472+00.00	TO	480+89.50	889.5	23.0	20458.5	0.0	0.0	2273.2	454.6	4.5	200.7	95.5	8.4	13.3	21.8	18.3
480+89.50	TO	480+98.60	9.1	0.0	0.0	0.0	0.0	0.0	0.0	0.0	0.0	0.0	0.0	0.0	0.0	0.0
480+98.60	TO	482+87.50	188.9	22.0	4155.8	0.0	0.0	461.8	92.4	0.9	38.8	19.4	0.0	0.0	21.0	0.0
482+87.50	TO	483+48.50	61.0	VAR	1807.6	0.0	0.0	200.8	40.2	0.4	16.9	8.4	0.0	0.0	18.7	0.0
SIDEROAD/WIDENED SHOULDER AREA																
59+42.00	TO	61+79.26	237.3	VAR	4254.9	0.0	472.8	0.0	94.6	0.9	39.7	0.0	0.0	0.0	0.0	3.3
TOTALS						102406.0	473.0	12280.0	23032.0	231.0	10550.0	4810.0	751.0	2594.0	147.0	63.0

FILE NAME =	USER NAME = swartzr	DESIGNED -	REVISED -	STATE OF ILLINOIS DEPARTMENT OF TRANSPORTATION	SCHEDULE OF QUANTITIES			F.A.S. RTE.	SECTION	COUNTY	TOTAL SHEETS	SHEET NO.
os:\pw_work\pwidot\swartzr\id8242172\d77	687-sht-sch.dgn	DRAWN -	REVISED -		677	(15-2,15-1,15,11)RS-1	COLES	63	15			
PLOT SCALE = 50,0000 "/ IN.	CHECKED -	REVISED -	SCALE: NA		SHEET NO. 1	OF 2 SHEETS	STA.	TO STA.	CONTRACT NO. 74507			
PLOT DATE = 1/31/2011	DATE -	REVISED -	ILLINOIS FED. AID PROJECT									

PAVEMENT MARKING SCHEDULE	LENGTH	PAINT PAVEMENT MARKING - LINE 4" WHITE	PAINT PAVEMENT MARKING - LINE 4" YELLOW	THERMOPLASTIC PAVEMENT MARKING - LINE 24"	THERMOPLASTIC PAVEMENT MARKING - LETTERS AND SYMBOLS	TEMPORARY PAVEMENT MARKING - LINE 4"	TEMPORARY PAVEMENT MARKING - LINE 24"	TEMPORARY PAVEMENT MARKING - LETTERS & SYMBOLS	SHORT-TERM PAVEMENT MARKING	WORK ZONE PAVEMENT MARKING REMOVAL	RAISED REFLECTIVE PAVEMENT MARKER
50+04.50 TO 50+46.50	42.0	0.0	10.5	0.0	0.0	10.5	0.0	0.0	16.0	1.3	1.0
50+46.50 TO 57+56.00	709.5	1282.0	177.4	0.0	0.0	1459.4	0.0	0.0	288.0	24.0	9.0
57+56.00 TO 68+60.00	1104.0	2040.0	1380.0	0.0	0.0	3420.0	0.0	0.0	448.0	37.3	14.0
68+60.00 TO 83+89.00	1529.0	3015.0	1911.3	0.0	0.0	4926.3	0.0	0.0	608.0	50.7	19.0
83+89.00 TO 336+90.00	25301.0	49835.0	6325.3	0.0	0.0	56160.3	0.0	0.0	10128.0	844.0	316.0
336+90.00 TO 342+89.00	599.0	1198.0	748.8	0.0	0.0	1946.8	0.0	0.0	240.0	20.0	7.0
342+89.00 TO 345+19.00	230.0	460.0	287.5	0.0	0.0	747.5	0.0	0.0	96.0	8.0	3.0
345+19.00 TO 348+79.00	360.0	720.0	720.0	0.0	0.0	1440.0	0.0	0.0	144.0	12.0	5.0
348+79.00 TO 349+34.54	55.5	111.1	69.4	0.0	0.0	180.5	0.0	0.0	16.0	1.3	1.0
349+34.54 TO 351+86.46	251.9	503.8	314.9	0.0	0.0	818.7	0.0	0.0	0.0	0.0	0.0
351+86.46 TO 361+02.00	915.5	1831.1	1144.4	0.0	0.0	2975.5	0.0	0.0	368.0	30.7	11.0
361+02.00 TO 371+96.00	1094.0	2188.0	1367.5	0.0	0.0	3555.5	0.0	0.0	432.0	36.0	14.0
371+96.00 TO 476+89.00	10493.0	20839.0	2623.3	0.0	0.0	23462.3	0.0	0.0	4192.0	349.3	131.0
476+89.00 TO 480+89.50	400.5	801.0	500.6	33.0	61.2	1301.6	33.0	61.2	160.0	13.3	5.0
480+89.50 TO 480+98.60	9.1	0.0	0.0	0.0	0.0	0.0	0.0	0.0	0.0	0.0	0.0
480+98.60 TO 483+02.00	203.4	406.8	254.3	33.0	61.2	661.1	33.0	61.2	80.0	6.7	3.0
483+02.00 TO 483+48.50	46.5	0.0	58.1	0.0	0.0	58.1	0.0	0.0	16.0	1.3	1.0
MAINLINE TOTALS		85231.0	17893.0	66.0	123.0	103124.0	66.0	123.0	17232.0	1436.0	540.0

FILE NAME =	USER NAME = swartzw	DESIGNED -	REVISED -
cf:\pwork\pwork\swartzw\d0242172\d77	507-sht-seh.dgn	DRAWN -	REVISED -
	PLOT SCALE = 50.0000 ' / IN.	CHECKED -	REVISED -
	PLOT DATE = 1/31/2011	DATE -	REVISED -

**STATE OF ILLINOIS
DEPARTMENT OF TRANSPORTATION**

SCHEDULE OF QUANTITIES

SCALE: NA SHEET NO. 2 OF 2 SHEETS STA. TO STA.

F.A.S. RTE.	SECTION	COUNTY	TOTAL SHEETS	SHEET NO.
677	(15-2,15-1,15,11)RS-1	COLES	63	16
CONTRACT NO. 74507				
ILLINOIS FED. AID PROJECT				

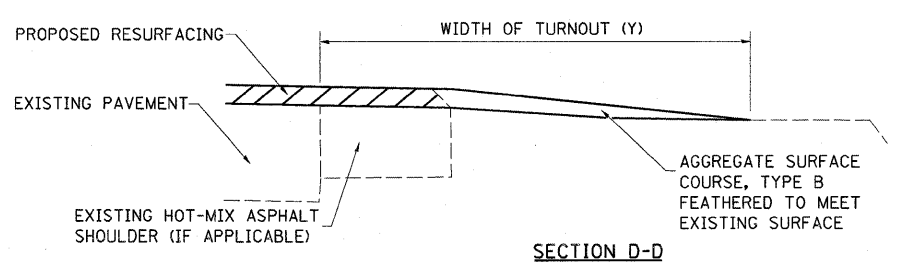
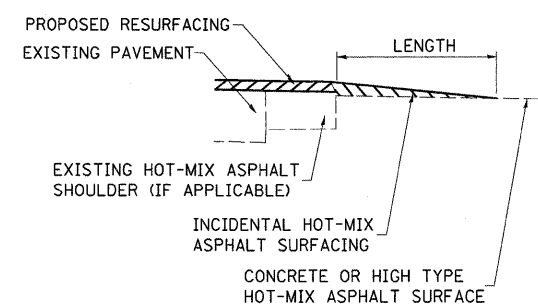
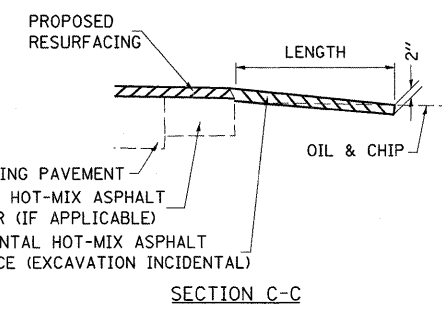
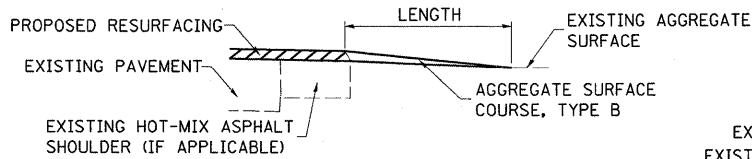
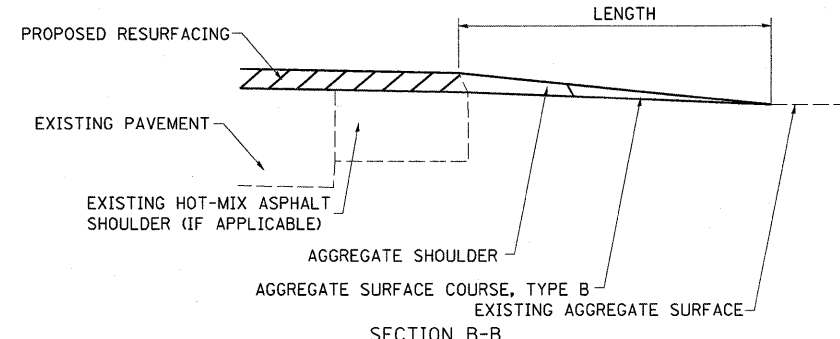
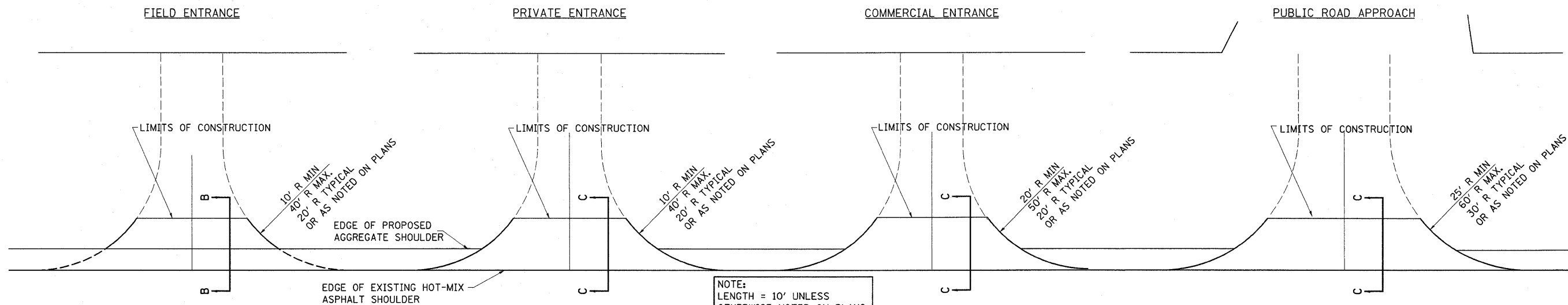

TYPICAL SECTION AT MAILBOX TURNOUT
NOTE: SEE STANDARD 406201 FOR MAILBOX TURNOUT DETAILS

NOTES

THE COST OF THE ASPHALT MATERIALS, AND AGGREGATE (PRIME COAT) FOR ENTRANCES AND PUBLIC ROADS AND APPROACHES SHALL BE INCLUDED IN THE PAY ITEM INCIDENTAL HOT-MIX ASPHALT SURFACING.

THE COST OF EXCAVATION IS INCLUDED IN THE PAY ITEM INCIDENTAL HOT-MIX ASPHALT SURFACING.

IF THERE IS NOT EXISTING HOT-MIX ASPHALT SHOULDER THEN THE ENTRANCE TAPER STARTS AT THE EDGE OF EXISTING PAVEMENT.

THE COST OF THE BITUMINOUS MATERIALS AND AGGREGATE (PRIME COAT) FOR ENTRANCES AND PUBLIC ROAD APPROACHES SHALL BE INCLUDED IN THE PAY ITEM INCIDENTAL HOT-MIX ASPHALT SURFACING.

SIDE	STATION	TYPE	INCIDENTAL HOT-MIX ASPHALT SURFACING	
			TON	TON
LT	63+03.0	CE	2.7	
LT	64+48.0	CE	3.7	
LT	66+49.0	CE		3.2
LT	68+44.0	CE		2.6
RT	68+67.0	PE	1.6	1.1
LT	68+77.0	CE	3.2	
RT	72+01.0	PRA	2.3	
RT	74+75.5	PE	1.8	
LT	76+12.0	FE		1.3
RT	85+84.5	FE		1.6
LT	89+47.0	PRA	4.1	
RT	92+21.0	FE		2.3
RT	93+35.0	MBT1	2.0	
LT	93+59.0	PE	2.8	
RT	100+55.5	FE		1.8
LT	101+43.5	FE		1.9
RT	110+40.0	FE		1.7
LT	110+46.0	FE		1.7
LT	120+96.0	FE		1.6
RT	124+20.5	FE		1.5
LT	128+60.0	FE	1.7	1.0
RT	133+66.0	FE		1.4
LT	141+93.0	FE		1.2
RT	146+53.0	FE		1.4
LT	151+06.5	PRA	4.0	
RT	154+69.5	PRA	3.8	
RT	159+93.0	PE	2.7	

SIDE	STATION	TYPE	INCIDENTAL HOT-MIX ASPHALT SURFACING	
			TON	TON
LT	166+95.0	FE		2.1
LT	170+06.5	PRA	3.0	
LT	171+08.0	MBT2	1.3	
LT	171+57.0	PE	2.5	
RT	178+21.0	FE		1.7
LT	179+06.0	PE	2.0	
LT	181+64.0	PRA	2.1	
LT	182+86.5	PE	2.0	
RT	183+09.0	FE		1.7
RT	191+23.0	FE		1.1
LT	195+01.0	PE	2.5	
LT	196+79.0	PE		1.5
RT	204+09.0	PRA	4.5	
LT	208+00.5	PRA	3.8	
RT	216+64.5	PE	2.8	
RT	216+96.0	MBT2	1.3	
LT	221+30.0	FE		1.3
LT	231+04.0	FE		1.9
LT	231+65.0	FE		1.6
LT	238+53.5	FE		1.3
RT	238+54.5	PE	3.4	
LT	247+01.0	FE		0.9
LT	247+90.5	FE		1.8
RT	257+89.0	PRA	3.5	
LT	260+64.0	FE		2.1
RT	268+84.0	PRA	3.3	
LT	268+94.5	FE		2.2

SIDE	STATION	TYPE	INCIDENTAL HOT-MIX ASPHALT SURFACING	
			TON	TON
LT	274+37.0	PRA	3.8	
LT	282+73.5	FE		2.3
LT	288+12.0	FE		1.7
RT	288+15.0	PE	2.7	
LT	294+07.5	PE		1.8
RT	297+85.5	FE		1.6
LT	298+17.0	FE		1.4
LT	308+24.5	FE	1.9	1.2
RT	313+12.5	PE		1.9
RT	321+91.0	PRA	3.7	
RT	324+26.0	CE		2.3
LT	327+17.5	PRA	3.7	
RT	332+80.0	PE	1.7	1.0
LT	362+48.0	FE	1.9	1.0
RT	363+65.0	PE	3.1	
RT	367+82.0	PE	2.3	
RT	368+09.0	MBT2	1.3	
LT	368+48.0	PE		2.4
LT	369+11.5	FE		1.9
RT	381+42.5	PRA	4.2	
RT	390+05.5	FE		1.5
LT	392+50.5	FE		1.9
RT	396+67.5	FE		1.8
RT	404+48.5	FE		1.7
LT	406+12.0	PRA	4.2	
RT	411+29.0	PE		3.6
RT	411+53.0	PE		

SIDE	STATION	TYPE	INCIDENTAL HOT-MIX ASPHALT SURFACING	
			TON	TON
LT	411+78.0	MBT1	2.0	
RT	417+35.0	FE	1.1	0.7
LT	425+62.0	FE	1.2	0.8
RT	430+64.5	FE		3.4
LT	430+66.0	PE	2.9	
LT	432+00.0	PE	2.8	
LT	438+47.0	FE	1.3	0.9
RT	439+80.0	FE		1.3
RT	444+76.0	FE		1.2
LT	451+72.0	FE		1.6
RT	452+40.5	PE	2.1	
RT	457+19.0	FE		2.3
LT	459+41.0	FE		1.4
LT	476+47.0	CE	2.9	
LT	483+20.5	PRA	3.8	
TOTALS			133.0	90.0

FE=FIELD ENTRANCE PRA - PUBLIC ROAD APPROACH
PE=PRIVATE ENTRANCE MBT - MAILBOX TURNOUT
CE=COMMERCIAL ENTRANCE

FILE NAME =	USER NAME = swartzw	DESIGNED - 08-03-99	REVISED - 03-13-07
es:\pw_work\pwidot\swartzw\d0242172\d77	507-shd-details.dgn	DRAWN -	REVISED -
	PLOT SCALE = 20,000 ' / IN.	CHECKED -	REVISED -
	PLOT DATE = 1/31/2011	DATE -	REVISED -

**STATE OF ILLINOIS
DEPARTMENT OF TRANSPORTATION**

**RURAL ENTRANCE SCHEDULE AND MAILBOX TURNOUT DETAILS
WITH SHOULDERS**

SCALE: NA SHEET NO. 1 OF 1 SHEETS STA. TO STA.

F.A.S. RTE.	SECTION	COUNTY	TOTAL SHEETS	SHEET NO.
677	(15-2,15-1,15,1)RS-1	COLES	63	17
FED. ROAD DIST. NO. ILLINOIS FED. AID PROJECT			CONTRACT NO. 74507	

NE COR SE 1/4 SECT 25-13-10
PK NAIL
STA. 89+45, 3.0' RT.

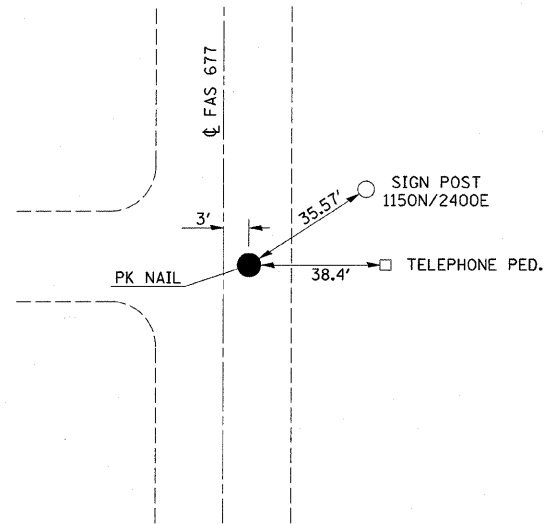

NOTE: NOT DRAWN TO SCALE

NE COR 24-13N-10E
ALUM IDOT VAULT
STA. 168+20, 0.5' RT.

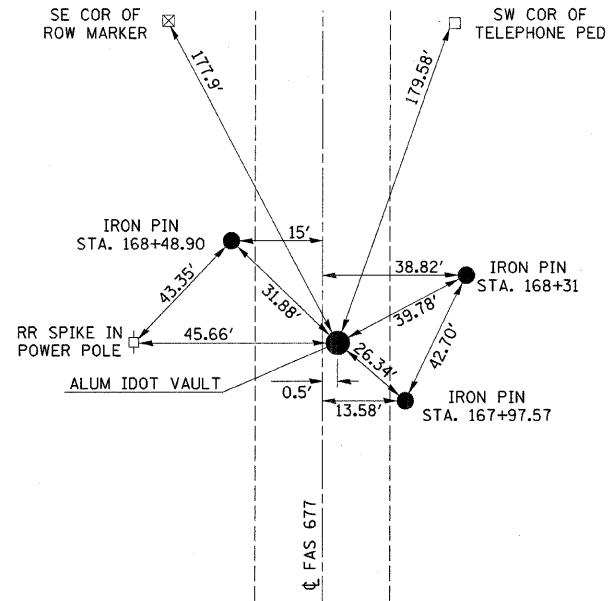

NOTE: NOT DRAWN TO SCALE

E 1/4 COR SECT 13-13-10
ALUM IDOT VAULT
STA. 194+62, 2.2' LT.

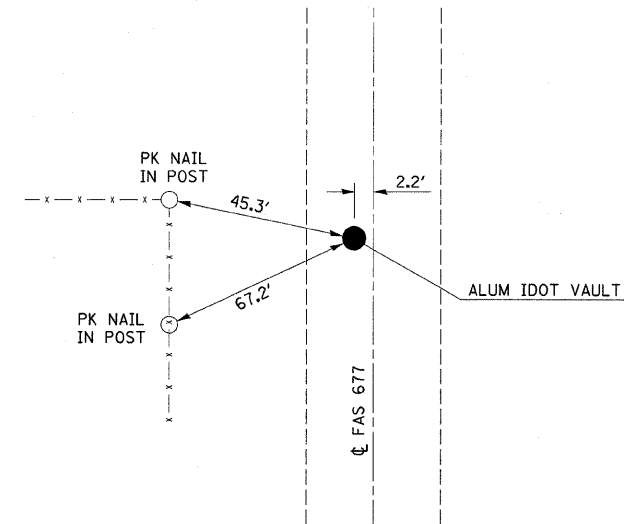

NOTE: NOT DRAWN TO SCALE

SE COR 12-13N-10E
PERMANENT SURVEY
MARKER (VAULT)
STA. 221+19.40, RT. 0.6'

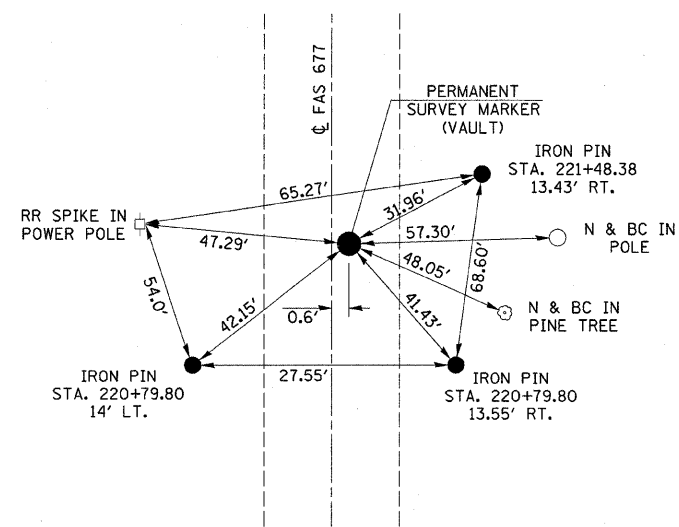

NOTE: NOT DRAWN TO SCALE

SW COR SECT 7-13-11
IRON PIN W/CAP
STA. 231+15, 2.5' RT.

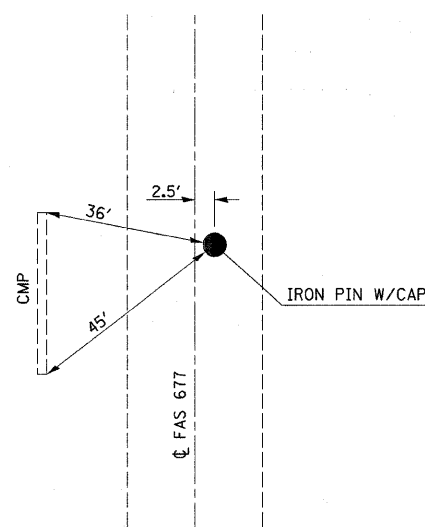

NOTE: NOT DRAWN TO SCALE

E 1/4 COR 12-13N-10E
PERMANENT SURVEY
MARKER (VAULT)
STA. 247+68.8, 5.6' RT.

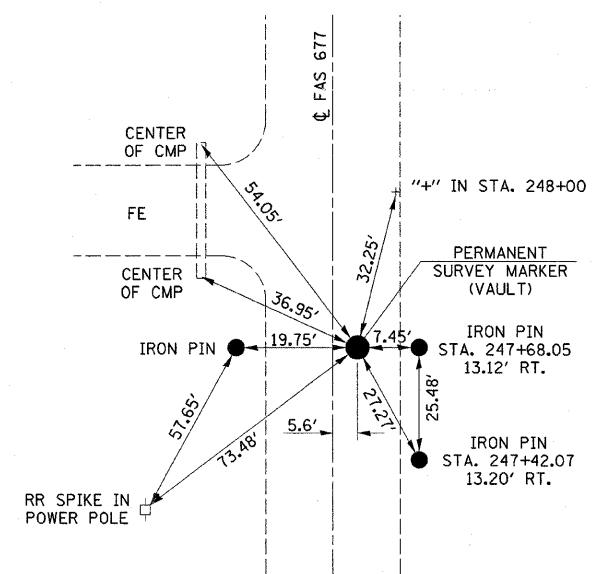

NOTE: NOT DRAWN TO SCALE

FILE NAME =	USER NAME = swartzw	DESIGNED -	REVISED -
c:\pw_work\pvdot\swartzw\d0242172\d77	507-shs-details.dgn	DRAWN -	REVISED -
	PLOT SCALE = 20.0000' / IN.	CHECKED -	REVISED -
	PLOT DATE = 1/31/2011	DATE -	REVISED -

STATE OF ILLINOIS
DEPARTMENT OF TRANSPORTATION

TIE POINTS

SCALE: NA SHEET NO. 1 OF 2 SHEETS STA. TO STA.

F.A.S. RTE.	SECTION	COUNTY	TOTAL SHEETS	SHEET NO.
677	(15-2,15-1,15,11)RS-1	COLES	63	18
FED. ROAD DIST. NO. ILLINOIS FED. AID PROJECT			CONTRACT NO. 74507	

NE COR 12-13N-10E
PERMANENT SURVEY
MARKER (VAULT)
STA. 274+21.20, 4.0' RT.

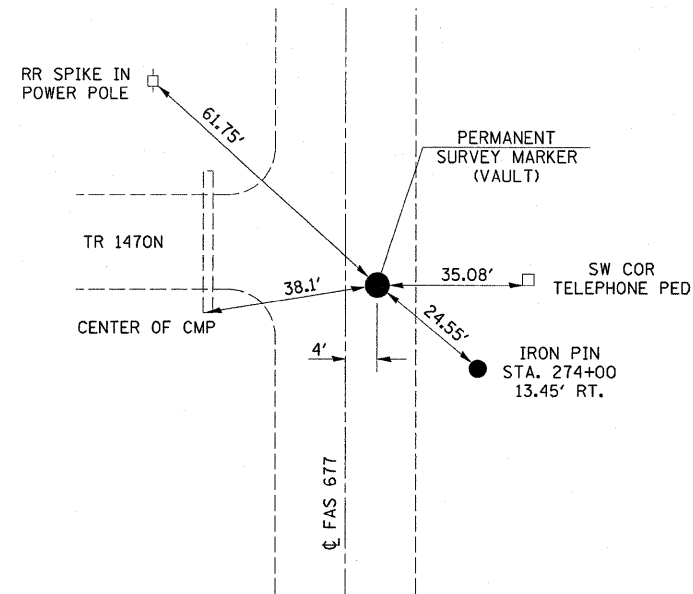

NOTE: NOT DRAWN TO SCALE

SE COR NE 1/4 SECT 36-14-10
PK NAIL
STA. 353+46, 8.0' RT.

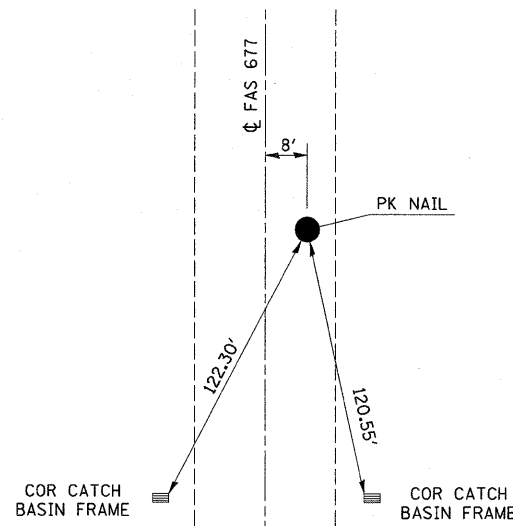

NOTE: NOT DRAWN TO SCALE

NE COR SECT 36-14-10
PK NAIL
STA. 379+75, 4.4' LT.

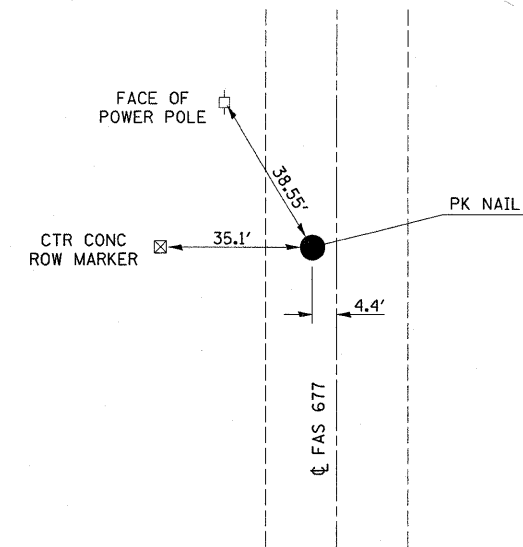

NOTE: NOT DRAWN TO SCALE

NW COR SECT 31-14-11
PK NAIL
STA. 390+20, 10.5' LT.

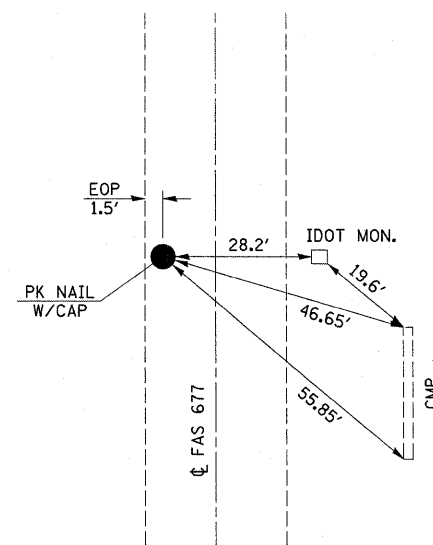

NOTE: NOT DRAWN TO SCALE

E 1/4 COR SECT 25-14-10
PK NAIL W/CAP
STA. 406+28, 17.5' LT.

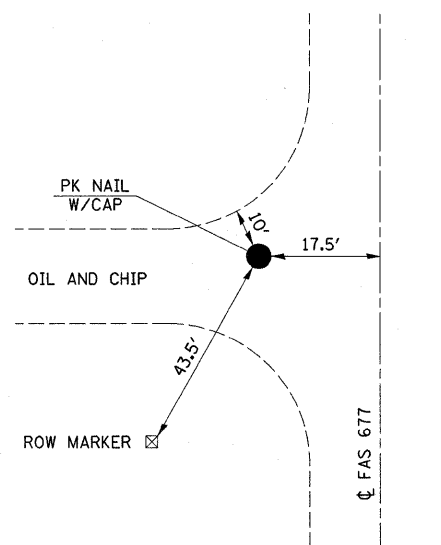

NOTE: NOT DRAWN TO SCALE

SURVEY MARKER SCHEDULE	SURVEY MARKER VAULT	SURVEY MONUMENT COVER ASSEMBLY
LOCATION	EACH	EACH
89+45, 3.0' RT	1.0	
168+20, 0.5' RT		1.0
194+62, 2.2' LT		1.0
221+19.4, 0.6' RT		1.0
231+15, 2.5' RT	1.0	
247+68.8, 5.6' RT		1.0
274+21.2, 4.0' RT		1.0
353+46, 8.0' RT	1.0	
379+75, 4.4' LT	1.0	
390+20, 10.5' LT	1.0	
406+28, 17.5' LT	1.0	
TOTAL	6.0	5.0

FILE NAME =	USER NAME = swartzrw	DESIGNED -	REVISED -
ct:\pw_work\pwidot\swartzrw\d0242172\d77	507-shr-details.dgn	DRAWN -	REVISED -
	PLOT SCALE = 20.0000' / IN.	CHECKED -	REVISED -
	PLOT DATE = 1/31/2011	DATE -	REVISED -

STATE OF ILLINOIS
DEPARTMENT OF TRANSPORTATION

TIE POINTS

SCALE: NA SHEET NO. 2 OF 2 SHEETS STA. TO STA.

F.A.S. RTE.	SECTION	COUNTY	TOTAL SHEETS	SHEET NO.
677	(15-2,15-1,15,11)RS-1	COLES	63	19
FED. ROAD DIST. NO. ILLINOIS FED. AID PROJECT			CONTRACT NO. 74507	

EXIST. CURVE CUR1
 PI STA. = 60+26.62
 $\Delta = 11^\circ 45' 31''$ (LT)
 $D = 2^\circ 56' 48''$
 $R = 1,944.36'$
 $T = 200.22'$
 $L = 399.03'$
 $E = 10.28'$
 $e =$ -----
 $T.R. =$ -----
 $S.E. RUN =$ -----
 $P.C. STA. = 58+26.40$
 $P.T. STA. = 62+25.43$

FAS ROUTE 677
 SECTION (15-2, 15-1, 15, 11) RS-1
 COLES COUNTY
 BEGINS STATION 50+04.50

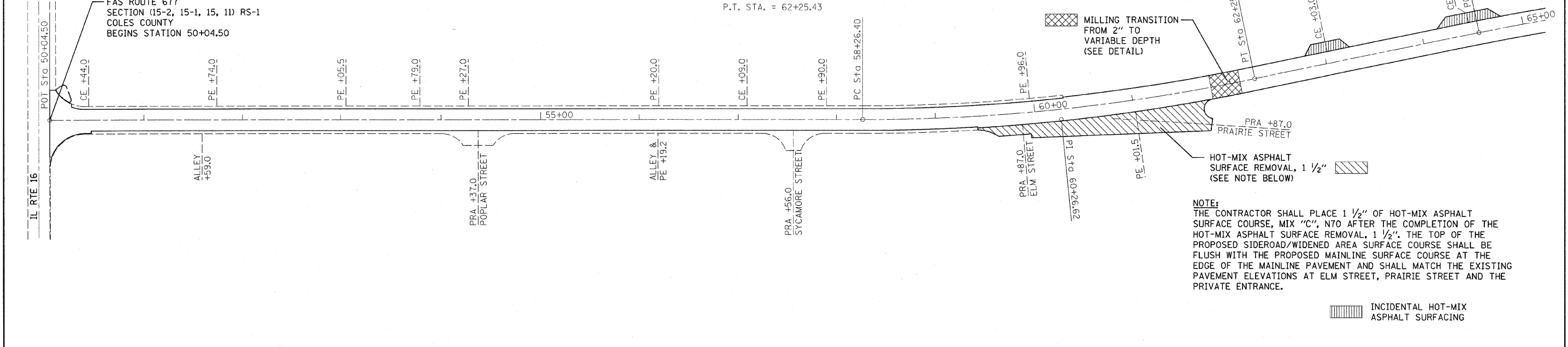

NOTE:
 THE CONTRACTOR SHALL PLACE 1 1/2" OF HOT-MIX ASPHALT SURFACE COURSE, MIX "C", N70 AFTER THE COMPLETION OF THE HOT-MIX ASPHALT SURFACE REMOVAL, 1 1/2". THE TOP OF THE PROPOSED SIDEROAD/WIDENED AREA SURFACE COURSE SHALL BE FLUSH WITH THE PROPOSED MAINLINE SURFACE COURSE AT THE EDGE OF THE MAINLINE PAVEMENT AND SHALL MATCH THE EXISTING PAVEMENT ELEVATIONS AT ELM STREET, PRAIRIE STREET AND THE PRIVATE ENTRANCE.

INCIDENTAL HOT-MIX ASPHALT SURFACING

EXIST. CURVE CUR2
 PI STA. = 69+20.34
 $\Delta = 30^\circ 15' 09''$ (RT)
 $D = 3^\circ 20' 08''$
 $R = 1,717.72'$
 $T = 464.32'$
 $L = 906.97'$
 $E = 61.65'$
 $e =$ -----
 $T.R. =$ -----
 $S.E. RUN =$ -----
 $P.C. STA. = 64+56.01$
 $P.T. STA. = 73+62.98$

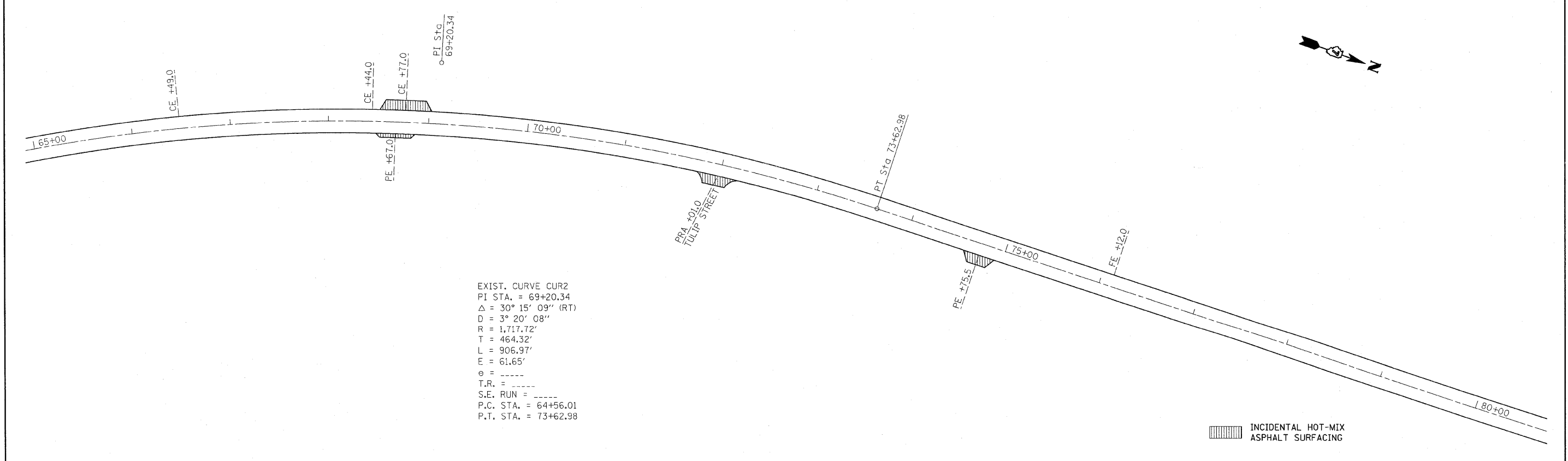

INCIDENTAL HOT-MIX ASPHALT SURFACING

FILE NAME =	USER NAME = swartzw	DESIGNED -	REVISED -	STATE OF ILLINOIS DEPARTMENT OF TRANSPORTATION	PLAN SHEET		F.A.S. RTE. 677	SECTION (15-2,15-1,15,11)RS-1	COUNTY COLES	TOTAL SHEETS 63	SHEET NO. 20	
ci:\pw_work\pwi\dot\swartzw\108242172\d77	607-shr-plan.dgn	DRAWN -	REVISED -		SCALE: 50	SHEET NO. 1 OF 15 SHEETS	STA. 50+04.50 TO STA. 80+00	CONTRACT NO. 74507				
		CHECKED -	REVISED -		ILLINOIS FED. AID PROJECT							
		DATE -	REVISED -									

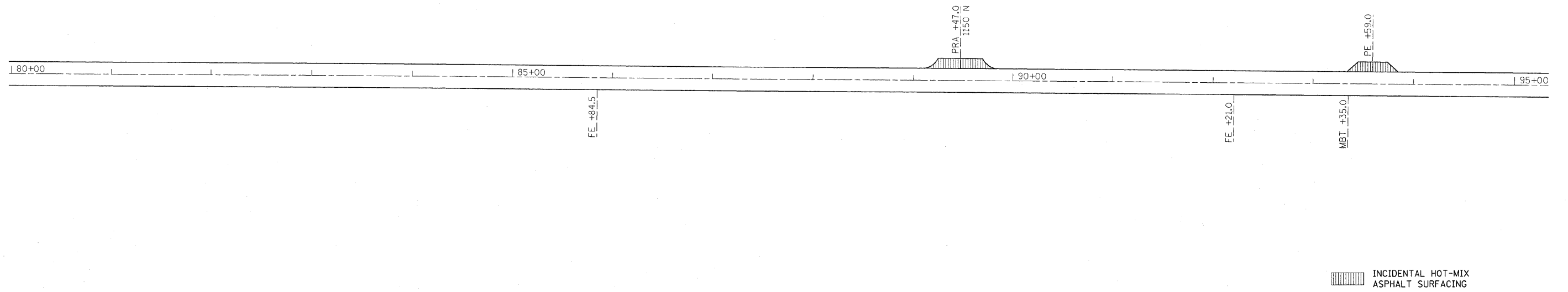

INCIDENTAL HOT-MIX ASPHALT SURFACING

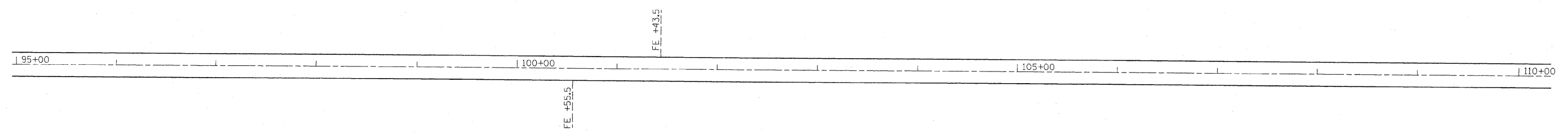

FILE NAME =	USER NAME = swartzw	DESIGNED -	REVISED -	STATE OF ILLINOIS DEPARTMENT OF TRANSPORTATION	PLAN SHEET			F.A.S. RTE.	SECTION	COUNTY	TOTAL SHEETS	SHEET NO.	
c:\pw_work\pwsdot\swartzw\d0242172\d77	007-shr-plan.dgn	DRAWN -	REVISED -		SCALE: 50	SHEET NO. 2 OF 15 SHEETS	STA. 80+00	TO STA. 110+00	677	(15-2,15-1,15,11)RS-1	COLES	63	21
	PLOT SCALE = 50.0000' / IN.	CHECKED -	REVISED -		CONTRACT NO. 74507								
	PLOT DATE = 1/31/2011	DATE -	REVISED -		ILLINOIS FED. AID PROJECT								

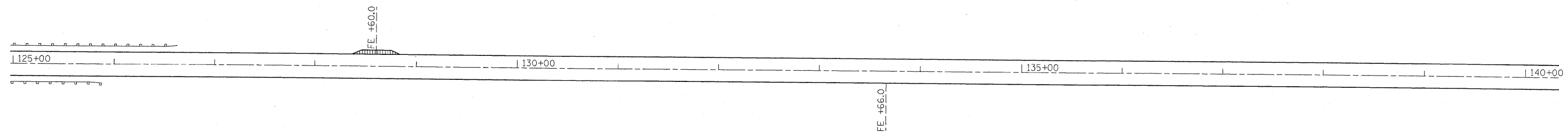
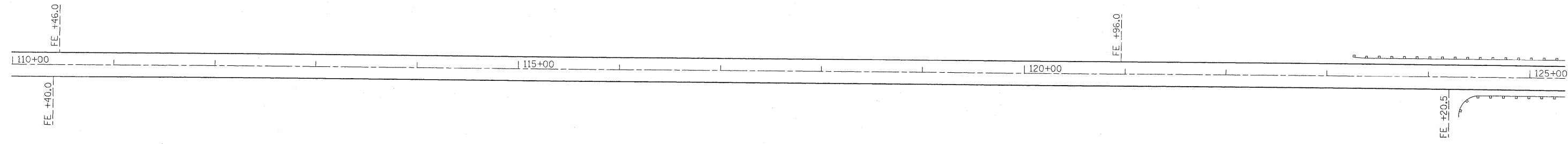

 INCIDENTAL HOT-MIX ASPHALT SURFACING

FILE NAME = e:\pw_work\pwidot\swartzrw\d0242172\d77	USER NAME = swartzrw	DESIGNED -	REVISED -	STATE OF ILLINOIS DEPARTMENT OF TRANSPORTATION	PLAN SHEET			F.A.S. RTE. 677	SECTION (15-2,15-1,15,11)RS-1	COUNTY COLES	TOTAL SHEETS 63	SHEET NO. 22
	507-shrt-plan.dgn	DRAWN -	REVISED -		SCALE: 50 SHEET NO. 3 OF 15 SHEETS STA. 110+00 TO STA. 140+00			CONTRACT NO. 74507				
PLOT SCALE = 50.0000' / IN.	CHECKED -	REVISED -	REVISED -		ILLINOIS FED. AID PROJECT							
PLOT DATE = 1/31/2011	DATE -	REVISED -	REVISED -									

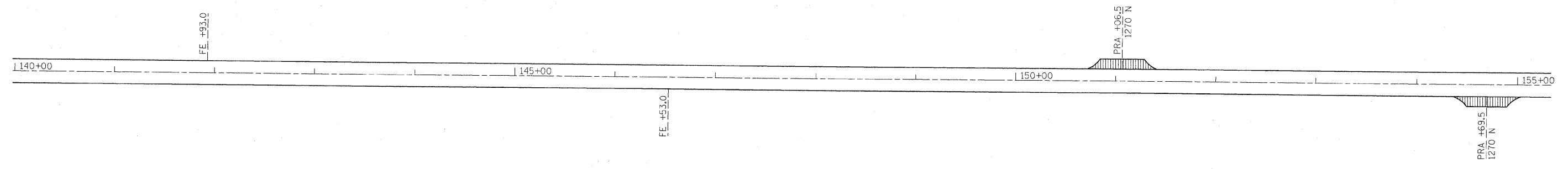

INCIDENTAL HOT-MIX ASPHALT SURFACING

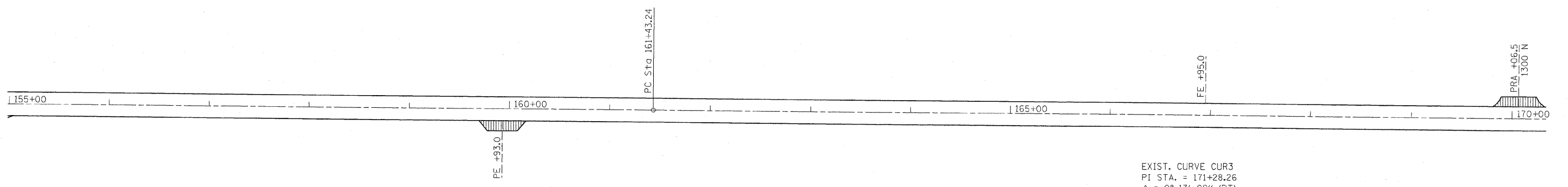

EXIST. CURVE CUR3
 PI STA. = 171+28.26
 Δ = 0° 13' 09" (RT)
 D = 0° 00' 40"
 R = 515,021.64'
 T = 985.02'
 L = 1,970.04'
 E = 0.94'
 e = -----
 T.R. = -----
 S.E. RUN = -----
 P.C. STA. = 161+43.24
 P.T. STA. = 181+13.28

INCIDENTAL HOT-MIX ASPHALT SURFACING

FILE NAME =	USER NAME = swartzrw	DESIGNED -	REVISED -	STATE OF ILLINOIS DEPARTMENT OF TRANSPORTATION	PLAN SHEET		F.A.S. RTE.	SECTION	COUNTY	TOTAL SHEETS	SHEET NO.	
c:\pw\work\pwsdot\swartzrw\d0242172\d77	507-sht-plan.dgn	DRAWN -	REVISED -		SCALE: 50	SHEET NO. 4 OF 15 SHEETS	STA. 140+00 TO STA. 170+00	677	(15-2.15-1.15.11)RS-1	COLES	63	23
	PLOT SCALE = 50.0000 ' / IN.	CHECKED -	REVISED -						CONTRACT NO. 74507			
	PLOT DATE = 1/31/2011	DATE -	REVISED -						ILLINOIS FED. AID PROJECT			

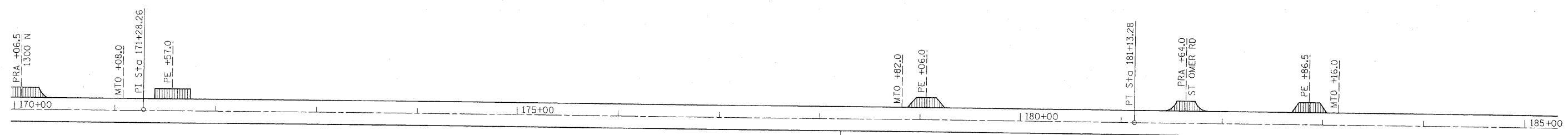
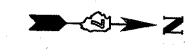

EXIST. CURVE CUR3
 PI STA. = 171+28.26
 $\Delta = 0^\circ 13' 09''$ (RT)
 $D = 0^\circ 00' 40''$
 $R = 515,021.64'$
 $T = 985.02'$
 $L = 1,970.04'$
 $E = 0.94'$
 $e =$
 $T.R. =$
 $S.E. RUN =$
 $P.C. STA. = 161+43.24$
 $P.T. STA. = 181+13.28$

INCIDENTAL HOT-MIX ASPHALT SURFACING

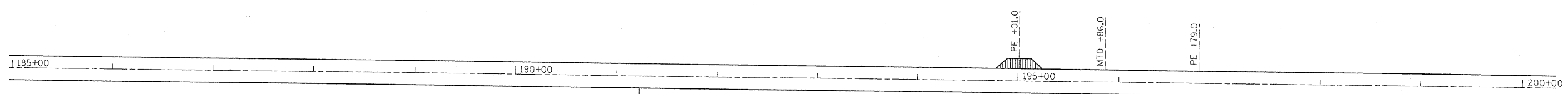

INCIDENTAL HOT-MIX ASPHALT SURFACING

FILE NAME =	USER NAME = swartzw	DESIGNED -	REVISED -	STATE OF ILLINOIS DEPARTMENT OF TRANSPORTATION	PLAN SHEET			F.A.S. RTE.	SECTION	COUNTY	TOTAL SHEETS	SHEET NO.
c:\pwwork\pwwork\swartzw\d0242172\d77	507-shit-plan.dgn	DRAWN -	REVISED -		677	(15-2,15-1,15,11)RS-1	COLES	63	24			
	PLOT SCALE = 50.0000' / IN.	CHECKED -	REVISED -		SCALE: 50 SHEET NO. 5 OF 15 SHEETS STA. 170+00 TO STA. 200+00			CONTRACT NO. 74507				
	PLOT DATE = 1/31/2011	DATE -	REVISED -		ILLINOIS FED. AID PROJECT							

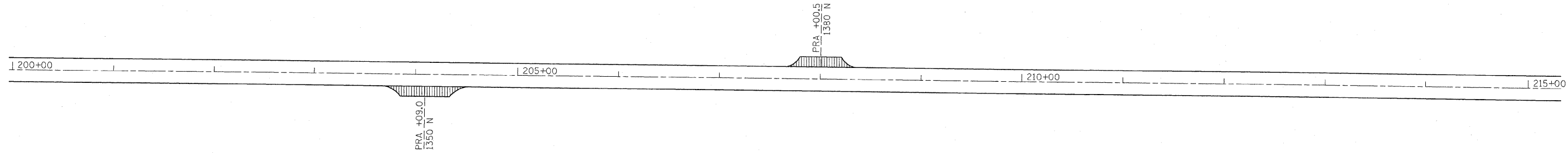

INCIDENTAL HOT-MIX ASPHALT SURFACING

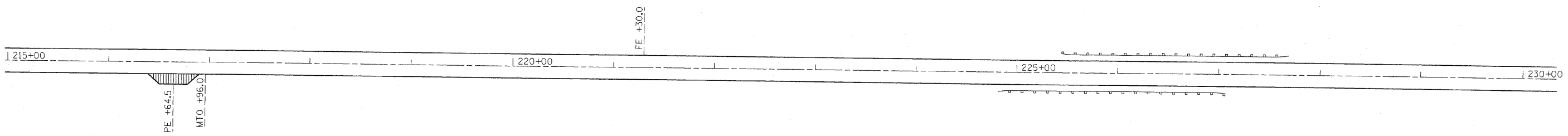

INCIDENTAL HOT-MIX ASPHALT SURFACING

FILE NAME =	USER NAME = swartzw	DESIGNED -	REVISED -	STATE OF ILLINOIS DEPARTMENT OF TRANSPORTATION	PLAN SHEET			F.A.S. RTE.:	SECTION	COUNTY	TOTAL SHEETS	SHEET NO.
ct:\pwork\pwidot\swartzw\0242172\d77	507-sht-plan.dgn	DRAWN -	REVISED -		677	(15-2,15-1,15,11)RS-1	COLES	63	25			
PLOT SCALE = 50.0000' / IN.	CHECKED -	REVISED -	SCALE: 50		SHEET NO. 6 OF 15 SHEETS	STA. 200+00 TO STA. 230+00	CONTRACT NO. 74507		ILLINOIS FED. AID PROJECT			
PLOT DATE = 1/31/2011	DATE -	REVISED -										

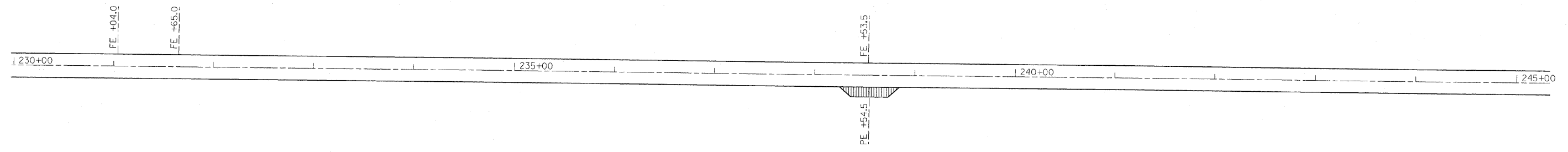

INCIDENTAL HOT-MIX ASPHALT SURFACING

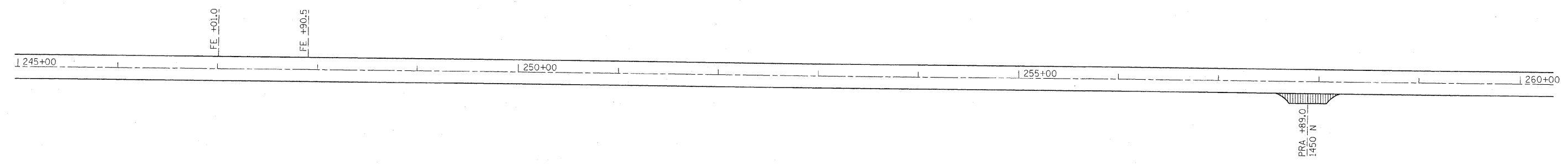

INCIDENTAL HOT-MIX ASPHALT SURFACING

FILE NAME =	USER NAME = swartzw	DESIGNED -	REVISED -	STATE OF ILLINOIS DEPARTMENT OF TRANSPORTATION	PLAN SHEET			F.A.S. RTE.	SECTION	COUNTY	TOTAL SHEETS	SHEET NO.
c:\pw_work\pwidot\swartzw\0242172\077	507-shr-plan.dgn	DRAWN -	REVISED -		SCALE: 50	SHEET NO. 7 OF 15 SHEETS	STA. 230+00 TO STA. 260+00	677	(15-2,15-1,15,11)RS-1	COLES	63	26
	PLOT SCALE = 50.0000' / IN.	CHECKED -	REVISED -		CONTRACT NO. 74507							
	PLOT DATE = 1/31/2011	DATE -	REVISED -		ILLINOIS FED. AID PROJECT							

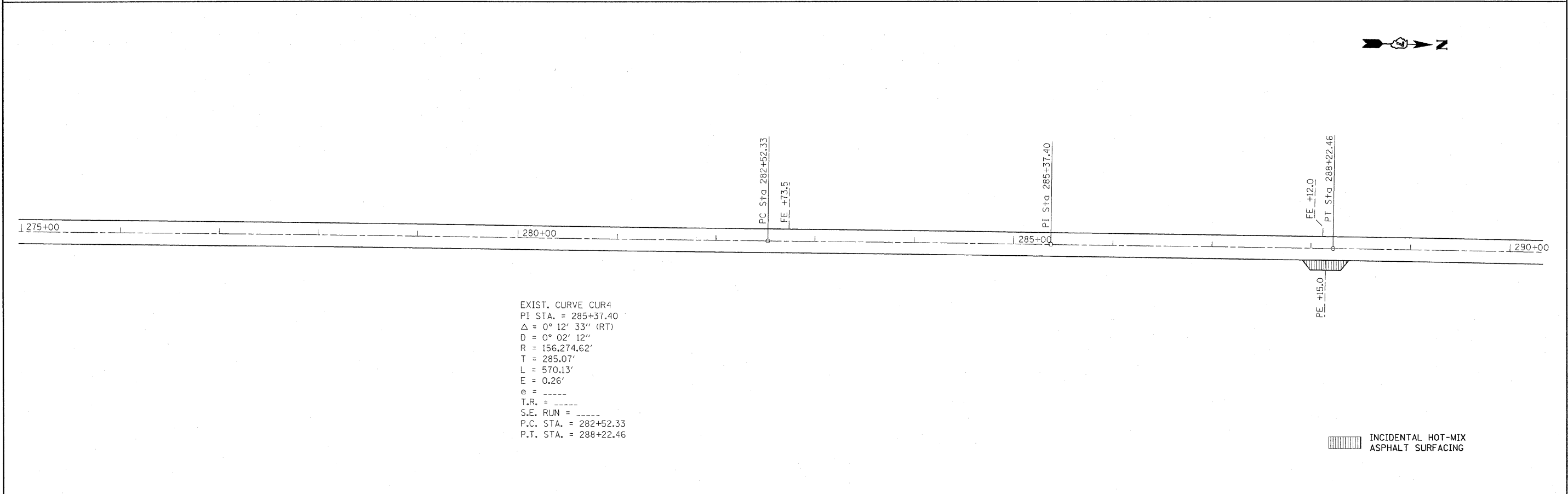
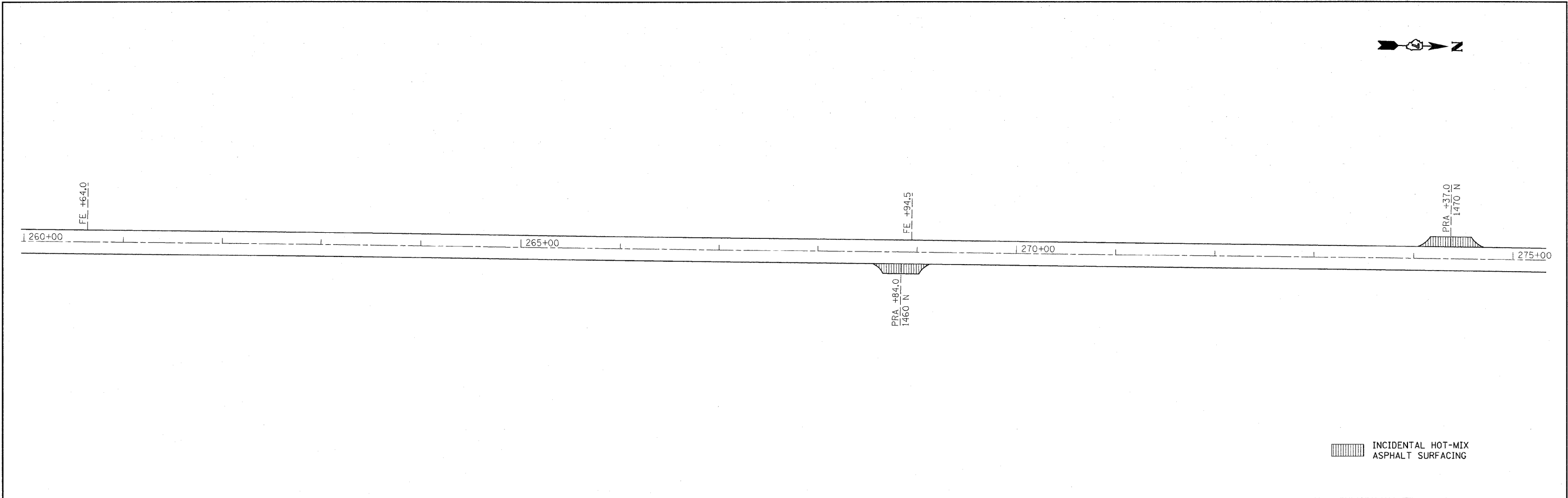

EXIST. CURVE CUR4
 PI STA. = 285+37.40
 $\Delta = 0^\circ 12' 33''$ (RT)
 $D = 0^\circ 02' 12''$
 $R = 156,274.62'$
 $T = 285.07'$
 $L = 570.13'$
 $E = 0.26'$
 $e = \text{-----}$
 $T.R. = \text{-----}$
 $S.E. RUN = \text{-----}$
 P.C. STA. = 282+52.33
 P.T. STA. = 288+22.46

FILE NAME =	USER NAME = swartzw	DESIGNED -	REVISED -	STATE OF ILLINOIS DEPARTMENT OF TRANSPORTATION	PLAN SHEET		F.A.S. RTE.	SECTION	COUNTY	TOTAL SHEETS	SHEET NO.	
c:\pv_work\pvidot\swartzw\d8242172\d77	607-sht-plan.dgn	DRAWN -	REVISED -		SCALE: 50	SHEET NO. 8 OF 15 SHEETS	STA. 260+00 TO STA. 290+00	677	(15-2,15-1,15,11)RS-1	COLES	63	27
	PLOT SCALE = 50,0000 ' / IN.	CHECKED -	REVISED -		CONTRACT NO. 74507							
	PLOT DATE = 1/31/2011	DATE -	REVISED -		ILLINOIS FED. AID PROJECT							

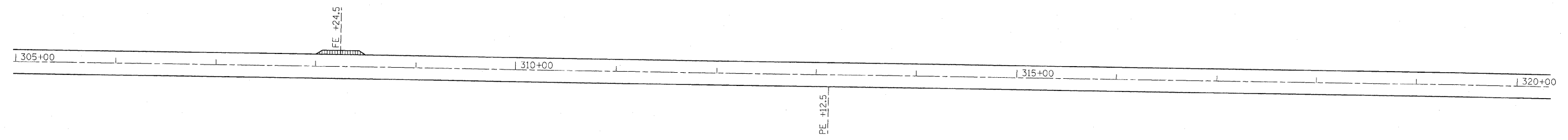
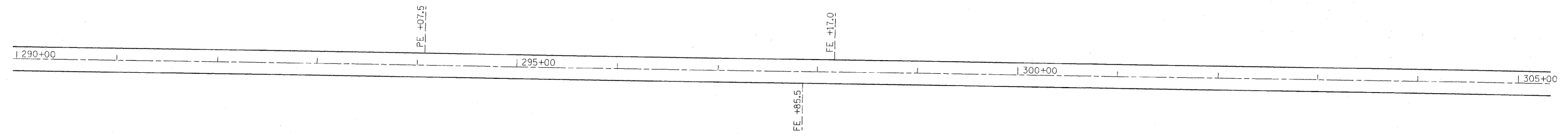

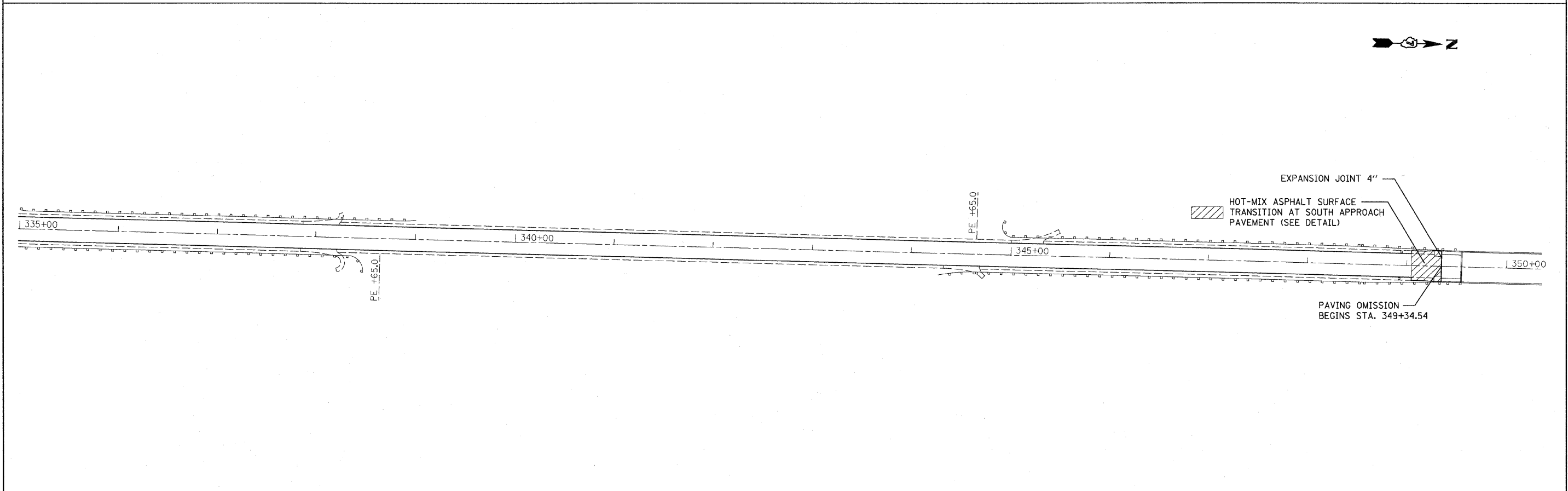
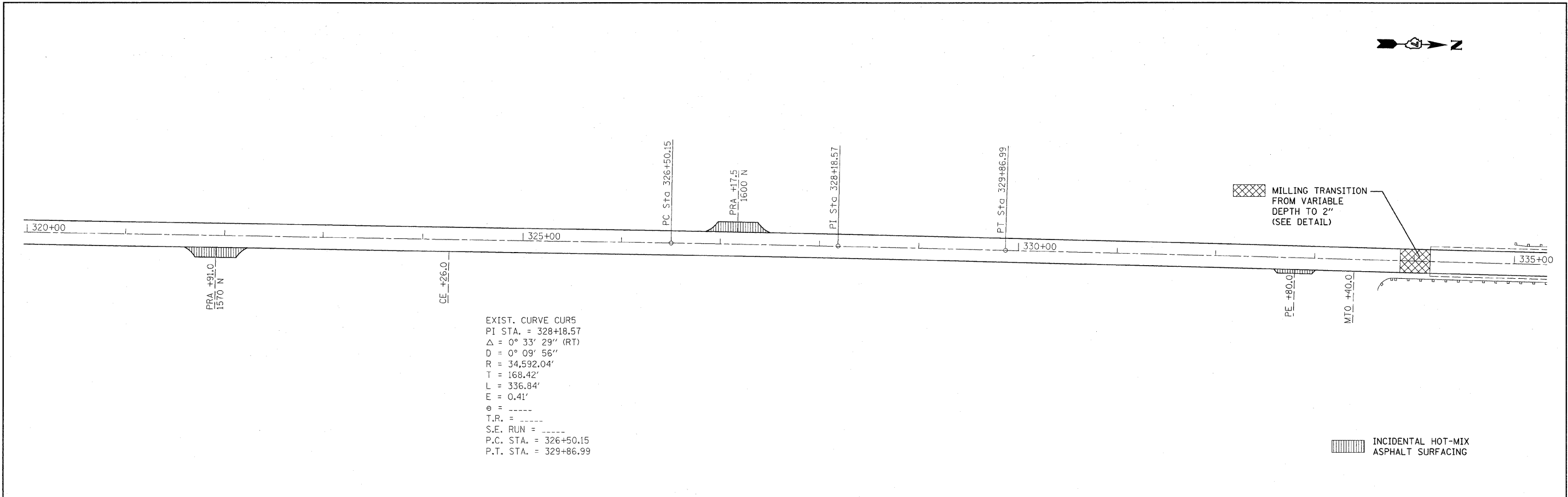

 INCIDENTAL HOT-MIX ASPHALT SURFACING

FILE NAME =	USER NAME = swartzw	DESIGNED -	REVISED -	STATE OF ILLINOIS DEPARTMENT OF TRANSPORTATION	PLAN SHEET			F.A.S. RTE.	SECTION	COUNTY	TOTAL SHEETS	SHEET NO.
c:\pwork\pwork\swartzw\08242172\177-507-sht-plan.dgn		DRAWN -	REVISED -		SCALE: 50	SHEET NO. 9 OF 15 SHEETS	STA. 290+00 TO STA. 320+00	677	(15-2,15-1,15,11)RS-1	COLES	63	28
PLOT SCALE = 50.0000' / IN.		CHECKED -	REVISED -					CONTRACT NO. 74507				
PLOT DATE = 1/31/2011		DATE -	REVISED -					ILLINOIS FED. AID PROJECT				

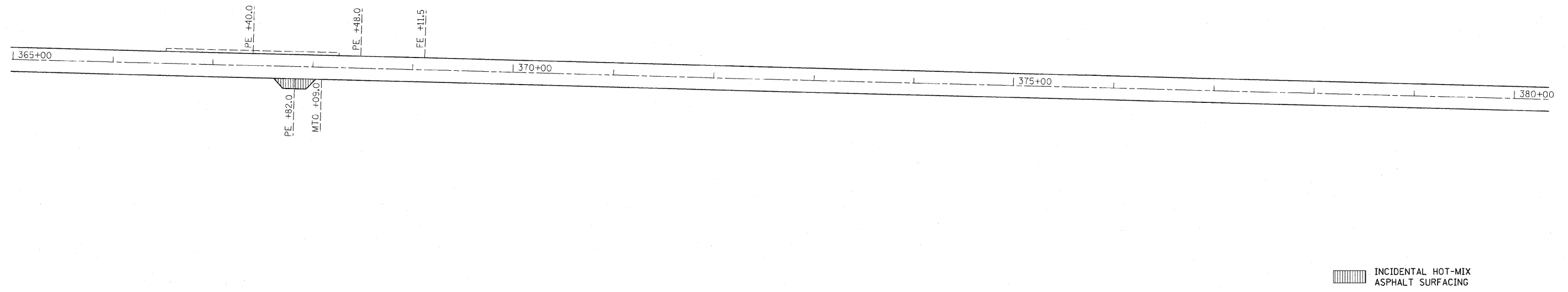
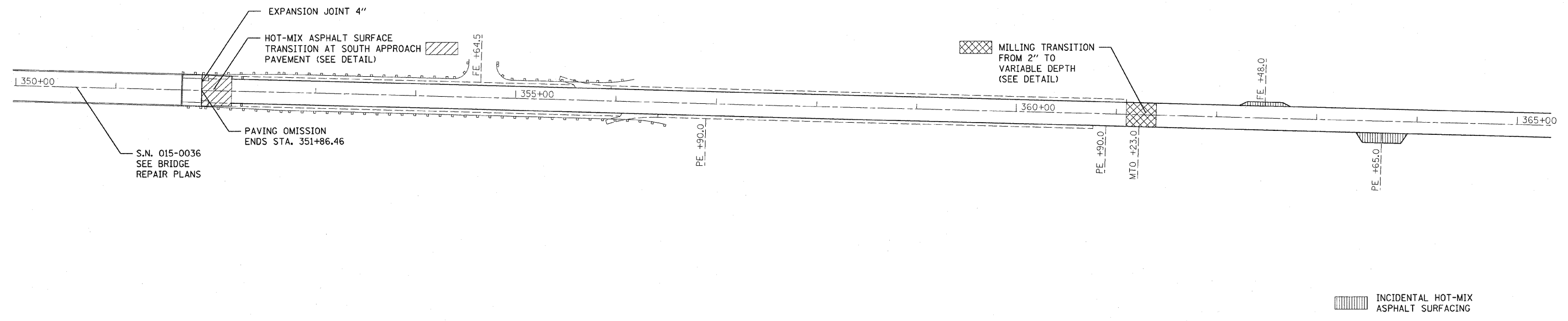

FILE NAME =	USER NAME = swartzw	DESIGNED -	REVISED -	STATE OF ILLINOIS DEPARTMENT OF TRANSPORTATION	PLAN SHEET		F.A.S. RTE.	SECTION	COUNTY	TOTAL SHEETS	SHEET NO.	
c:\pwwork\pwwork\swartzw\d0242172\d77	507-sht-plan.dgn	DRAWN -	REVISED -		SCALE: 50	SHEET NO. 10 OF 15 SHEETS	STA. 320+00 TO STA. 350+00	677	(15-2,15-1,15,11)RS-1	COLES	63	29
	PLOT SCALE = 50.0000' / IN.	CHECKED -	REVISED -								CONTRACT NO. 74507	
	PLOT DATE = 1/31/2011	DATE -	REVISED -								ILLINOIS FED. AID PROJECT	



INCIDENTAL HOT-MIX ASPHALT SURFACING

FILE NAME =	USER NAME = swartzw	DESIGNED -	REVISED -	STATE OF ILLINOIS DEPARTMENT OF TRANSPORTATION	PLAN SHEET			F.A.S. RTE.	SECTION	COUNTY	TOTAL SHEETS	SHEET NO.
c:\pwork\pwork\swartzw\d8242172\d77	507-shr-plan.dgn	DRAWN -	REVISED -		SCALE: 50	SHEET NO. 11 OF 15 SHEETS	STA. 350+00 TO STA. 380+00	677	(15-2,15-1,15,11)RS-1	COLES	63	30
	PLOT SCALE = 50.0000' / IN.	CHECKED -	REVISED -					CONTRACT NO. 74507				
	PLOT DATE = 1/31/2011	DATE -	REVISED -					ILLINOIS FED. AID PROJECT				

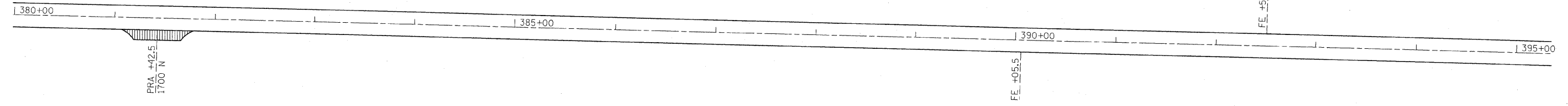

INCIDENTAL HOT-MIX ASPHALT SURFACING

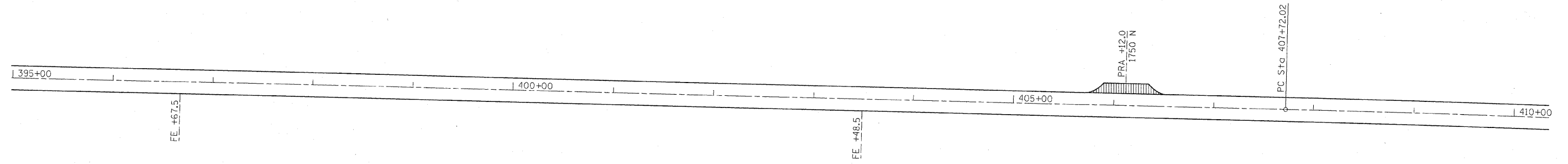

EXIST. CURVE CUR6
 PI STA. = 410+45.26
 Δ = 0° 48' 49" (RT)
 D = 0° 08' 56"
 R = 38,482.84'
 T = 273.23'
 L = 546.46'
 E = 0.97'
 e = -----
 T.R. = -----
 S.E. RUN = -----
 P.C. STA. = 407+72.02
 P.T. STA. = 413+18.48

INCIDENTAL HOT-MIX ASPHALT SURFACING

FILE NAME =	USER NAME = swartzw	DESIGNED -	REVISED -	STATE OF ILLINOIS DEPARTMENT OF TRANSPORTATION	PLAN SHEET		F.A.S. RTE.	SECTION	COUNTY	TOTAL SHEETS	SHEET NO.	
c:\pw\work\pvidot\swartzw\d8242172\d77	607-shr-plan.dgn	DRAWN -	REVISED -		SCALE: 50	SHEET NO. 12 OF 15 SHEETS	STA. 380+00 TO STA. 410+00	677	(15-2,15-1,15,11)RS-1	COLES	63	31
	PLOT SCALE = 50.0000' / IN.	CHECKED -	REVISED -					CONTRACT NO. 74507				
	PLOT DATE = 1/31/2011	DATE -	REVISED -					ILLINOIS FED. AID PROJECT				

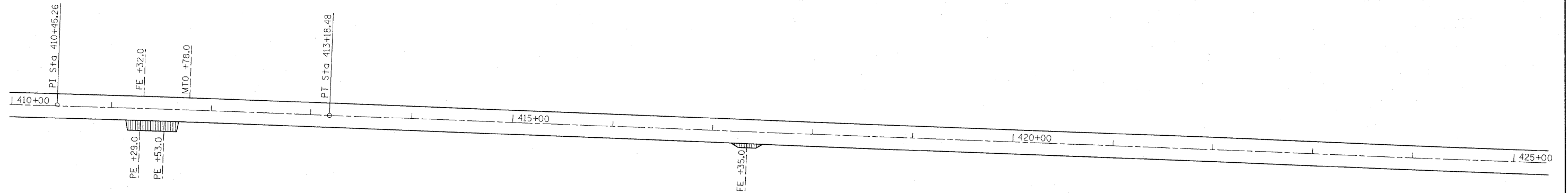

EXIST. CURVE CUR6
 PI STA. = 410+45.26
 Δ = 0° 48' 49" (RT)
 D = 0° 08' 56"
 R = 38,482.84'
 T = 273.23'
 L = 546.46'
 E = 0.97'
 e = -----
 T.R. = -----
 S.E. RUN = -----
 P.C. STA. = 407+72.02
 P.T. STA. = 413+18.48

 INCIDENTAL HOT-MIX ASPHALT SURFACING

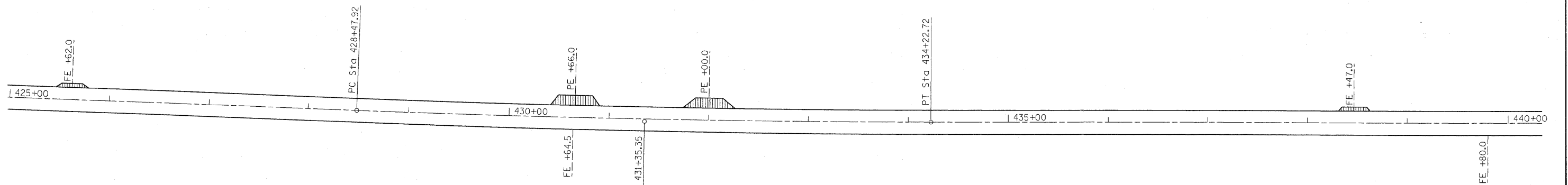

EXIST. CURVE CUR7
 PI STA. = 431+35.35
 Δ = 2° 06' 18" (LT)
 D = 0° 21' 58"
 R = 15,645.49'
 T = 287.43'
 L = 574.80'
 E = 2.64'
 e = -----
 T.R. = -----
 S.E. RUN = -----
 P.C. STA. = 428+47.92
 P.T. STA. = 434+22.72

 INCIDENTAL HOT-MIX ASPHALT SURFACING

FILE NAME =	USER NAME = swartzw	DESIGNED -	REVISED -
c:\pwork\pwork\swartzw\d0242172\d77	507-ahp-plan.dgn	DRAWN -	REVISED -
	PLOT SCALE = 50.0000' / IN.	CHECKED -	REVISED -
	PLOT DATE = 1/31/2011	DATE -	REVISED -

STATE OF ILLINOIS
 DEPARTMENT OF TRANSPORTATION

PLAN SHEET

SCALE: 50 SHEET NO. 13 OF 15 SHEETS STA. 410+00 TO STA. 440+00

F.A.S. RTE.	SECTION	COUNTY	TOTAL SHEETS	SHEET NO.
677	(15-2,15-1,15,11)RS-1	COLES	63	32
CONTRACT NO. 74507			ILLINOIS FED. AID PROJECT	



1440+00 1445+00 1450+00 1455+00

FE +76.0

FE +72.0

MTD +40.5

PE +40.5

INCIDENTAL HOT-MIX ASPHALT SURFACING



1455+00 1460+00 1465+00 1470+00

FE +19.0

FE +41.0

PC Sta. 465+34.21

PI Sta. 467+78.55

PT Sta. 470+22.86

FE +00.0

EXIST. CURVE CUR8
PI STA. = 467+78.55
 $\Delta = 1^\circ 14' 17''$ (RT)
D = $0^\circ 15' 12''$
R = 22,613.05'
T = 244.33'
L = 488.65'
E = 1.32'
O = -----
T.R. = -----
S.E. RUN = -----
P.C. STA. = 465+34.21
P.T. STA. = 470+22.86

FILE NAME =	USER NAME = swartzrw	DESIGNED -	REVISED -
ca:\pwork\pwork\swartzrw\d0242172\d77	507-shs:plan.dgn	DRAWN -	REVISED -
	PLOT SCALE = 50,0000 1 / IN.	CHECKED -	REVISED -
	PLOT DATE = 1/31/2011	DATE -	REVISED -

**STATE OF ILLINOIS
DEPARTMENT OF TRANSPORTATION**

PLAN SHEET

SCALE: 50 SHEET NO. 14 OF 15 SHEETS STA. 440+00 TO STA. 470+00

F.A.S. RTE.	SECTION	COUNTY	TOTAL SHEETS	SHEET NO.
677	(15-2,15-1,15,11)RS-1	COLES	63	33
CONTRACT NO. 74507			ILLINOIS FED. AID PROJECT	

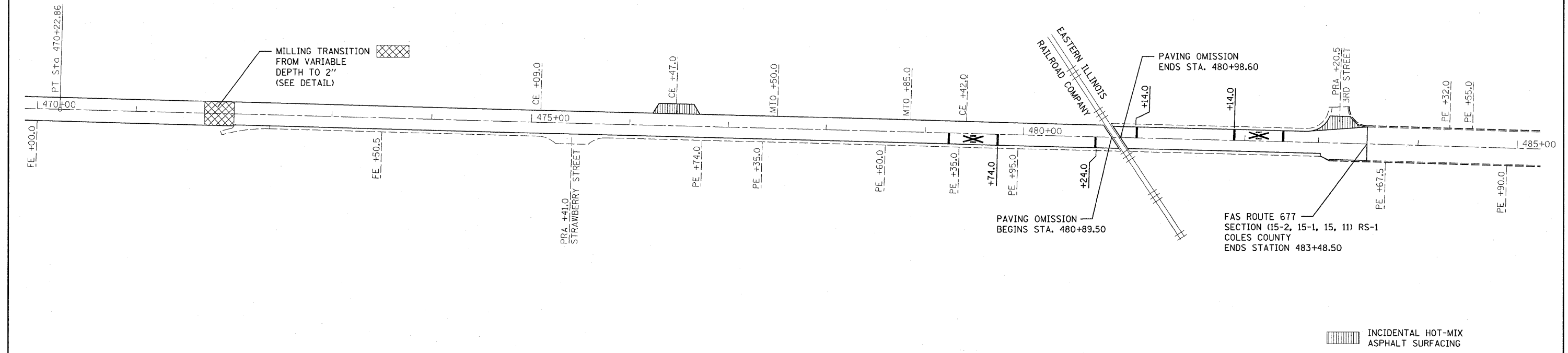

INCIDENTAL HOT-MIX ASPHALT SURFACING

FILE NAME =	USER NAME = swartzw	DESIGNED -	REVISED -
es:\pwwork\pwwork\swartzw\d0242172\d77	507-sht-plan.dgn	DRAWN -	REVISED -
	PLOT SCALE = 50.0000 ' / IN.	CHECKED -	REVISED -
	PLOT DATE = 1/31/2011	DATE -	REVISED -

**STATE OF ILLINOIS
DEPARTMENT OF TRANSPORTATION**

PLAN SHEET

SCALE: 50 SHEET NO. 15 OF 15 SHEETS STA. 470+00 TO STA. 483+48.50

F.A.S. RTE.	SECTION	COUNTY	TOTAL SHEETS	SHEET NO.
677	(15-2,15-1,15,11)RS-1	COLES	63	34
CONTRACT NO. 74507				
ILLINOIS FED. AID PROJECT				

TEMPORARY CONCRETE BARRIER

348+26.4 TO 352+94.6 470.0 FOOT
 TOTAL = 470.0 FOOT

TEMPORARY RUMBLE STRIPS

TOTAL = 6.0 EACH

IMPACT ATTENUATORS, TEMPORARY
 (NON-REDIRECTIVE), TEST LEVEL 3



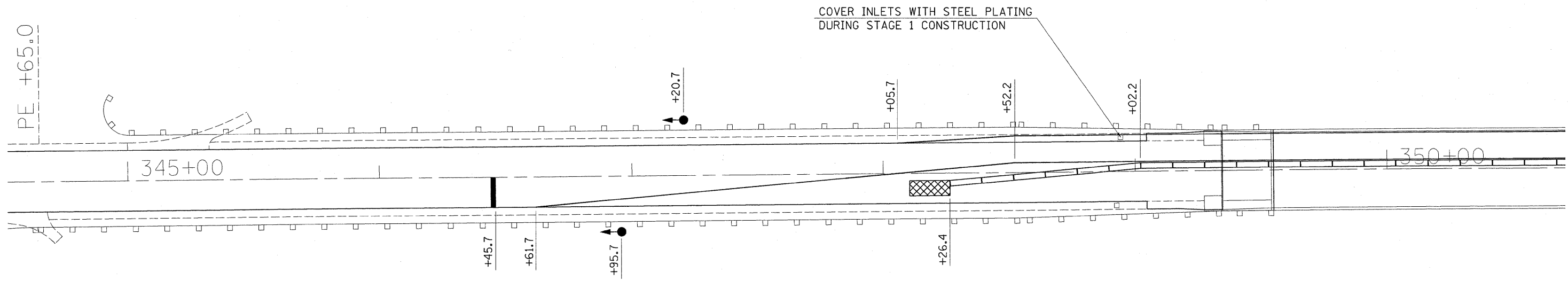

348+26.4 1.0 EACH
 352+94.6 1.0 EACH
 TOTAL = 2.0 EACH

TEMPORARY BRIDGE TRAFFIC SIGNALS

S. N. 015-0036 1.0 EACH
 TOTAL = 1.0 EACH

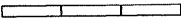

LEGEND



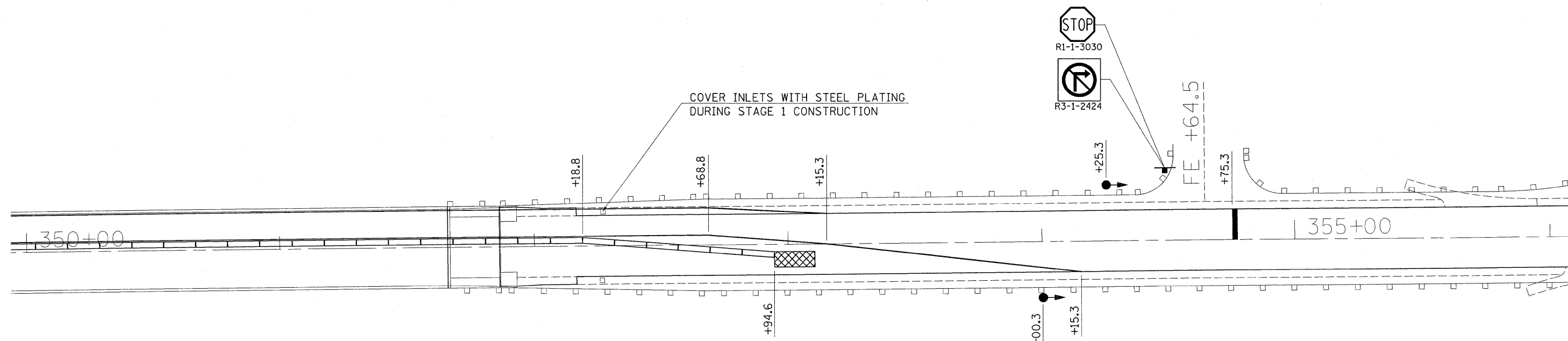

-  TEMPORARY BRIDGE TRAFFIC SIGNAL
-  IMPACT ATTENUATORS, TEMPORARY (NON-REDIRECTIVE) TEST LEVEL 3
-  TEMPORARY CONCRETE BARRIER
-  STOP BAR

NOTE:
 TRAFFIC CONTROL ITEMS NOT SHOWN; INCLUDING SIGNS, DETECTOR
 LOOPS, TEMPORARY RUMBLE STRIPS AND OTHER ITEMS REQUIRED
 SHALL BE IN ACCORDANCE WITH HIGHWAY STANDARD 701321-11

FILE NAME =	USER NAME = swartzw	DESIGNED -	REVISED -	STATE OF ILLINOIS DEPARTMENT OF TRANSPORTATION	STAGE 1 TRAFFIC CONTROL			F.A.S. RTE.	SECTION	COUNTY	TOTAL SHEETS	SHEET NO.	
es:\pwork\pwork\swartzw\d0242172\d77	507-sht-trafficcontrolstaging.dgn	DRAWN -	REVISED -		677	(15-2,15-1,15,11)RS-1	COLES	35	35				
	PLOT SCALE = 20.0000 1/ IN.	CHECKED -	REVISED -		SCALE: 20			SHEET NO. 1 OF 4 SHEETS		STA. 345+00 TO STA. 350+00		CONTRACT NO. 74507	
	PLOT DATE = 1/31/2011	DATE -	REVISED -		ILLINOIS FED. AID PROJECT								

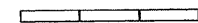

LEGEND

-  TEMPORARY BRIDGE TRAFFIC SIGNAL
-  IMPACT ATTENUATORS, TEMPORARY (NON-REDIRECTIVE) TEST LEVEL 3
-  TEMPORARY CONCRETE BARRIER
-  STOP BAR

NOTE:
 TRAFFIC CONTROL ITEMS NOT SHOWN; INCLUDING SIGNS, DETECTOR LOOPS, TEMPORARY RUMBLE STRIPS AND OTHER ITEMS REQUIRED SHALL BE IN ACCORDANCE WITH HIGHWAY STANDARD 701321-11

FILE NAME =	USER NAME = swartzw	DESIGNED -	REVISED -	STATE OF ILLINOIS DEPARTMENT OF TRANSPORTATION	STAGE 1 TRAFFIC CONTROL			F.A.S. RTE.	SECTION	COUNTY	TOTAL SHEETS	SHEET NO.
ca:\pwwork\pwwidot\swartzw\d0242172\d774	607-sh1-trafficcontroltaging.dgn	DRAWN -	REVISED -		SCALE: 20	SHEET NO. 2 OF 4 SHEETS	STA. 350+00 TO STA. 356+00	677	(15-2,15-1,15,11)RS-1	COLES	63	36
	PLOT SCALE = 20.0000' / IN.	CHECKED -	REVISED -		ILLINOIS FED. AID PROJECT							
	PLOT DATE = 1/31/2011	DATE -	REVISED -		CONTRACT NO. 74507							

RELOCATE TEMPORARY CONCRETE BARRIER

348+26.4 TO 352+94.6 470.0 FOOT
TOTAL = 470.0 FOOT



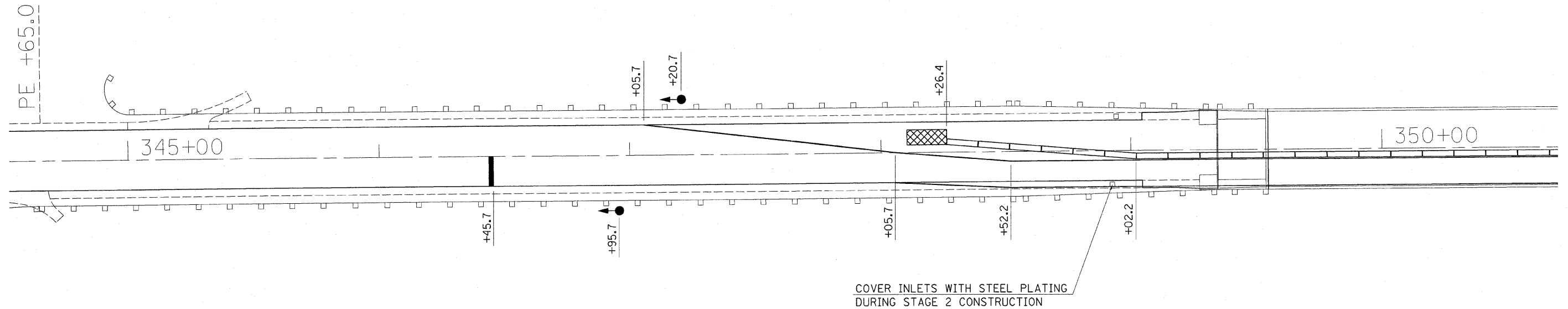

IMPACT ATTENUATORS, RELOCATE
(NON-REDIRECTIVE), TEST LEVEL 3

348+26.4 1.0 EACH
352+94.6 1.0 EACH
TOTAL = 2.0 EACH

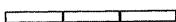

COVER INLETS WITH STEEL PLATING
DURING STAGE 2 CONSTRUCTION

LEGEND

-  TEMPORARY BRIDGE TRAFFIC SIGNAL
-  IMPACT ATTENUATORS, TEMPORARY
(NON-REDIRECTIVE) TEST LEVEL 3
-  TEMPORARY CONCRETE BARRIER
-  STOP BAR



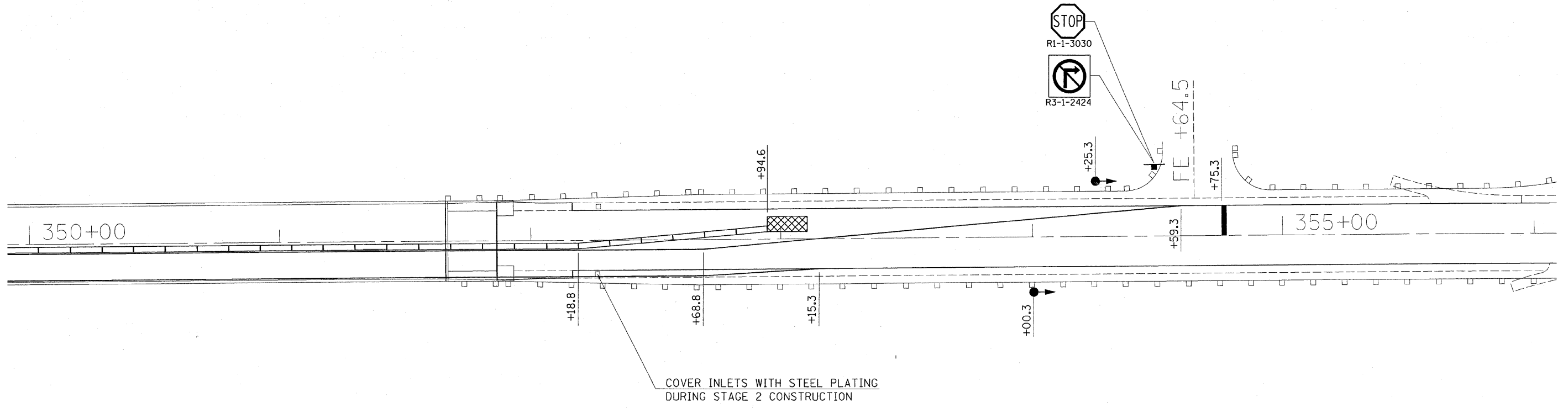
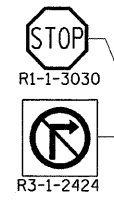
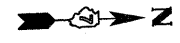

NOTE:
TRAFFIC CONTROL ITEMS NOT SHOWN; INCLUDING SIGNS, DETECTOR
LOOPS, TEMPORARY RUMBLE STRIPS AND OTHER ITEMS REQUIRED
SHALL BE IN ACCORDANCE WITH HIGHWAY STANDARD 701321-11

FILE NAME =	USER NAME = swartzw	DESIGNED -	REVISED -	STATE OF ILLINOIS DEPARTMENT OF TRANSPORTATION	STAGE 2 TRAFFIC CONTROL			F.A.S. RTE.	SECTION	COUNTY	TOTAL SHEETS	SHEET NO.
c:\pw\work\p\dot\swartzw\d0242172\d77	507-shr-trafficcontrolstaging.dgn	DRAWN -	REVISED -		SCALE: 20	SHEET NO. 3 OF 4 SHEETS	STA. 345+00 TO STA. 350+00	677	(15-2,15-1,15,11)RS-1	COLES	63	37
	PLOT SCALE = 20.0000 "/>											
	PLOT DATE = 1/31/2011	CHECKED -	REVISED -		ILLINOIS FED. AID PROJECT							
		DATE -	REVISED -									

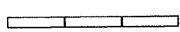

COVER INLETS WITH STEEL PLATING
DURING STAGE 2 CONSTRUCTION

LEGEND

-  TEMPORARY BRIDGE TRAFFIC SIGNAL
-  IMPACT ATTENUATORS, TEMPORARY (NON-REDIRECTIVE) TEST LEVEL 3
-  TEMPORARY CONCRETE BARRIER
-  STOP BAR

NOTE:
TRAFFIC CONTROL ITEMS NOT SHOWN; INCLUDING SIGNS, DETECTOR LOOPS, TEMPORARY RUMBLE STRIPS AND OTHER ITEMS REQUIRED SHALL BE IN ACCORDANCE WITH HIGHWAY STANDARD 701321-11

FILE NAME =	USER NAME = swartzw	DESIGNED -	REVISED -	STATE OF ILLINOIS DEPARTMENT OF TRANSPORTATION	STAGE 2 TRAFFIC CONTROL			F.A.S. RTE.	SECTION	COUNTY	TOTAL SHEETS	SHEET NO.
c:\pwwork\pwwork\swartzw\0242172\d77	507-shr-trafficcontrolstaging.dgn	DRAWN -	REVISED -		677	(15-2,15-1,15,11)RS-1	COLES	43	38			
	PLOT SCALE = 20,0000 1/ IN.	CHECKED -	REVISED -		SCALE: 20 SHEET NO. 4 OF 4 SHEETS STA. 350+00 TO STA. 356+00			CONTRACT NO. 74507				
	PLOT DATE = 1/31/2011	DATE -	REVISED -		ILLINOIS FED. AID PROJECT							

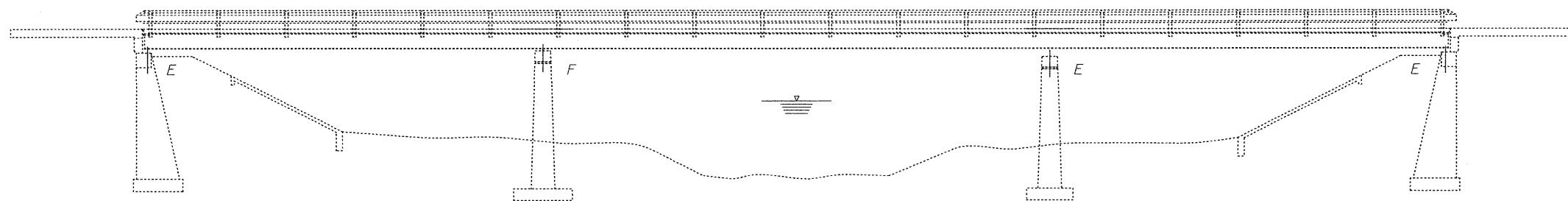

ELEVATION

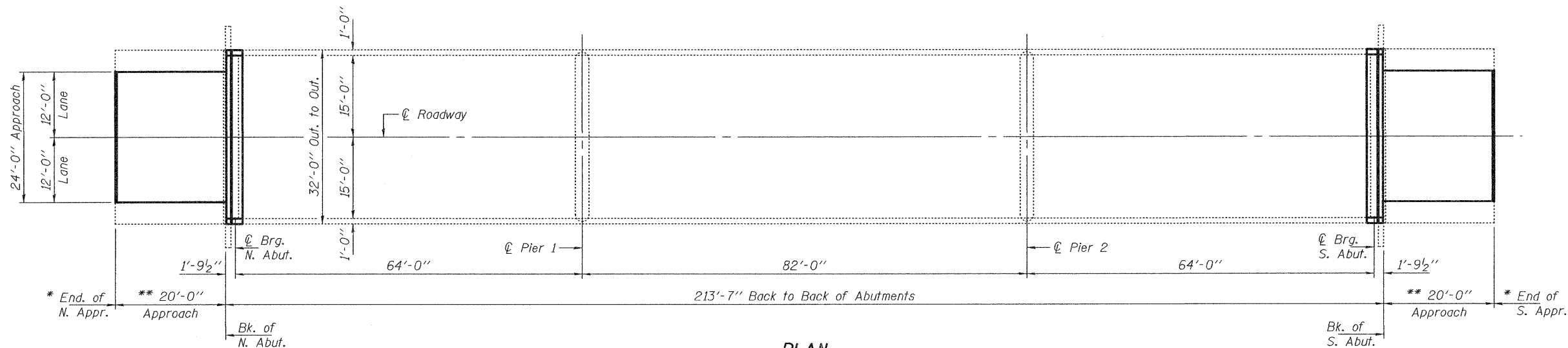

PLAN

* See Detail "A" on sheet 3 of 10 for end of approach details.

** See sheet 9 of 10 for Approach Cross-Section.

GENERAL NOTES

All structural steel shall conform to AASHTO Classification M-270 Gr. 36, unless otherwise noted.

Plan dimensions and details relative to existing plans are subject to nominal construction variations. The Contractor shall field verify existing dimensions and details affecting new construction and make necessary approved adjustments prior to construction or ordering of materials. Such variations shall not be cause for additional compensation for a change in scope of the work, however, the Contractor will be paid for the quantity actually furnished at the unit price bid for the work.

Reinforcement bars shall conform to the requirements of ASTM A 706 Gr 60. See Special Provisions.

Reinforcement bars designated (E) shall be epoxy coated.

Prior to pouring the new concrete deck, all heavy or loose rust, loose mill scale, and other loose or potentially detrimental foreign material shall be removed from the surfaces in contact with concrete. Tightly adhered paint may remain unless otherwise noted. Removal shall be accomplished by methods that will not damage the steel and the cost will be included in the pay item covering removal of the existing concrete.

Existing structural steel that will be in contact with new structural steel shall be cleaned and painted prior to erection as required by the Special Provision "Cleaning and Painting Contact Surface Areas of Existing Steel Structures".

All structural steel shall be shop painted with the inorganic zinc rich primer per AASHTO M300, Type I. Cost included with Furnishing and Erecting Structural Steel.

Existing reinforcement bars extending into the removal area shall be cleaned, straightened and incorporated into the new construction. Any reinforcement bars that are damaged during concrete removal shall be replaced with an approved bar splicer or anchorage system. Cost included with Concrete Removal.

The deck surface shall have its final finish tined according to Article 420.09(e)(1) of the Standard Specifications. Cost included with Concrete Superstructures.

Joint openings shall be adjusted according to Article 520.04 of the Standard Specifications when the deck is poured at an ambient temperature other than 50° F.

The removal and reinstallation of the rail post supports will be necessary at the abutments. Cost included with Concrete Superstructure.

TOTAL BILL OF MATERIAL

ITEM	UNIT	QUANTITY
Concrete Removal	Cu. Yd.	7.0
Concrete Superstructure	Cu. Yd.	7.8
Prefomed Joint Strip Seal	Foot	64
Bar Splicers	Each	22
Reinforcement Bars, Epoxy Coated	Pound	980
Jack and Remove Existing Bearings	Each	12
Elastomeric Bearing Assembly, Type I	Each	6
Elastomeric Bearing Assembly, Type II	Each	6
Furnishing & Erecting Structural Steel	Pound	1340
Anchor Bolts, 1"φ	Each	24
Bridge Deck Scarification, 3/4"	Sq. Yd.	827
Bridge Deck Microsilica Concrete Overlay, 2 1/4"	Sq. Yd.	825
Bridge Deck Grooving	Sq. Yd.	786
*** Protective Coat	Sq. Yd.	20
Deck Slab Repair (Full Depth, Type I)	Sq. Yd.	7
Deck Slab Repair (Full Depth, Type II)	Sq. Yd.	73
Polymer Concrete	Cu. Ft.	2.7

*** Protective Coat shall not be applied to surfaces which receive Bridge Deck Microsilica Concrete Overlay.



Expires: November 30, 2012

DESIGNED - Ally Nancy
 CHECKED - Dan J. Puzey
 DRAWN - Kyle M. Stoffen
 CHECKED - ADU IJL

EXAMINED - *Jan F. Jelliffe*
 ACTING ENGINEER OF STRUCTURAL SERVICES
 PASSED - *David Carl Puzey*
 ACTING ENGINEER OF BRIDGES AND STRUCTURES

DATE - MARCH 4, 2011

STATE OF ILLINOIS
 DEPARTMENT OF TRANSPORTATION

GENERAL PLAN & ELEVATION
 SN 015-0036

SHEET NO. 1 OF 10 SHEETS

F.A.S. RTE.	SECTION	COUNTY	TOTAL SHEETS	SHEET NO.
677	(15-2, 15-1, 15, 11)RS-1	COLES	65	39
CONTRACT NO. 74507			ILLINOIS FED. AID PROJECT	

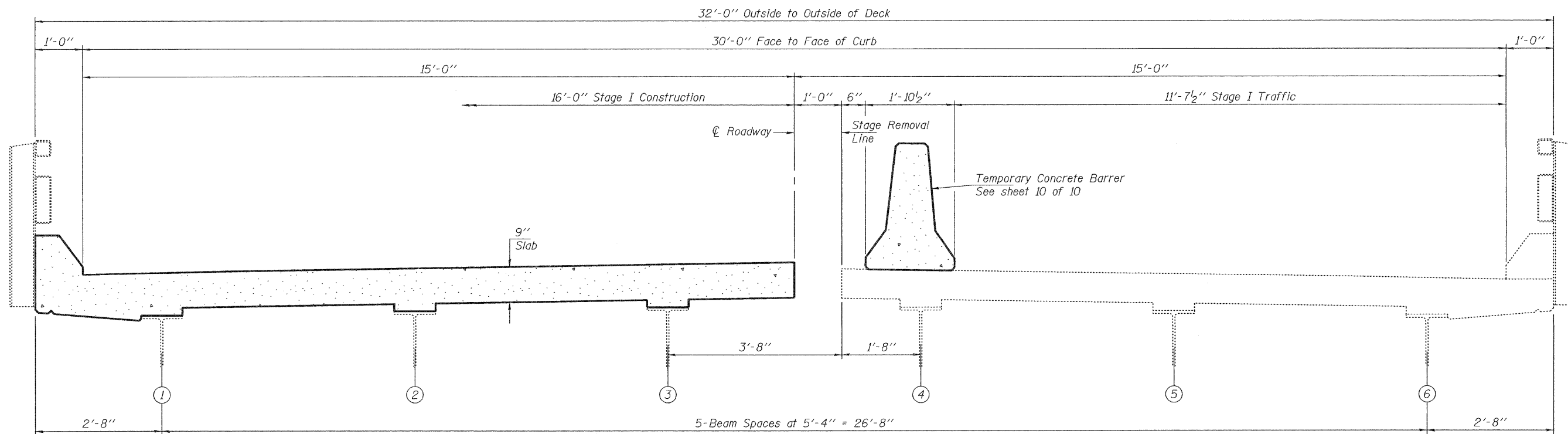

STAGE I CROSS-SECTION
(Looking South)

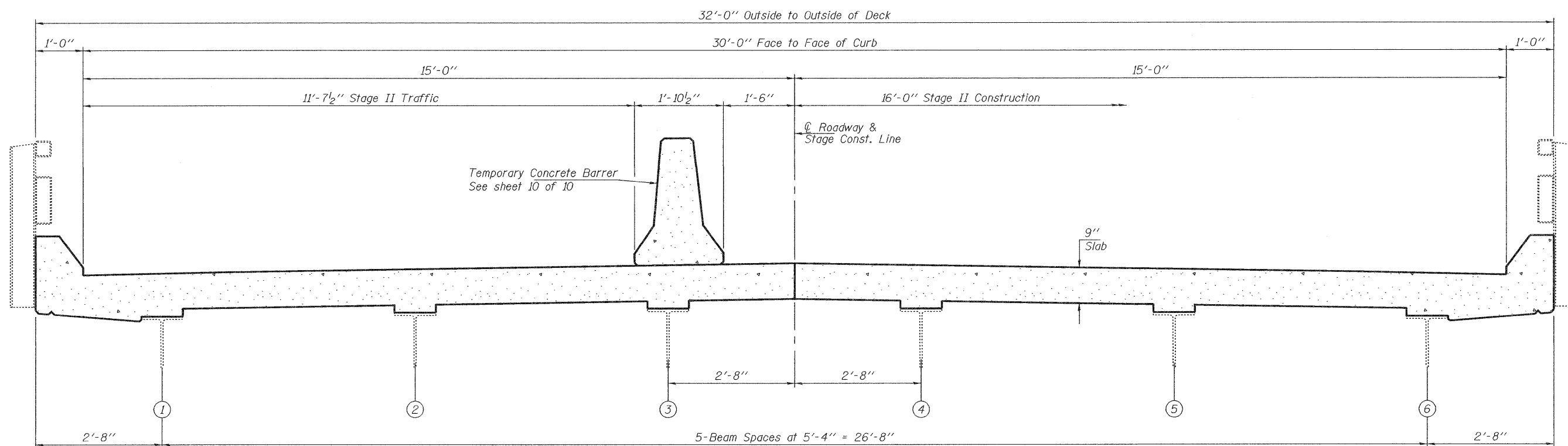

STAGE II CROSS-SECTION
(Looking South)

DESIGNED - ADY	EXAMINED - <i>Joanne F. Jeffers</i> ACTING ENGINEER OF STRUCTURAL SERVICES	DATE - MARCH 4, 2011	STATE OF ILLINOIS DEPARTMENT OF TRANSPORTATION	STAGE CONSTRUCTION DETAILS SN 015-0036	F.A.S. RTE. - 677	SECTION - (15-2, 15-1, 15, 11)RS-1	COUNTY - COLES	TOTAL SHEETS - 40	SHEET NO. - 40	
CHECKED - IJL	PASSED - <i>Carl Brown</i> ACTING ENGINEER OF BRIDGES AND STRUCTURES				SHEET NO. 2 OF 10 SHEETS		CONTRACT NO. 74507 ILLINOIS FED. AID PROJECT			
DRAWN - Kyle M. Steffen										
CHECKED - ADY IJL										

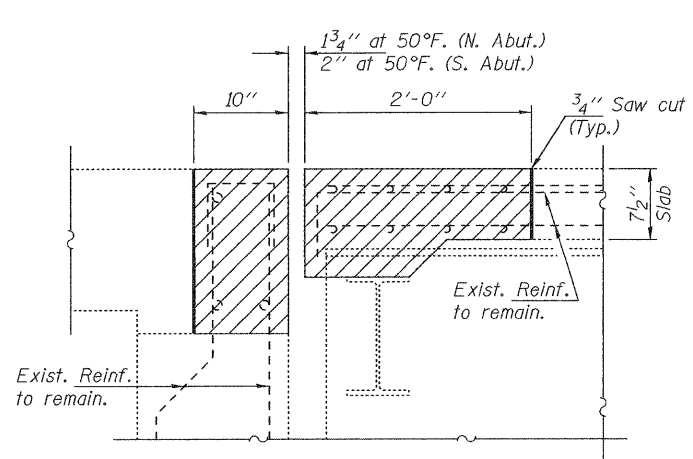

SECTION A-A

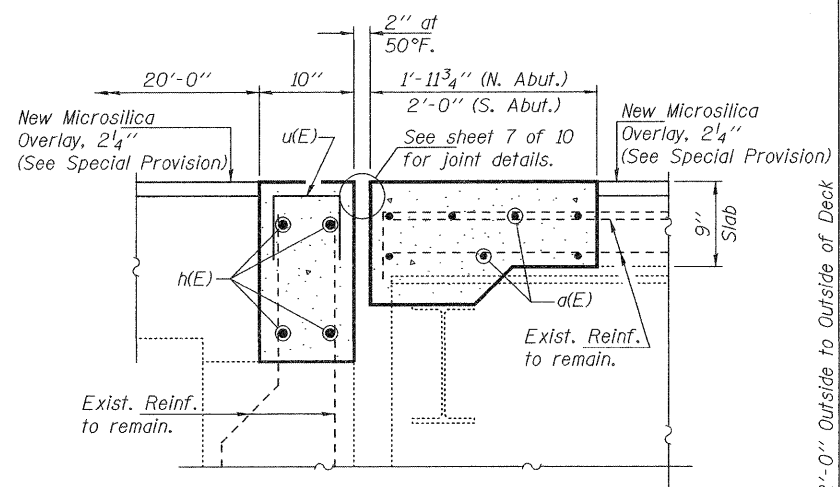

SECTION B-B

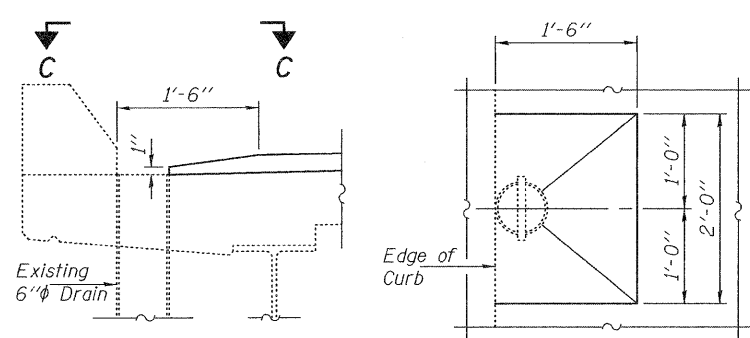

SECTION THRU CURB AT DRAIN EXTENSIONS

VIEW C-C

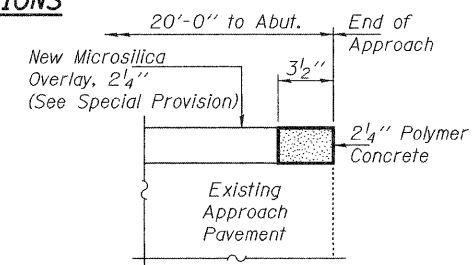

DETAIL "A"

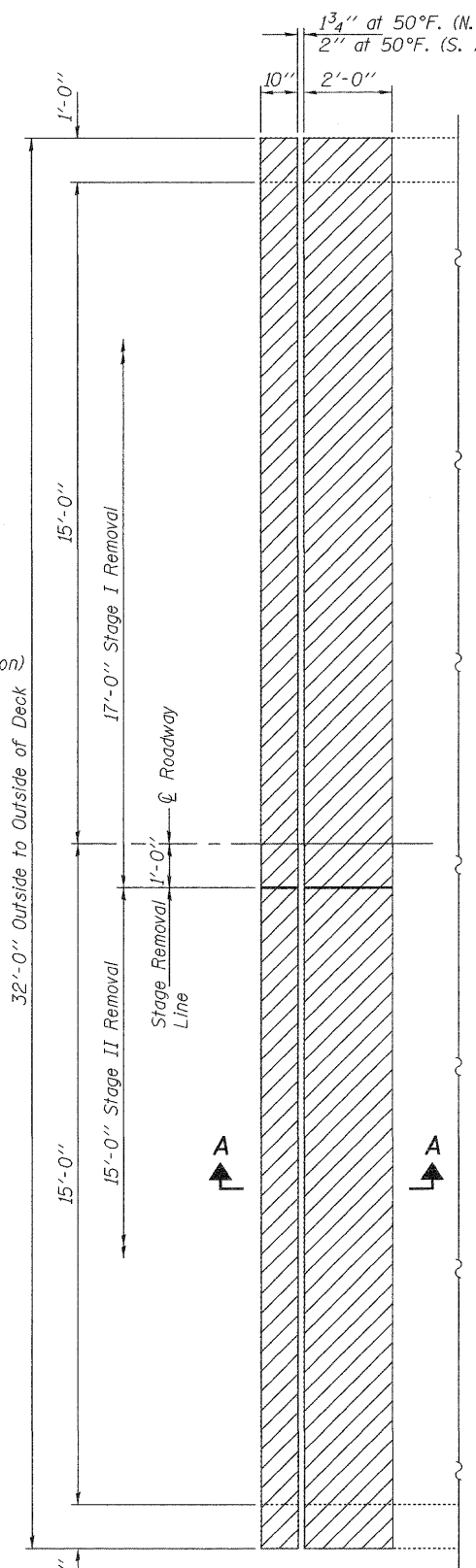

REMOVAL PLAN AT ABUTMENTS

North Abutment shown, South Abutment similar by 180° rotation except as noted.

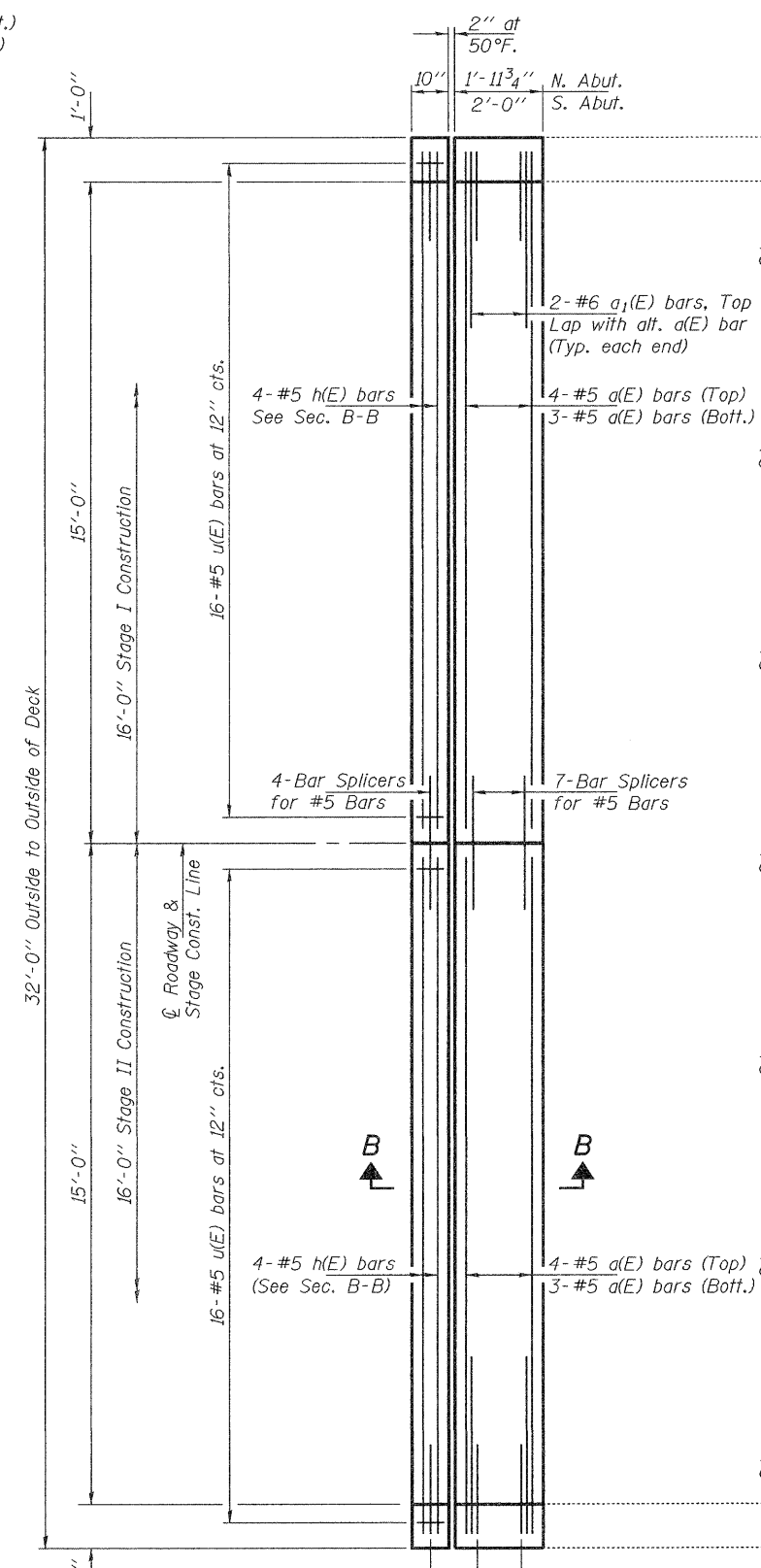

CONCRETE PLAN AT ABUTMENTS

North Abutment shown, South Abutment similar by 180° rotation except as noted.

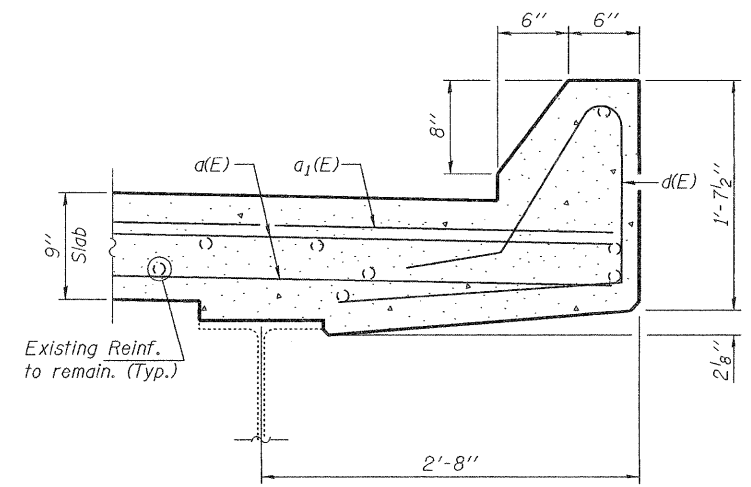

SECTION THRU CURB

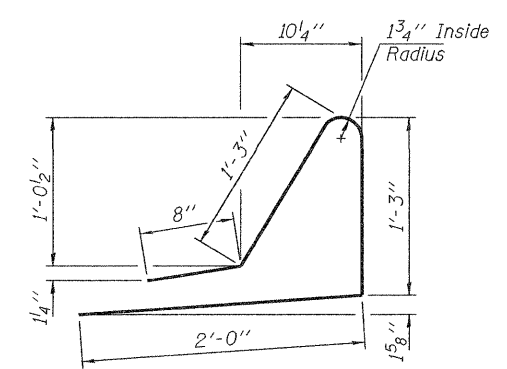

d(E) BARS

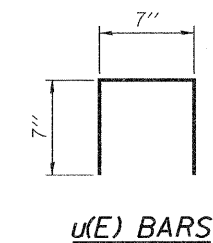

u(E) BARS

BILL OF MATERIAL (PER ABUTMENT)

Bar	No.	Size	Length	Shape
a(E)	14	#5	15'-8"	—
a ₁ (E)	4	#6	4'-0"	—
d(E)	8	#5	5'-2"	△
h(E)	8	#5	15'-8"	—
u(E)	32	#5	1'-9"	□
Concrete Removal			Cu. Yd.	3.5
Concrete Superstructure			Cu. Yd.	3.9
Bar Splicers			Each	11
Reinforcement Bars, Epoxy Coated			Pound	490

DESIGNED - ADY
 CHECKED - IJL
 DRAWN - Kyle M. Steffen
 CHECKED - ADY IJL

EXAMINED
 PASSED
 ACTING ENGINEER OF STRUCTURAL SERVICES
 ACTING ENGINEER OF BRIDGES AND STRUCTURES

DATE - MARCH 4, 2011

**STATE OF ILLINOIS
 DEPARTMENT OF TRANSPORTATION**

**JOINT REMOVAL & REPLACEMENT DETAILS
 SN 015-0036**

SHEET NO. 3 OF 10 SHEETS

F.A.S. RTE. 677	SECTION (15-2, 15-1, 15, 11)RS-1	COUNTY COLES	TOTAL SHEETS 63	SHEET NO. 41
			CONTRACT NO. 74507	
ILLINOIS FED. AID PROJECT				

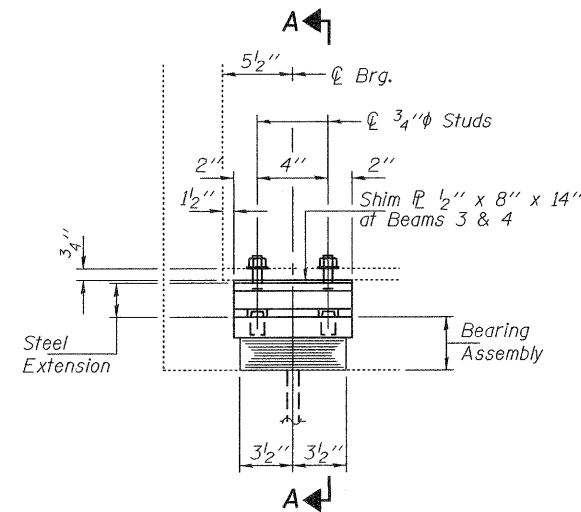

ELEVATION AT ABUTMENT

TYPE I ELASTOMERIC EXP. BRG.

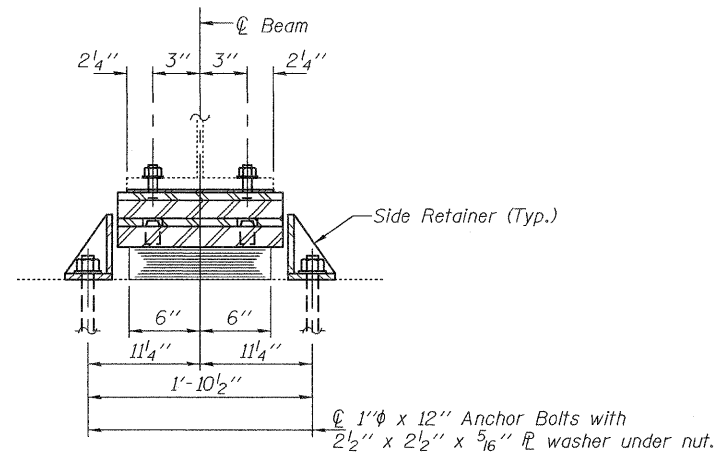

SECTION A-A

1" ϕ x 12" Anchor Bolts with 2 1/2" x 2 1/2" x 5/16" ϕ washer under nut.

BEAM REACTIONS

RP	(K)	15.3
Rt	(K)	28.7
Imp.	(K)	7.6
R (Total)	(K)	51.6

Notes:
 Diaphragm removal and reinstallation may be required to facilitate drilling holes. Cost included with Furnishing and Erecting Structural Steel.
 New steel extensions, shim plates and connection bolts are included with Furnishing and Erecting Structural Steel.
 Prior to ordering any material, the Contractor shall verify in the field all bearing height and shim thickness dimensions. Min. jack capacity = 30 Tons.
 Anchor bolts shall be ASTM F1554 all-thread (or an Engineer-approved alternate material) of the grade(s) and diameter(s) specified. ASTM A307 Grade C anchor bolts may be used in lieu of ASTM F1554 Grade 36 (Fy=36ksi). The corresponding specified grade of AASHTO M314 anchor bolts may be used in lieu of ASTM F1554.
 Drilled and set anchor bolts shall be installed according to Article 521.06 of the Standard Specifications.
 Side retainers shall be included in the cost of Elastomeric Bearing Assembly, Type I.

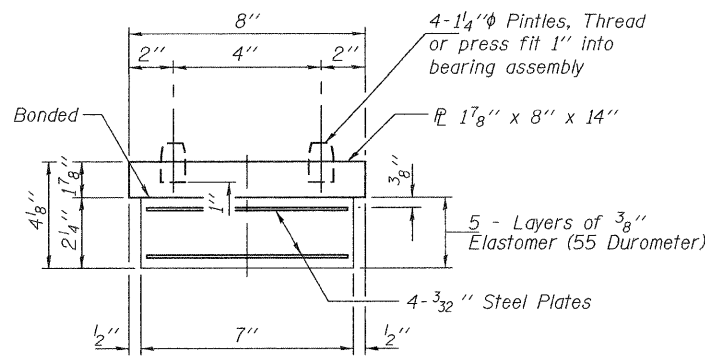

BEARING ASSEMBLY

Note:
 Shim plates shall not be placed under Bearing Assembly.

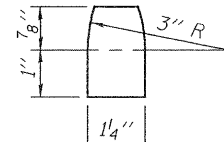

PINTLE

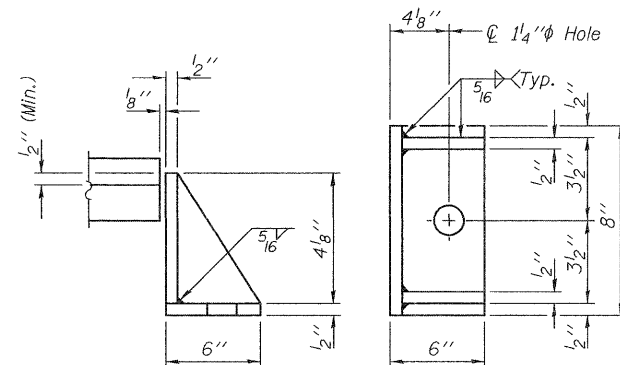

SIDE RETAINER

Equivalent rolled angle with stiffeners will be allowed in lieu of welded plates.

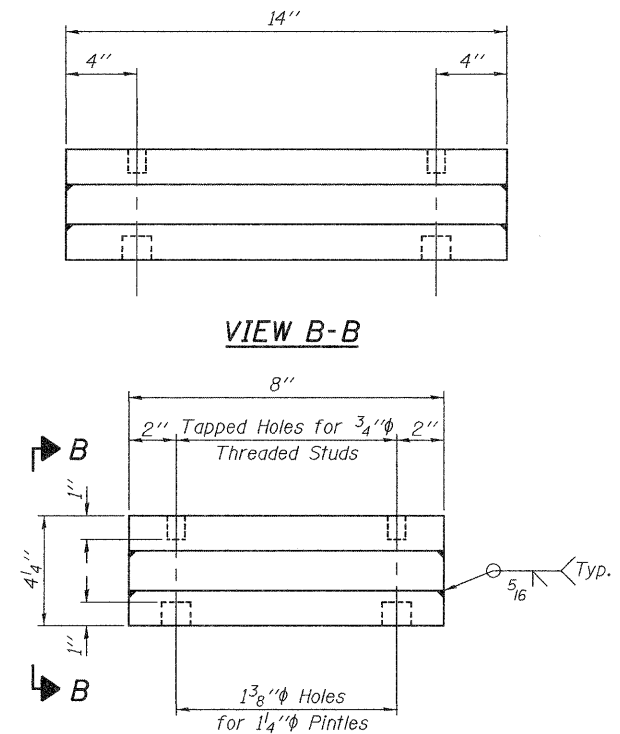

VIEW B-B

STEEL EXTENSION DETAIL

One or more ϕ 's may be used. Number of individual ϕ 's to be determined by fabricator. Minimum thickness of individual ϕ 's shall be 1".

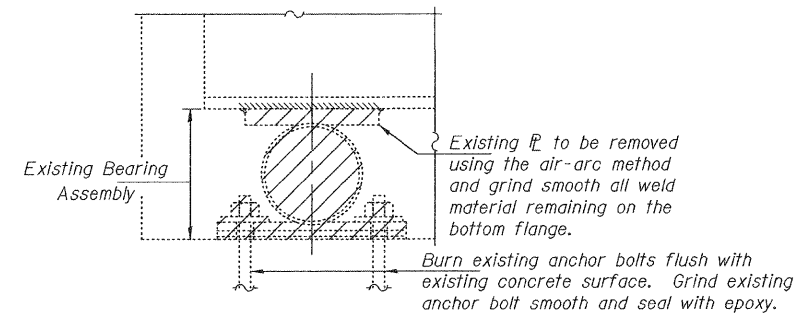

EXISTING BEARING REMOVAL DETAIL

Cost included with Jack and Remove Existing Bearings.

BILL OF MATERIAL

Item	Unit	Total
Elastomeric Bearing Assembly, Type I	Each	6
Jack and Remove Existing Bearings	Each	6
Furnishing and Erecting Structural Steel	Pound	870
Anchor Bolts 1" ϕ	Each	12

DESIGNED - ADY	EXAMINED	DATE - MARCH 4, 2011
CHECKED - IJL	PASSED	
DRAWN - Kyle M. Steffen		
CHECKED - ADY IJL		

STATE OF ILLINOIS
 DEPARTMENT OF TRANSPORTATION

BEARING REPLACEMENT DETAILS AT NORTH ABUTMENT
 SN 015-0036

SHEET NO. 5 OF 10 SHEETS

F.A.S. RTE. 677	SECTION (15-2, 15-1, 15, 11)RS-1	COUNTY COLES	TOTAL SHEETS 63	SHEET NO. 43
				CONTRACT NO. 74507
ILLINOIS FED. AID PROJECT				

BEAM REACTIONS

R ₁	(K)	15.3
R ₂	(K)	28.7
Imp.	(K)	7.6
R (Total)	(K)	51.6

Notes:
 Diaphragm removal and installation may be required to facilitate drilling holes. Cost included with Furnishing and Erecting Structural Steel.
 New steel extensions, shim plates and connection bolts are included with Furnishing and Erecting Structural Steel.
 Prior to ordering any material, the Contractor shall verify in the field all bearing height and shim thickness dimensions. Min. jack capacity = 30 Tons.
 Anchor bolts shall be ASTM F1554 all-thread (or an Engineer-approved alternate material) of the grade(s) and diameter(s) specified. ASTM A307 Grade C anchor bolts may be used in lieu of ASTM F1554 Grade 36 (Fy=36ksi). The corresponding specified grade of AASHTO M314 anchor bolts may be used in lieu of ASTM F1554.
 Anchor bolts for Type II bearings shall be placed in holes drilled through the bottom bearing plate after members are in place. Side retainers shall be placed after bolts are installed.
 Drilled and set anchor bolts shall be installed according to Article 521.06 of the Standard Specifications.
 Side retainers shall be included in the cost of Elastomeric Bearing Assembly, Type II.
 The 1/8" PTFE sheet shall be bonded directly to the top steel plate with a two-component, medium viscosity epoxy resin, conforming to the requirements of the Federal Specification MMM-A-134, Type I. The bond agent shall be applied on the full area of the contact surfaces.
 Bonding of 1/8" PTFE sheet during vulcanizing process will be permitted provided the process and method of adjusting assembly height is approved by the Engineer.

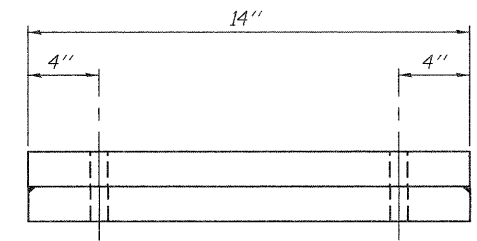

VIEW B-B

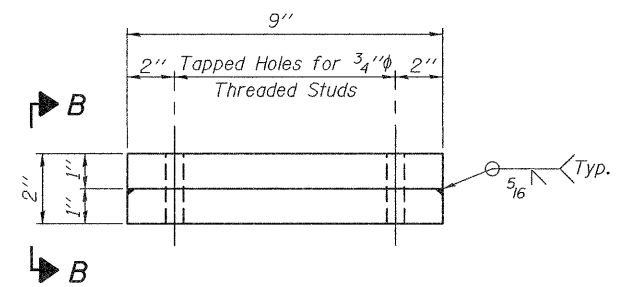

STEEL EXTENSION DETAIL

One or more R's may be used. Number of individual R's to be determined by fabricator. Minimum thickness of individual R's shall be 1".

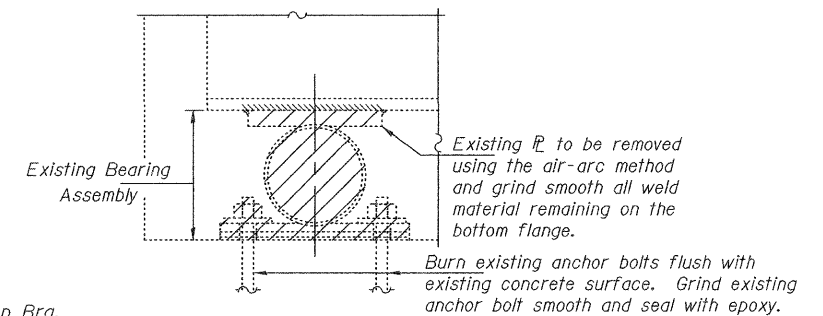

EXISTING BEARING REMOVAL DETAIL

Cost included with Jack and Remove Existing Bearings.

BILL OF MATERIAL

Item	Unit	Total
Elastomeric Bearing Assembly, Type II	Each	6
Jack and Remove Existing Bearings	Each	6
Furnishing and Erecting Structural Steel	Pound	470
Anchor Bolts 1"φ	Each	12

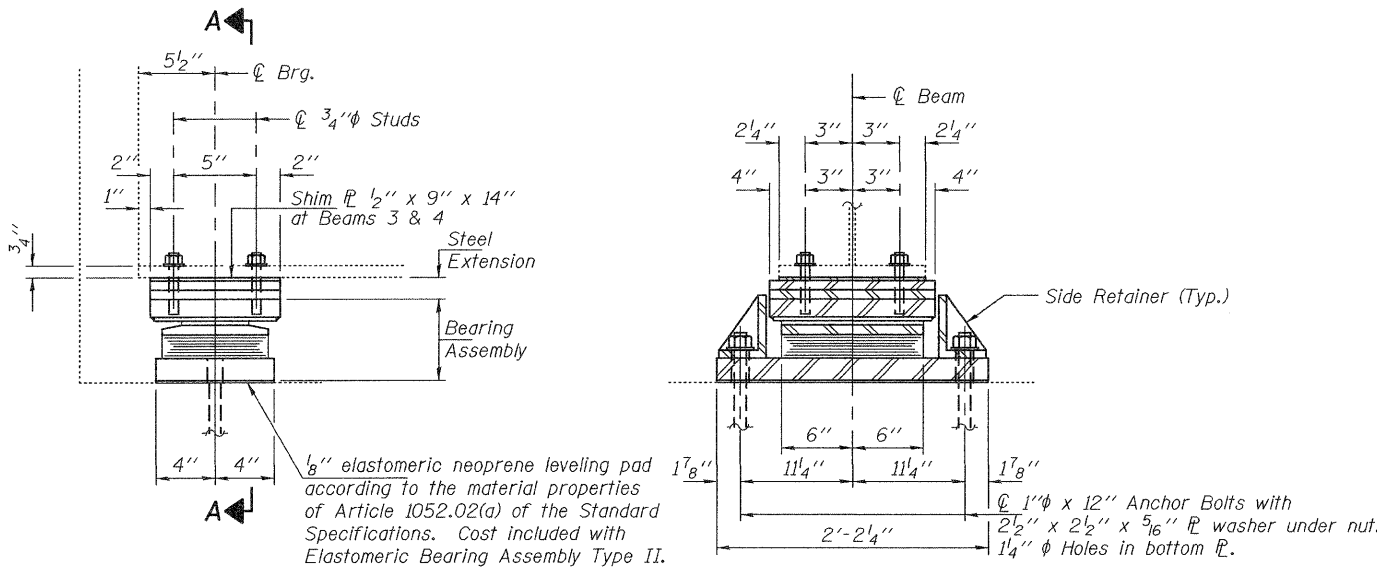

ELEVATION AT ABUTMENT

SECTION A-A

TYPE II TFE ELASTOMERIC EXP. BRG.

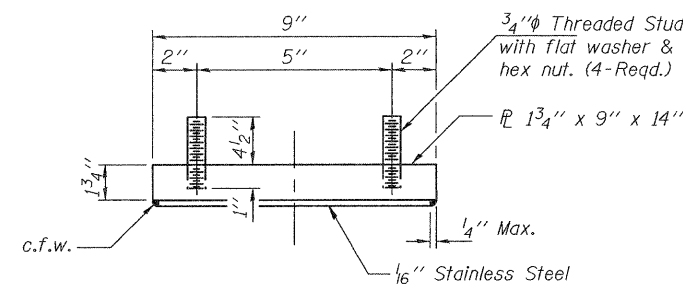

TOP BEARING ASSEMBLY

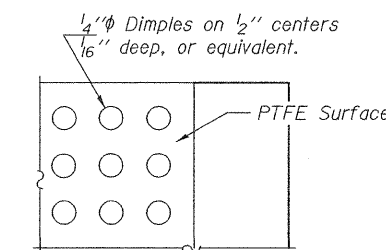

PLAN-PTFE SURFACE

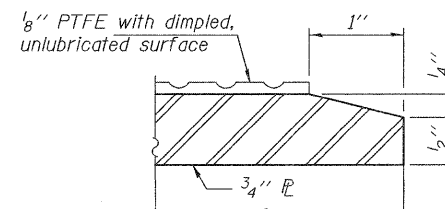

SECTION THRU PTFE

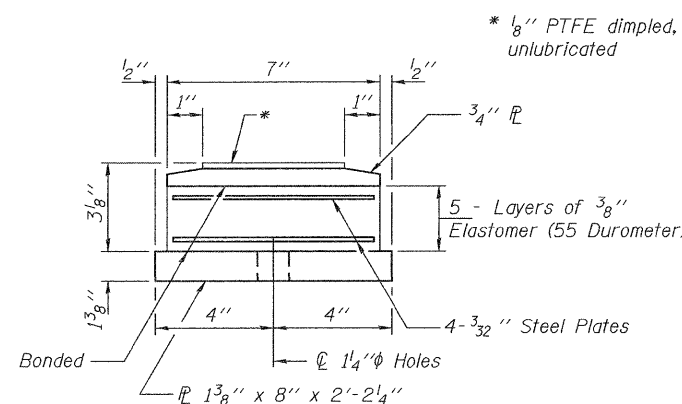

BOTTOM BEARING ASSEMBLY

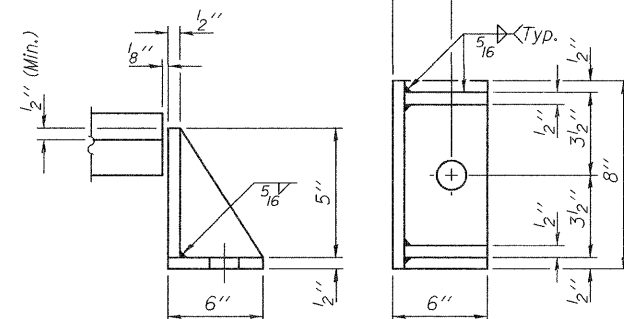

SIDE RETAINER

Equivalent rolled angle with stiffeners will be allowed in lieu of welded plates.

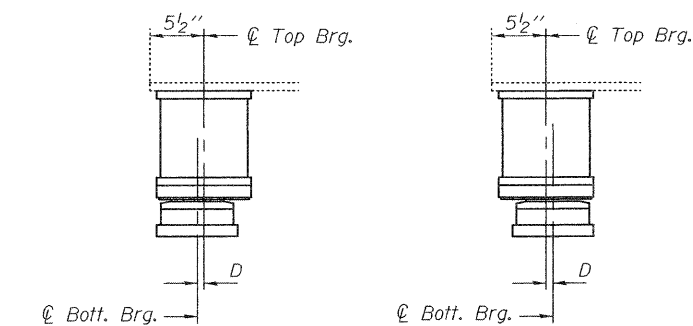

BELOW 50° F. (Move bott. brg. away from fixed brg.) ABOVE 50° F. (Move bott. brg. toward fixed brg.)

SETTING ANCHOR BOLTS AT EXP. BRG.

D = 1/8" per each 100' of expansion for every 15° temp. change from the normal temp. of 50°F.

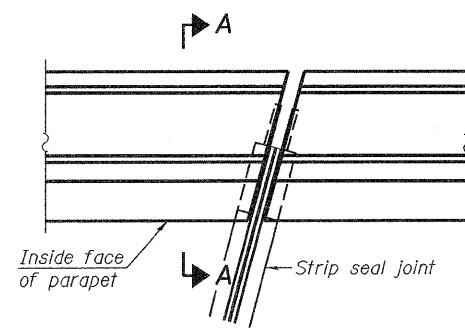

PLAN
(For skews $\leq 30^\circ$)

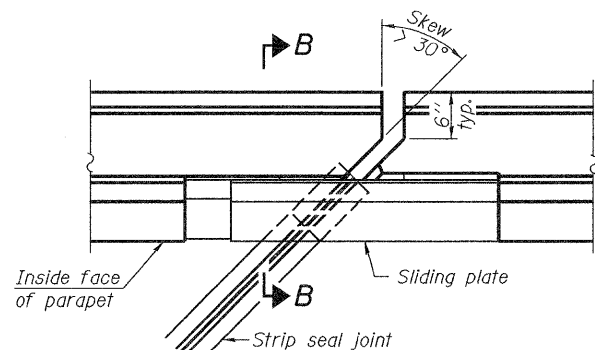

PLAN
(For skews $> 30^\circ$)
Showing point block

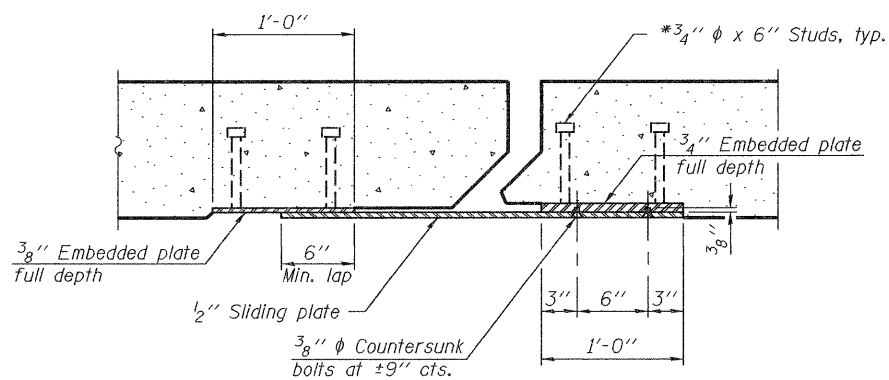

SECTION C-C

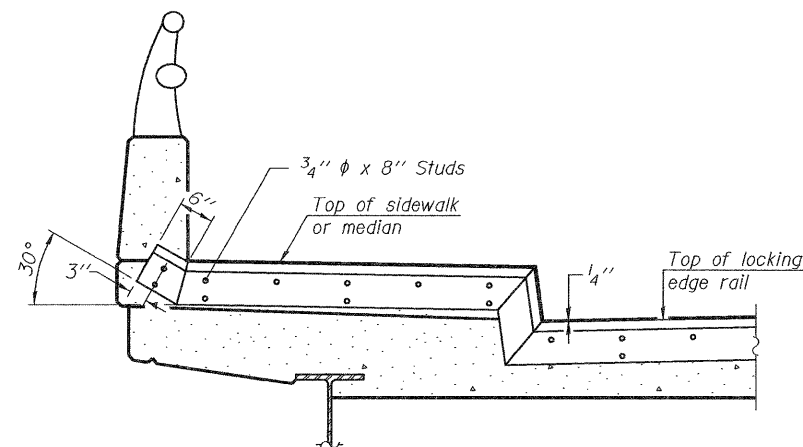

TYPICAL END TREATMENT AT SIDEWALK OR MEDIAN

Shorter plates with a single row of studs at 12" cts. may be necessary on medians which are shallower than 9". See manufacturer's recommendation.

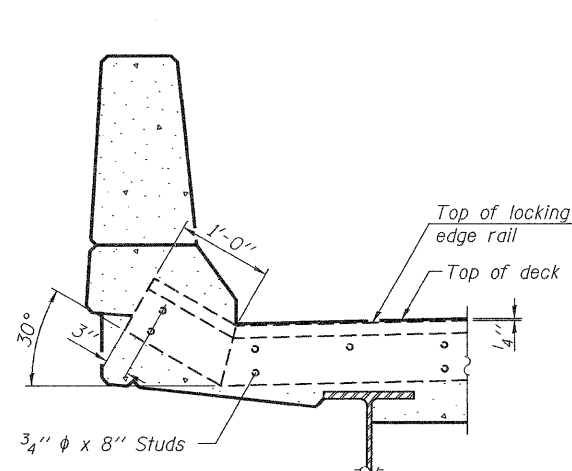

SECTION A-A

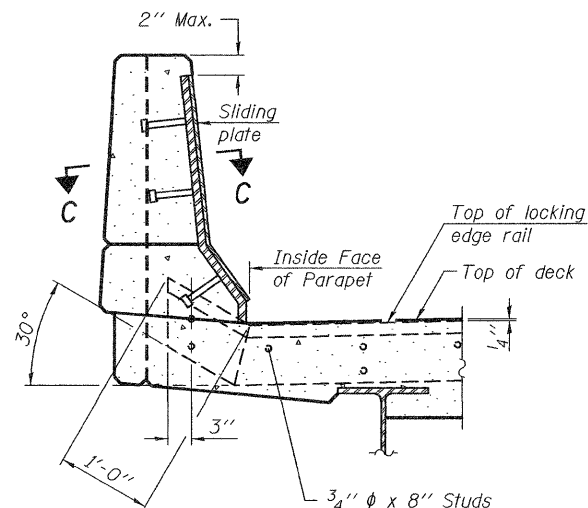

SECTION B-B

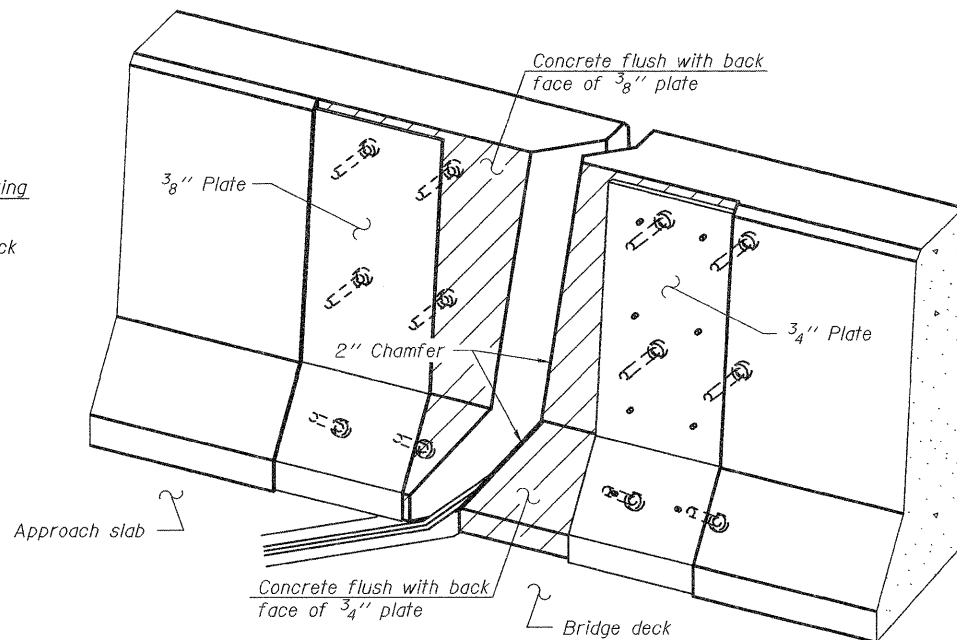

TRIMETRIC VIEW
(Showing back plates only)

Notes:

The strip seal shall be made continuous and shall have a minimum thickness of 1/4". The configuration of the strip seal shall match the configuration of the Locking Edge Rails. Open or "webbed" strip seal gland configurations are not permitted. The gland shall be sized for a maximum rated movement of 4 inches.

The Locking Edge Rails depicted are conceptual only, except for the minimum dimensions shown. The actual configuration of the Locking Edge Rails and matching strip seal may vary from manufacturer to manufacturer. Flanged edge rails will not be allowed. Locking Edge Rails may be spliced at slope discontinuities.

The manufacturer's recommended installation methods shall be followed.

The joint opening and deck dimensions detailed on the superstructure are based on a rolled rail expansion joint. If the Contractor elects to use the welded rail expansion joint, the opening and deck dimensions shall be modified according to the dimensions detailed on this sheet. Required modifications shall be made at no additional cost to the State.

All steel components shall be galvanized after fabrication according to Article 520.03 of the Standard Specifications.

Maximum space between rail segments at stage lines shall be 3/16", sealed with a suitable sealant.

Parapet plates and anchorage studs for skews $> 30^\circ$ included in the cost of Preformed Joint Strip Seal.

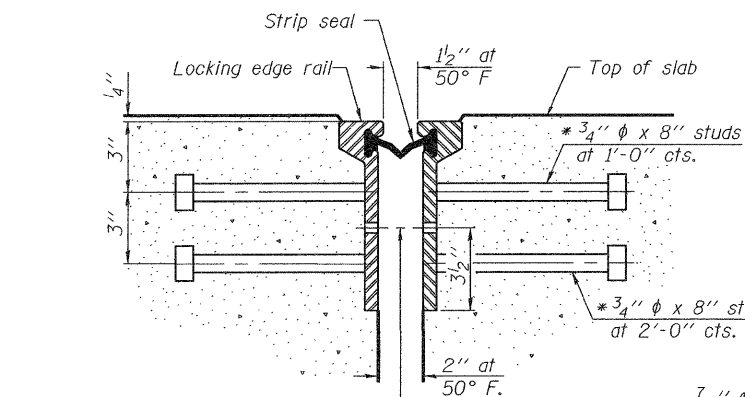

SECTION THRU ROLLED RAIL JOINT

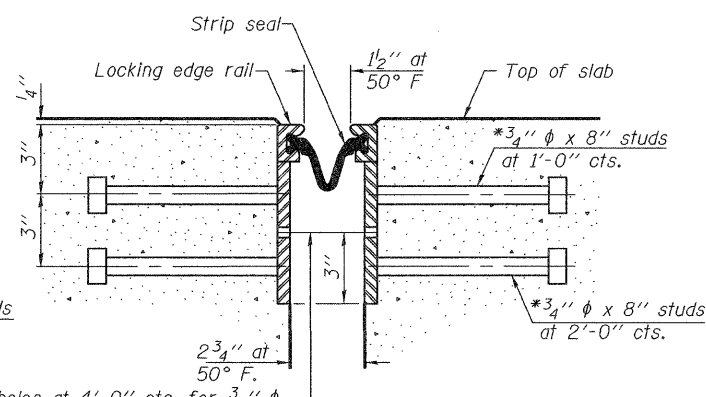

SECTION THRU WELDED RAIL JOINT

7/16" ϕ holes at 4'-0" cts. for 3/8" ϕ bolts. All bolts shall be burned, sawed, or chipped off flush with the plates after forms are removed, typ.

7/16" ϕ holes at 4'-0" cts. for 3/8" ϕ bolts. All bolts shall be burned, sawed, or chipped off flush with the plates after forms are removed, typ.

ROLLED EXTRUDED RAIL

WELDED RAIL

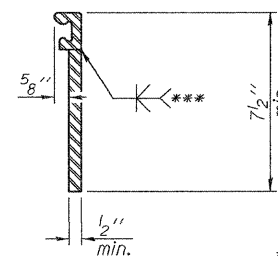
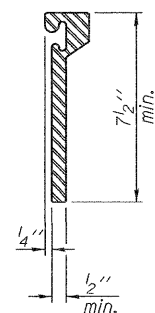

*** Back gouge not required if complete joint penetration is verified by mock-up.

LOCKING EDGE RAIL SPLICE

The inside of the locking edge rail groove shall be free of weld residue.

Rolled rail shown, welded rail similar.

LOCKING EDGE RAILS

BILL OF MATERIAL

Item	Unit	Total
Preformed Joint Strip Seal	Foot	64

EJ-SSJ

7-1-10

DESIGNED - ADY	CHECKED - IJL	DRAWN - Kyle M. Steffen	CHECKED - ADY IJL
----------------	---------------	-------------------------	-------------------

EXAMINED	DATE - MARCH 4, 2011
PASSED	

DATE - MARCH 4, 2011

STATE OF ILLINOIS
DEPARTMENT OF TRANSPORTATION

PREFORMED JOINT STRIP SEAL DETAILS
SN 015-0036

SHEET NO. 7 OF 10 SHEETS

F.A.S. RTE. 677	SECTION (15-2, 15-1, 15, 11)RS-1	COUNTY COLES	TOTAL SHEETS 63	SHEET NO. 45
				CONTRACT NO. 74507
ILLINOIS FED. AID PROJECT				

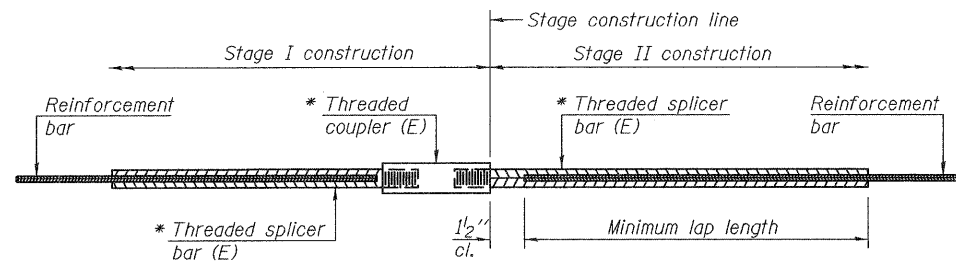

STANDARD BAR SPLICER ASSEMBLY

Minimum Lap Lengths					
Bar size to be spliced	Table 1	Table 2	Table 3	Table 4	Table 5
3, 4	1'-5"	1'-11"	2'-1"	2'-4"	2'-3"
5	1'-9"	2'-5"	2'-7"	2'-11"	2'-10"
6	2'-1"	2'-11"	3'-1"	3'-6"	3'-4"
7	2'-9"	3'-10"	4'-2"	4'-8"	4'-6"
8	3'-8"	5'-1"	5'-5"	6'-2"	5'-10"
9	4'-7"	6'-5"	6'-10"	7'-9"	7'-5"

- Table 1: Black bar, 0.8 Class C
- Table 2: Black bar, Top bar lap, 0.8 Class C
- Table 3: Epoxy bar, 0.8 Class C
- Table 4: Epoxy bar, Top bar lap, 0.8 Class C
- Table 5: Epoxy bar, Top bar lap, Class B

Threaded splicer bar length = min. lap length + 1 1/2" + thread length

* Epoxy not required on Bar Splicer Assembly components used in conjunction with black bars.

Location	Bar size	No. assemblies required	Table for minimum lap length
North Abutment	#5	11	3
South Abutment	#5	11	3

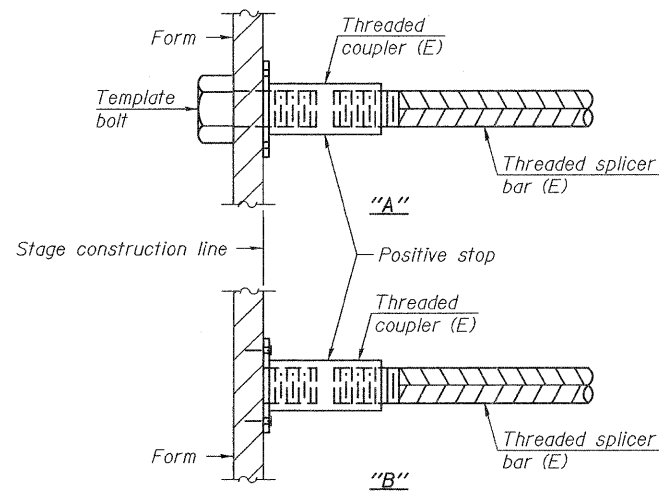

INSTALLATION AND SETTING METHODS

"A" : Set bar splicer assembly by means of a template bolt.
 "B" : Set bar splicer assembly by nailing to wood forms or cementing to steel forms.
 (E) : Indicates epoxy coating.

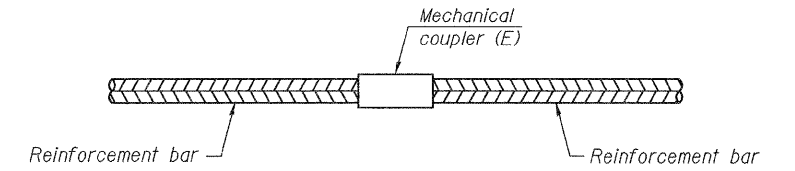

STANDARD MECHANICAL SPLICER

Location	Bar size	No. assemblies required

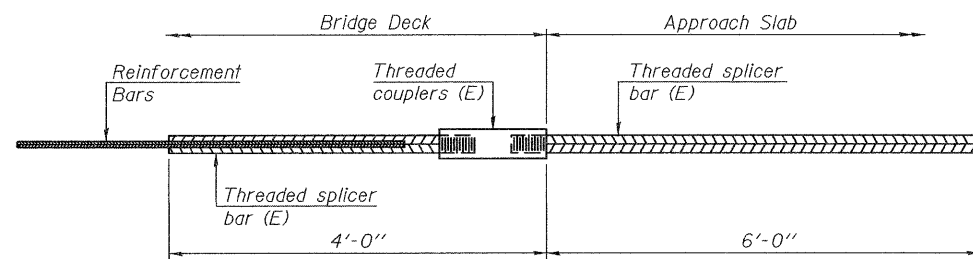

BAR SPLICER ASSEMBLY FOR #5 BAR ON INTEGRAL OR SEMI-INTEGRAL ABUTMENTS

No. required =

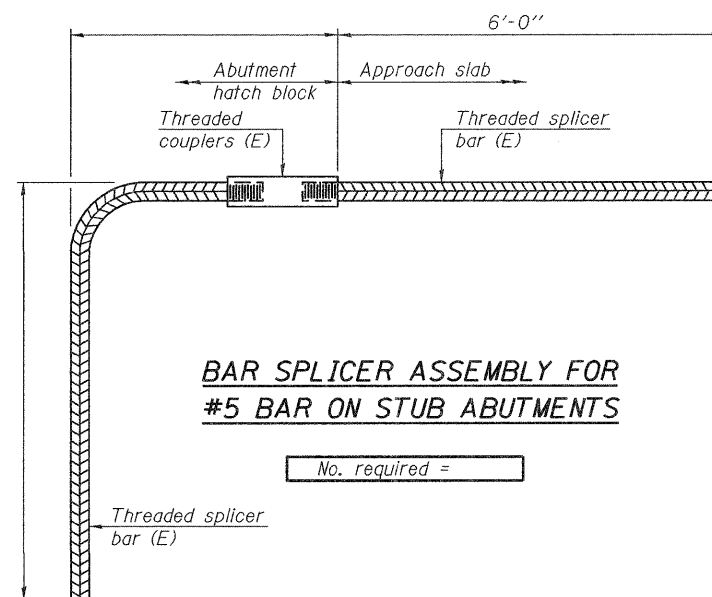

BAR SPLICER ASSEMBLY FOR #5 BAR ON STUB ABUTMENTS

No. required =

NOTES

Splicer bars shall be deformed with threaded ends and have a minimum 60 ksi yield strength.
 All reinforcement shall be lapped and tied to the splicer bars.
 Bar splicer assemblies shall be epoxy coated according to the requirements for reinforcement bars. See Section 508 of the Standard Specifications.
 See special provision for Mechanical Splicers.
 See approved list of bar splicer assemblies and mechanical splicers for alternatives.

BSD-1

7-1-10

DESIGNED - ADY	EXAMINED - <i>Joanne F. Jelliffe</i>	DATE - MARCH 4, 2011
CHECKED - IJL	ACTING ENGINEER OF STRUCTURAL SERVICES	
DRAWN - Kyle M. Steffen	PASSED - <i>Carl Hoover</i>	
CHECKED - ADY IJL	ACTING ENGINEER OF BRIDGES AND STRUCTURES	

STATE OF ILLINOIS
 DEPARTMENT OF TRANSPORTATION

BAR SPLICER ASSEMBLY AND MECHANICAL SPLICER DETAILS
 SN 015-0036

SHEET NO. 8 OF 10 SHEETS

F.A.S. RTE. 677	SECTION (15-2, 15-1, 15, 11)RS-1	COUNTY COLES	TOTAL SHEETS 63	SHEET NO. 46
CONTRACT NO. 74507			ILLINOIS FED. AID PROJECT	

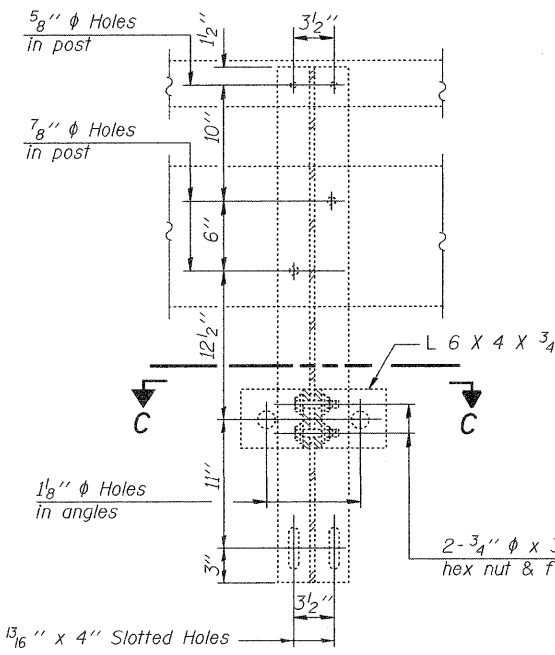

SECTION B-B

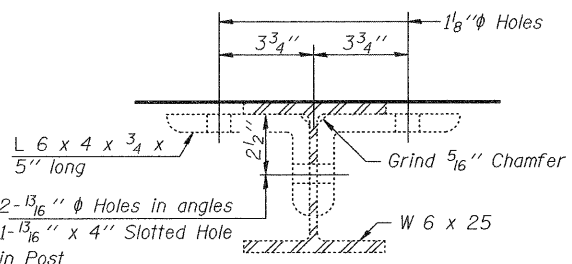

SECTION C-C

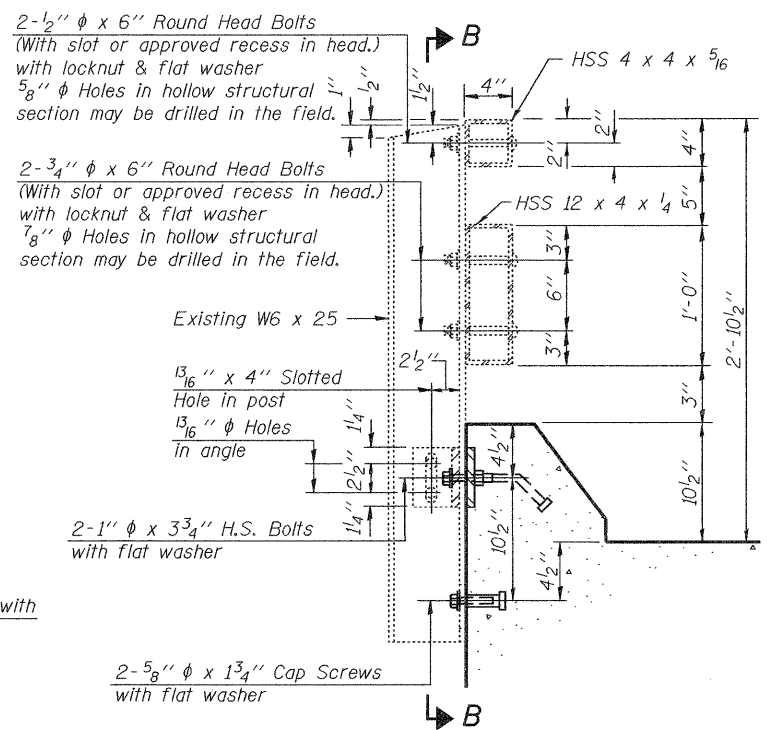

SECTION AT RAIL POST

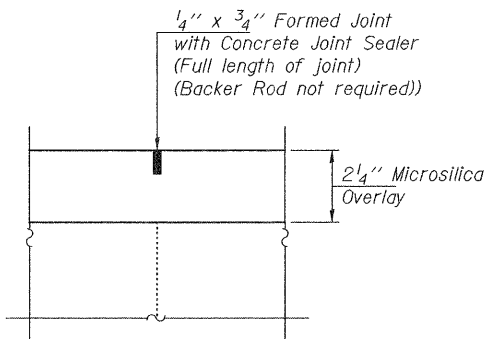

DETAIL "B"

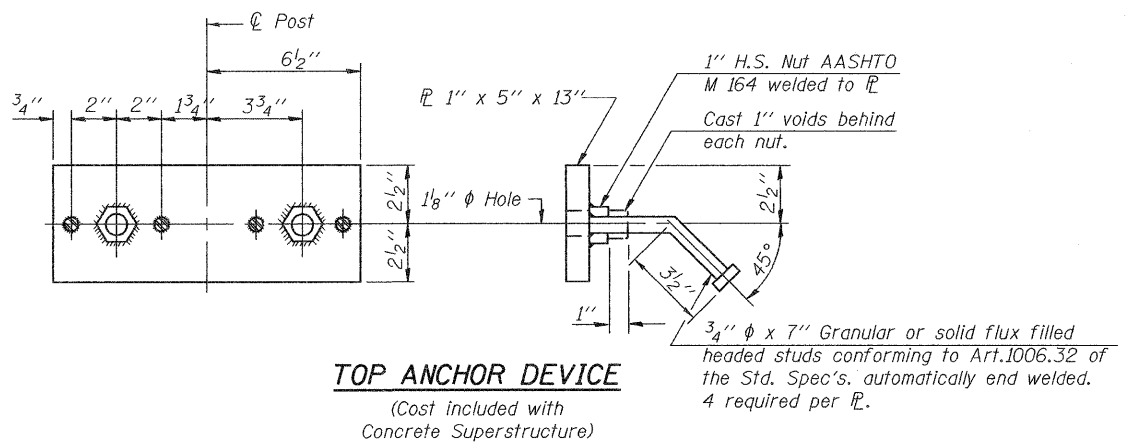

TOP ANCHOR DEVICE
(Cost included with Concrete Superstructure)

* Threaded areas shall be plugged or blocked off during casting of beam.

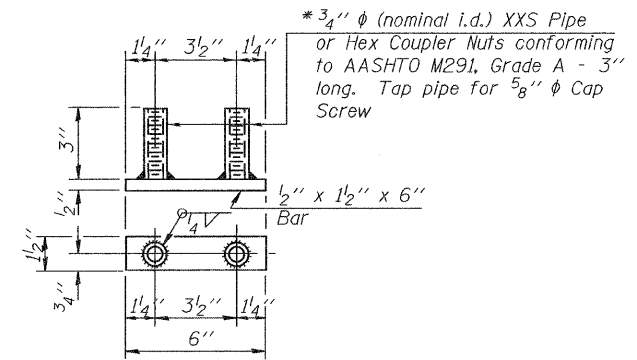

BOTTOM ANCHOR DEVICE
(Cost included with Concrete Superstructure)

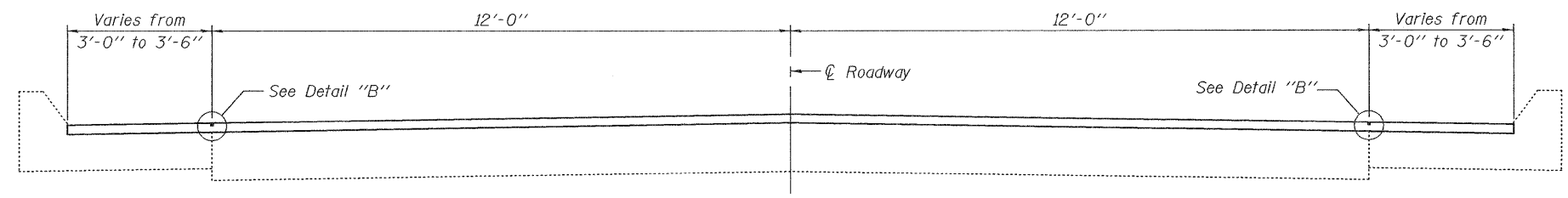

APPROACH CROSS-SECTION

DESIGNED - ADY	EXAMINED - <i>Joanne F. Jelliff</i>	DATE - MARCH 4, 2011	STATE OF ILLINOIS DEPARTMENT OF TRANSPORTATION		RAIL POST DETAILS & APPROACH CROSS-SECTION SN 015-0036		F.A.S. RTE. 677	SECTION (15-2, 15-1, 15, 11)RS-1	COUNTY COLES	TOTAL SHEETS 63	SHEET NO. 47
CHECKED - IJL	PASSED - <i>Carl Boyer</i>						SHEET NO. 9 OF 10 SHEETS		ILLINOIS FED. AID PROJECT		CONTRACT NO. 74507

When "A" is 3'-6" or less, the temporary concrete barrier shall be anchored to the new slab according to Detail I or Detail II. No anchorage is required when "A" is greater than 3'-6".

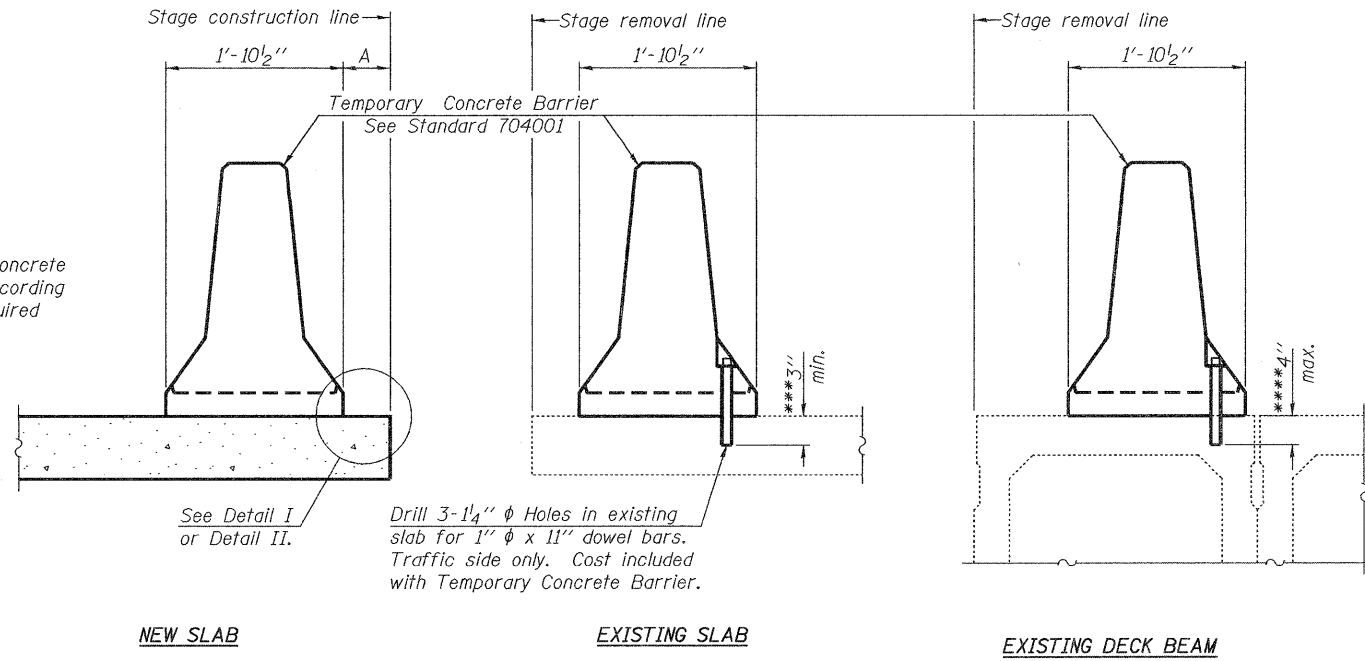

SECTIONS THRU SLAB OR DECK BEAM

NOTES

Detail I - With Bar Splicer or Couplers:
Connect one (1) 1" x 7" x "W" steel PL to the top layer of couplers with 2-5/8" φ bolts screwed to coupler at approximate C of each barrier panel.

Detail II - With Extended Reinforcement Bars:
Connect one (1) 1" x 7" x "W" steel PL to the concrete slab or concrete wearing surface with 2-5/8" φ Expansion Anchors or cast in place inserts spaced between the top layer of reinforcement at approximate C of each barrier panel.

Cost of anchorage is included with Temporary Concrete Barrier. The 1" x 7" x "W" plate shall not be removed until stage II construction forms and all reinforcement bars are in place and the concrete is ready to be placed.

*** Dimension shown is minimum required embedment into concrete. If hot-mix asphalt wearing surface is present, minimum embedment shall be in addition to wearing surface depth.

**** If existing deck beam is to remain in place after stage construction, embedment shall only be into wearing surface and not into existing deck beam concrete.

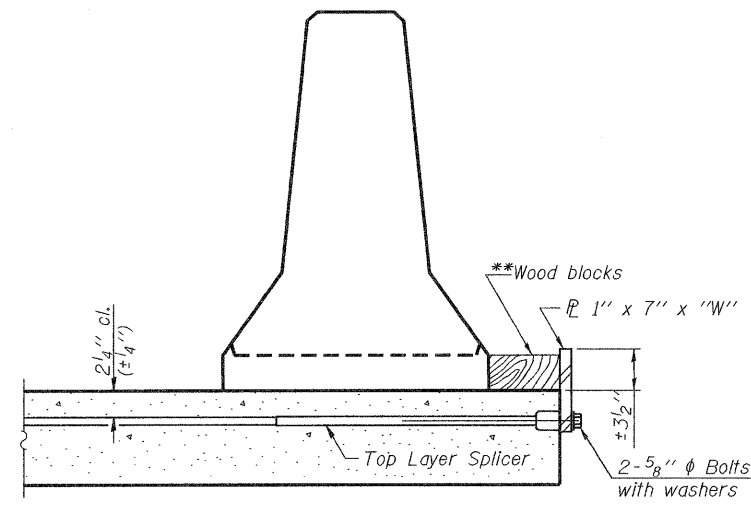

DETAIL I

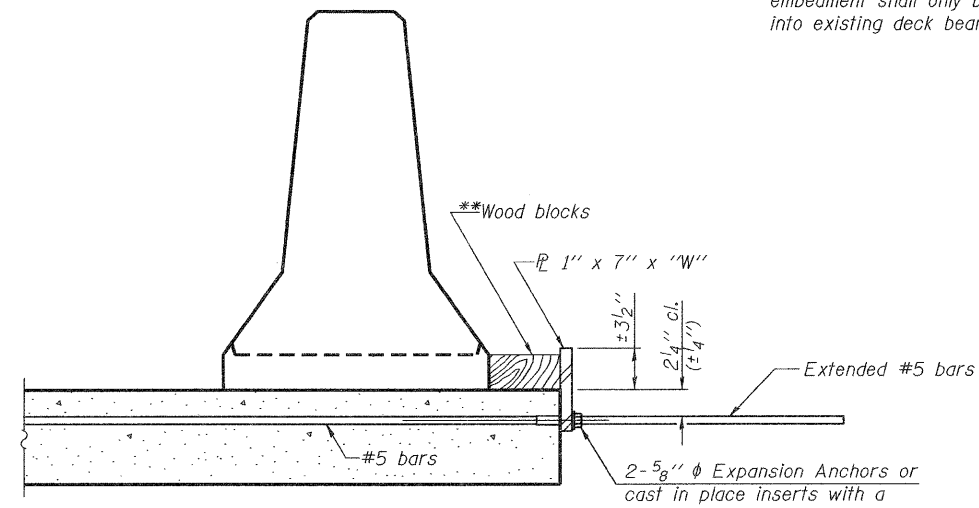

DETAIL II

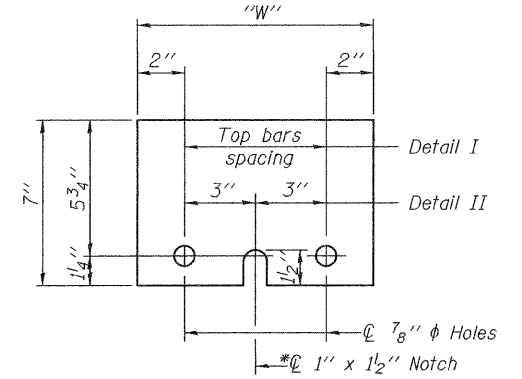

STEEL RETAINER PL 1" x 7" x "W"

* Required only with Detail II

** Wood blocks may be omitted when required to provide minimum stage traffic lane width. When the wood blocks are omitted, the concrete barrier shall be in direct contact with the steel retainer plate.

"W" = Top bars spacing + 4"

R-27

7-1-10

DESIGNED - ADY	EXAMINED - <i>Joanne F. Jelliff</i> ACTING ENGINEER OF STRUCTURAL SERVICES	DATE - MARCH 4, 2011	STATE OF ILLINOIS DEPARTMENT OF TRANSPORTATION	TEMPORARY CONCRETE BARRIER FOR STAGE CONSTRUCTION SN 015-0036	F.A.S. RTE. 677	SECTION (15-2, 15-1, 15, 11)RS-1	COUNTY COLES	TOTAL SHEETS 63	SHEET NO. 48
CHECKED - IJL	PASSED - <i>Carl Meyer</i> ACTING ENGINEER OF BRIDGES AND STRUCTURES				SHEET NO. 10 OF 10 SHEETS		ILLINOIS FED. AID PROJECT CONTRACT NO. 74507		
DRAWN - Kyle M. Steffen									
CHECKED - ADY IJL									

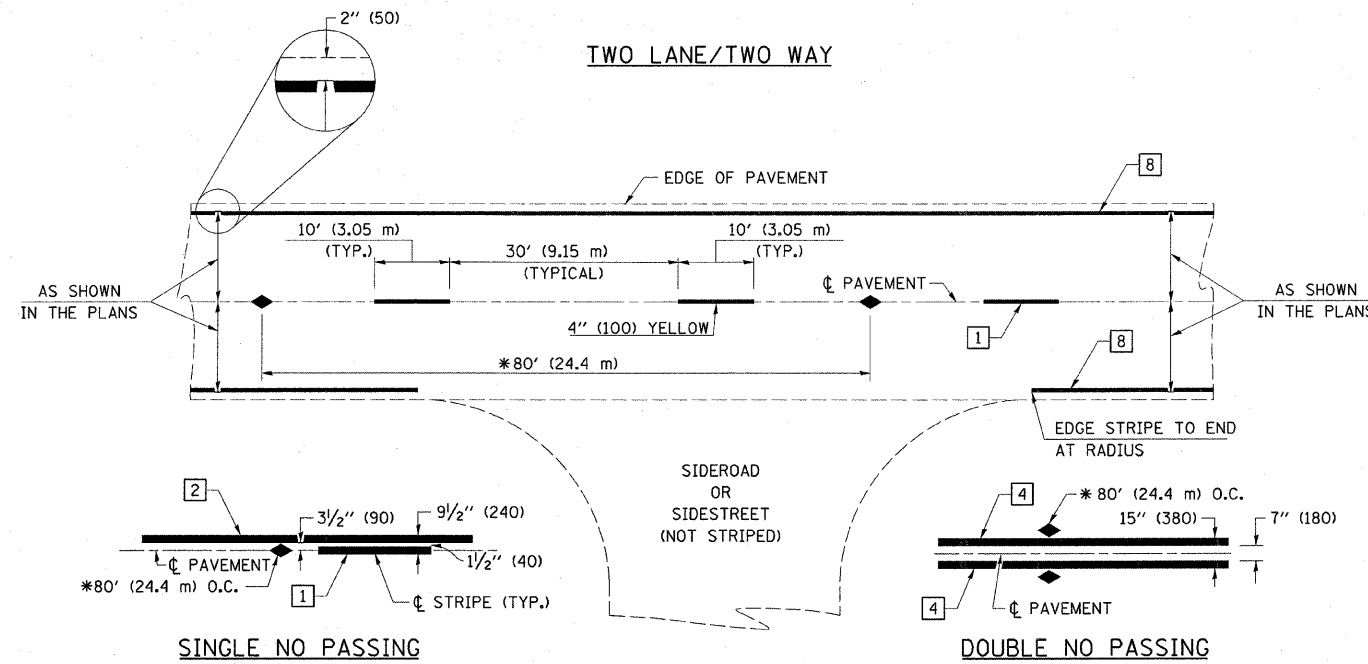

* REDUCE TO 40' (12.2 m) O.C. ON CURVES WITH POSTED OR ADVISORY SPEEDS OF 45 mph (70 km/h) OR LESS.

PAVEMENT MARKING LEGEND

- 1 4" (100) SKIP-DASH (YELLOW)
- 2 4" (100) SOLID (YELLOW)
- 3 12" (300) DIAGONAL (YELLOW)
- 4 4" (100) DOUBLE YELLOW (NARROW)
- 5 RESERVED
- 6 RESERVED
- 7 6" (150) SKIP-DASH (WHITE)
- 8 4" (100) SOLID (WHITE)
- 9 12" (300) DIAGONAL (WHITE)
- 10 6" (150) SOLID (WHITE)
- 11 24" (600) STOP BAR (WHITE)
- 12 8" (200) SOLID (WHITE)
- 13 6" (100) LANE LINE EXTENSIONS
- 14 4" (100) PARKING WHITE

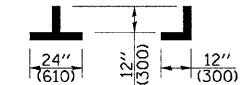
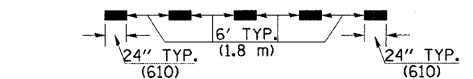
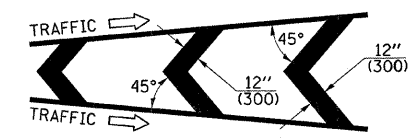
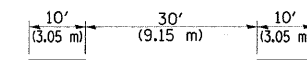
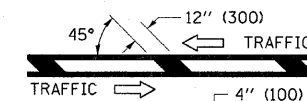
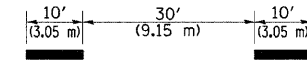

TYPICAL PAVEMENT MARKERS LEGEND

- ◆ TWO-WAY AMBER MARKER
- ▶ ONE-WAY AMBER MARKER
- ▷ ONE-WAY CRYSTAL MARKER

RAISED REFLECTIVE PAVEMENT MARKERS

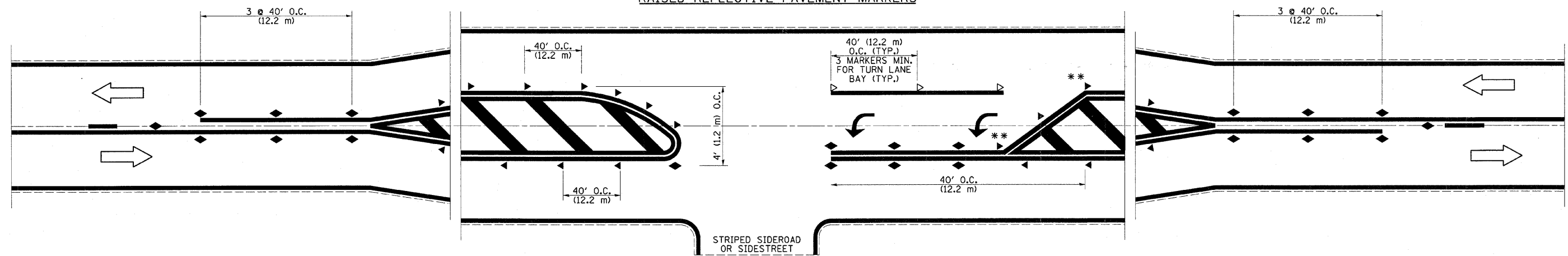

** REDUCE SPACING IF NECESSARY TO ASSURE MARKERS AT CORNER POINTS.

NOT TO SCALE
Note: All dimensions are in INCHES (millimeters) unless otherwise shown.

DISTRICT 7 DETAIL NO. 7800001

FILE NAME =	USER NAME = swartzw	DESIGNED -	REVISED -
ca:\pw\work\pav\dot\swartzw\d0242172\d77	507-shd-details.dgn	DRAWN -	REVISED -
	PLOT SCALE = 20,000 / IN.	CHECKED -	REVISED -
	PLOT DATE = 1/31/2011	DATE -	REVISED -

STATE OF ILLINOIS
DEPARTMENT OF TRANSPORTATION

PAVEMENT MARKING AND RAISED REFLECTIVE PAVEMENT MARKERS
(RURAL & URBAN APPLICATIONS)

SCALE: NA SHEET NO. 1 OF 6 SHEETS STA. TO STA.

F.A.S. RTE.	SECTION	COUNTY	TOTAL SHEETS	SHEET NO.
677	(15-2.15-1,15,11)RS-1	COLES	63	58
CONTRACT NO. 74507			ILLINOIS FED. AID PROJECT	

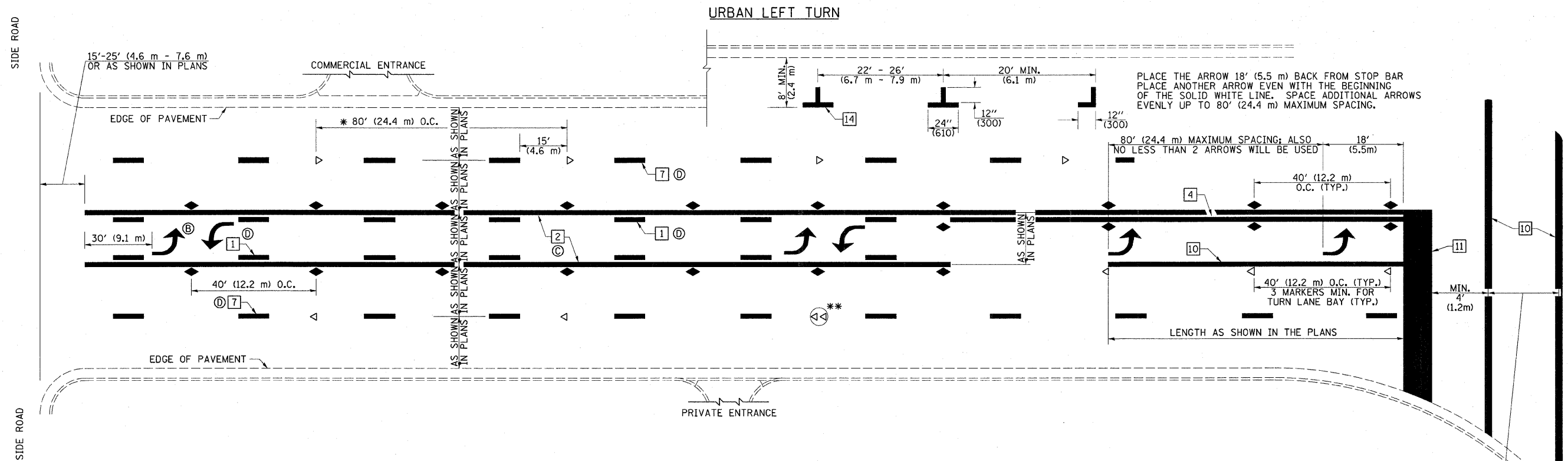

* REDUCE TO 40 FEET (12.2 METERS) SPACING ON CURVES WHERE ADVISORY SPEEDS ARE 10 MPH (15 km/h) LOWER THAN POSTED SPEEDS.

** DOUBLE LANE LINE MARKERS SHALL BE SPECIFIED AND SPACED AS SHOWN IN HIGHWAY STANDARD 781001 FOR MULTI-LANE DIVIDED AND UNDIVIDED HIGHWAYS.

PAVEMENT MARKING LEGEND

- 1 4" (100) SKIP-DASH (YELLOW)
 - 2 4" (100) SOLID (YELLOW)
 - 3 12" (300) DIAGONAL (YELLOW)
 - 4 4" (100) DOUBLE YELLOW (NARROW)
 - 5 RESERVED
 - 6 RESERVED
 - 7 6" (150) SKIP-DASH (WHITE)
 - 8 4" (100) SOLID (WHITE)
 - 9 12" (300) DIAGONAL (WHITE)
 - 10 6" (150) SOLID (WHITE)
 - 11 24" (600) STOP BAR (WHITE)
 - 12 8" (200) SOLID (WHITE)
 - 13 6" (100) LANE LINE EXTENSIONS (WHITE)
 - 14 4" (100) PARKING WHITE
-

GENERAL NOTES

- ⓑ TURN ARROW PAIRS SHALL BE PLACED AT 250' (75 m) INTERVALS AND SHALL BE EVENLY SPACED BETWEEN BOTH ENDS OF THE BIDIRECTIONAL LEFT TURN LANE. USE A MINIMUM OF TWO PAIRS PER BLOCK.
- ⓒ THE SOLID YELLOW PAVEMENT MARKINGS [2] SHOULD GENERALLY START OR END NEAR THE RADIUS POINT OF EACH STREET RETURN EXCEPT WHERE ONE OR BOTH ENDS WOULD INCLUDE STOP BARS.
- ⓓ THE SKIP-DASH PAVEMENT MARKINGS [1] OR [7] SHOULD BE CENTERED BETWEEN BOTH ENDS OF EACH CITY BLOCK AND SHALL BE PLACED SO THEY LINE UP ACROSS FROM EACH OTHER.
- ⓔ USE LARGE ARROW SIZE FOR BOTH RURAL AND URBAN LOCATIONS. (SEE LAST PAGE OF SECTION 780X FOR SYMBOLS TABLE)

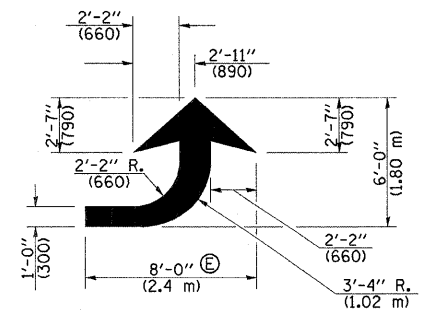
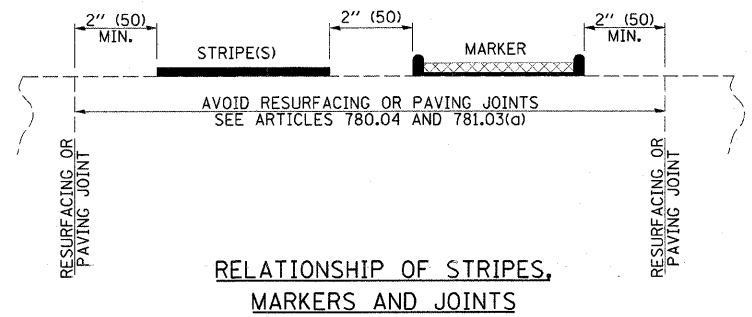

LEFT ARROW
REVERSE FOR RIGHT ARROW
AREA = 15.6 SQ. FT. (1.47 m²)
(WHITE)

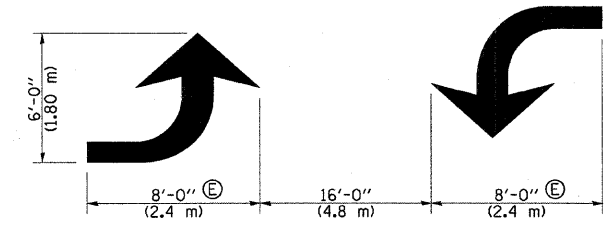

TYPICAL DOUBLE TURN ARROWS (WHITE)

NOT TO SCALE
Note: All dimensions are in INCHES (millimeters) unless otherwise shown.

FILE NAME =	USER NAME = swartzrw	DESIGNED -	REVISED -	STATE OF ILLINOIS DEPARTMENT OF TRANSPORTATION	PAVEMENT MARKING AND RAISED REFLECTIVE PAVEMENT MARKERS (RURAL & URBAN APPLICATIONS)	F.A.S. RTE.	SECTION	COUNTY	TOTAL SHEETS	SHEET NO.	
ct:\pw_work\p\dot\swartzrw\d8242172\d77	507-shd-details.dgn	DRAWN -	REVISED -			677	(15-2,15-1,15,11)RS-1	COLES	63	59	
	PLOT SCALE = 20,000' / IN.	CHECKED -	REVISED -			CONTRACT NO. 74507					
	PLOT DATE = 1/31/2011	DATE -	REVISED -			ILLINOIS FED. AID PROJECT					

PAVEMENT MARKINGS AT RAILROAD-HIGHWAY GRADE CROSSING

PAVEMENT MARKING LEGEND

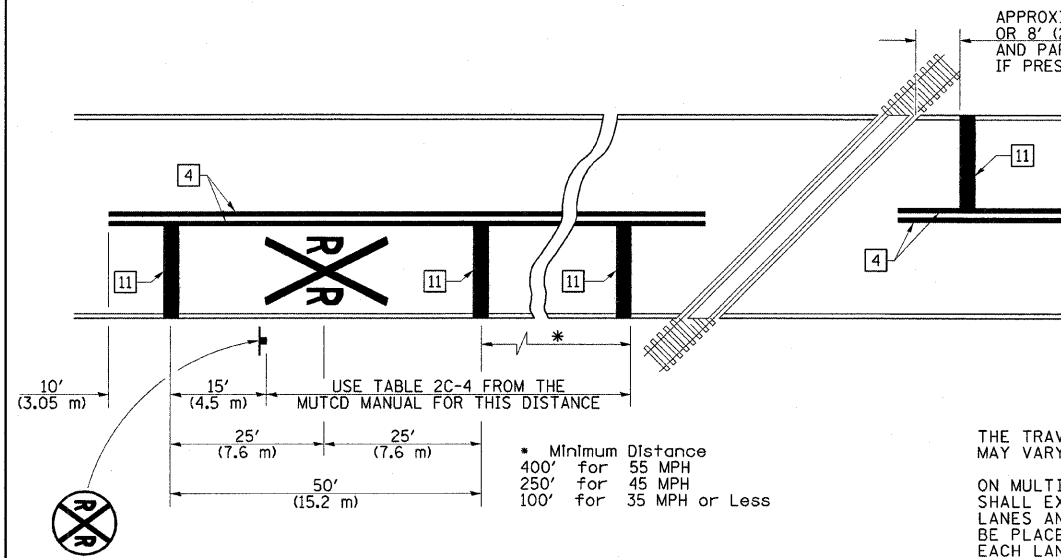

NOTES

THE TRAVERSE SPREAD OF THE "X" MAY VARY ACCORDING TO LANE WIDTH.

ON MULTI-LANE ROADS, THE STOP LINES SHALL EXTEND ACROSS ALL APPROACH LANES AND SEPARATE RXR SYMBOLS SHALL BE PLACED ADJACENT TO EACH OTHER IN EACH LANE.

WHEN THE PAVEMENT MARKING SYMBOL IS USED, A PORTION OF THE SYMBOL SHOULD BE LOCATED DIRECTLY ADJACENT TO THE ADVANCE WARNING SIGN (W10-1) AS PLACED BY TABLE II-1, CONDITION B OF THE MUTCD.

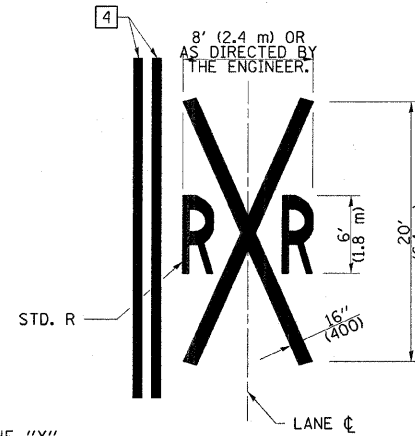

- 1 4" (100) SKIP-DASH (YELLOW)
- 2 4" (100) SOLID (YELLOW)
- 3 12" (300) DIAGONAL (YELLOW)
- 4 4" (100) DOUBLE YELLOW (NARROW)
- 5 RESERVED
- 6 RESERVED
- 7 6" (150) SKIP-DASH (WHITE)
- 8 4" (100) SOLID (WHITE)
- 9 12" (300) DIAGONAL (WHITE)
- 10 6" (150) SOLID (WHITE)
- 11 24" (600) STOP BAR (WHITE)
- 12 8" (200) SOLID (WHITE)
- 13 6" (100) LANE LINE EXTENSIONS
- 14 4" (100) PARKING WHITE

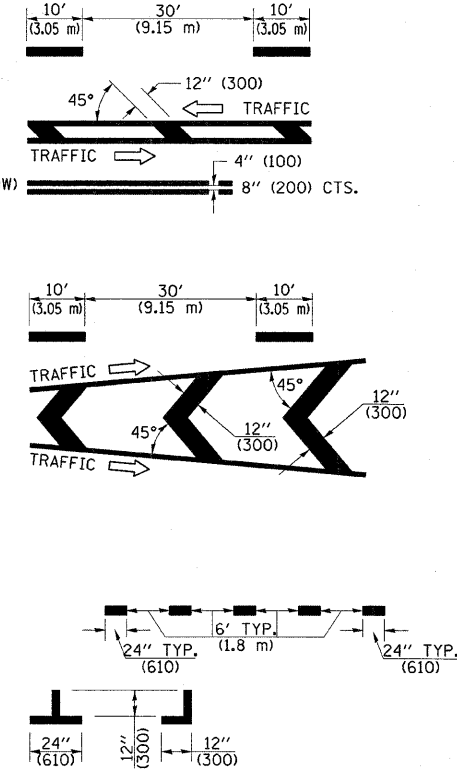

RAILROAD CROSSING WITH INTERCONNECT ONLY

RAILROAD CROSSING WITH INTERCONNECT AND PRE-SIGNALS

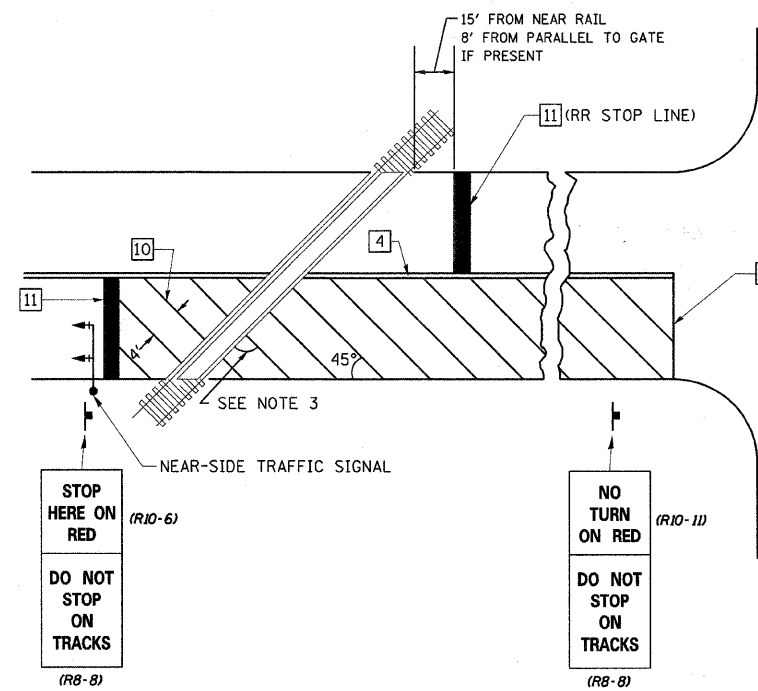
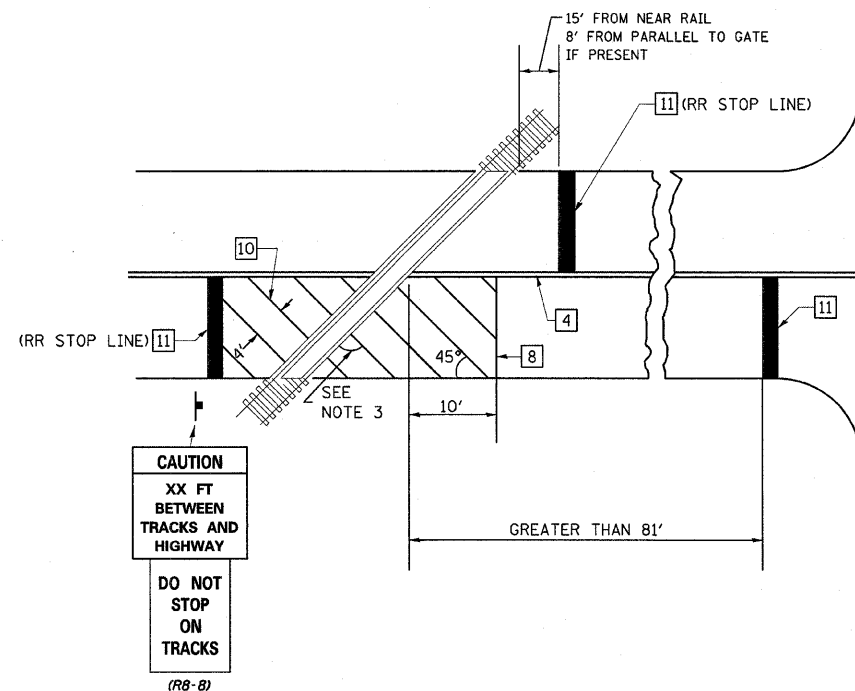

GENERAL NOTES

1. SUPPLEMENTAL PAVEMENT MARKINGS TO BE INSTALLED ONLY ON APPROACHES TO INTERSECTIONS CONTROLLED BY TRAFFIC SIGNALS WHICH ARE INTERCONNECTED WITH THE RAILROAD WARNING SIGNALS.
2. EXTEND PAVEMENT MARKINGS TO THE INTERSECTION ONLY WHERE NEAR-SIDE TRAFFIC SIGNALS ARE USED.
3. WHERE THE ANGLE BETWEEN THE DIAGONAL PAVEMENT MARKINGS AND THE TRACK WOULD BE LESS THAN 20°, THE PAVEMENT MARKINGS SHOULD BE PLACED IN THE OPPOSITE DIRECTION FROM THAT SHOWN.

SUPPLEMENTAL PAVEMENT MARKING TREATMENT FOR RAILROAD-HIGHWAY GRADE CROSSING

NOT TO SCALE

Note: All dimensions are in INCHES (millimeters) unless otherwise shown.

FILE NAME =	USER NAME = swartzrw	DESIGNED -	REVISED -	STATE OF ILLINOIS DEPARTMENT OF TRANSPORTATION	PAVEMENT MARKING AND RAISED REFLECTIVE PAVEMENT MARKERS (RURAL & URBAN APPLICATIONS)	F.A.S. RTE.	SECTION	COUNTY	TOTAL SHEETS	SHEET NO.	
ca:\pv_work\pwsdot\swartzrw\0242172\d77-507-shr-details.dgn		DRAWN -	REVISED -			677	(15-2,15-1,15,11)RS-1	COLES	63	61	
		CHECKED -	REVISED -			CONTRACT NO. 74507					
		DATE -	REVISED -			ILLINOIS FED. AID PROJECT					

TO BE INSTALLED IN RIGID OR COMPOSITE PAVEMENT FOR PRESERVING LAND SURVEY MONUMENTS (SECTION OR SUBSECTION CORNERS)

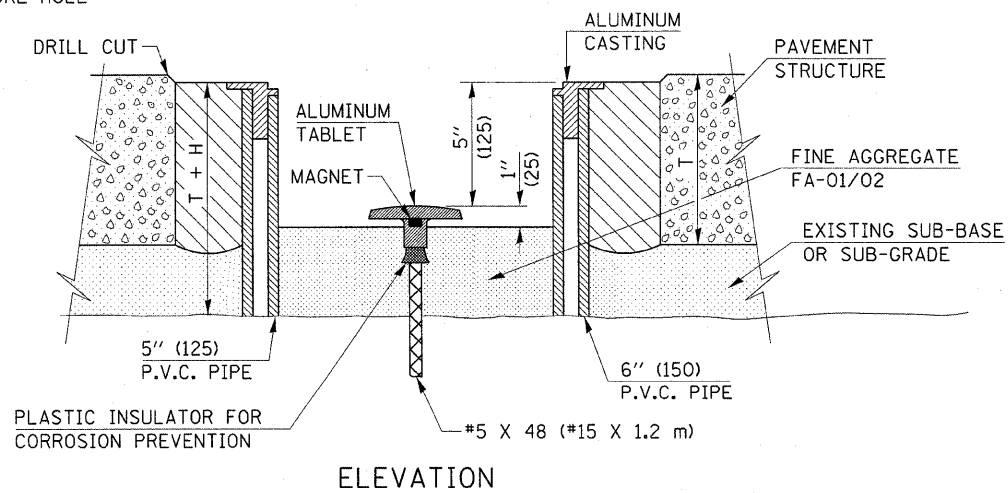
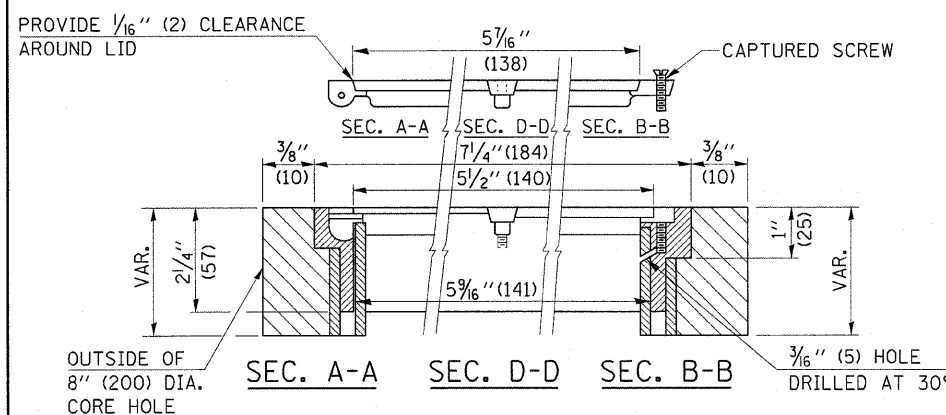
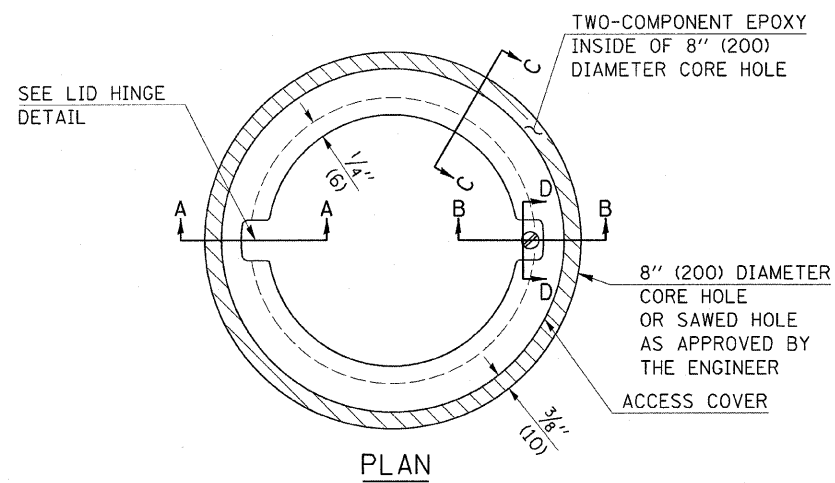

LEGEND

- ALUMINUM CASTING
- 5" (125) OR 6" (150) P.V.C. PIPE
- TWO-COMPONENT EPOXY

T = THICKNESS OF PAVEMENT STRUCTURE
H = THE THICKNESS OF THE SUB-BASE GRANULAR + 1" (25)

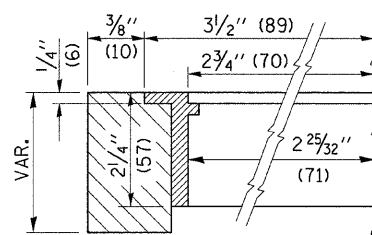

SECTION C-C

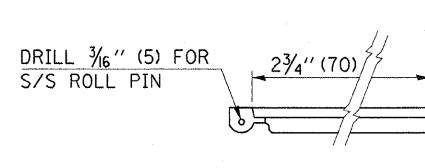

LID HINGE DETAIL

SPECIFICATIONS FOR ACCESS COVER FOR USE WITH SURVEY MARKER VAULT(S) AND SURVEY MARKER COVER ASSEMBLY(S): THE ACCESS COVER WILL BE CAST FROM A SPECIAL ALUMINUM ALLOY THAT IS COMPARABLE TO BRONZE IN HARDNESS. THE ACCESS COVER SHALL BE SPECIALLY ENGINEERED AND DESIGNED TO PROVIDE A SNUG FIT, INCORPORATING EQUIDISTANT LOCKING RIDGES, INSIDE A STANDARD 6" (150 mm) DIAMETER, OR OUTSIDE A STANDARD 5" (125 mm) DIAMETER, SCHEDULE 40 PVC PIPE. THE ACCESS COVER SHALL HAVE SPECIAL UNIFORM 1" (25 mm) THICK TOP SURFACE TO PERMIT INFORMATION TO BE EASILY MACHINE-STAMPED INTO IT. THE ACCESS COVER SHALL INCLUDE A STAINLESS CAPTURED SCREW AND AN OPPOSING RECESSED HINGE ASSEMBLY AS ITS LOCKING MECHANISM. THE ACCESS COVER SHALL INCORPORATE A SPECIAL ACCESS HOLE FOR CLEANING AND DRAINAGE, DRILLED AT 30° INSIDE THE RING OF THE ACCESS COVER, TO THE DRILLED AND TAPPED HOLE PROVIDED FOR THE STAINLESS CAPTURED SCREW. COMPOSITION: ALUMINUM 92-93%; MAGNESIUM 6.5-7.5%. STRENGTH: YIELD - 19,000-21,000 PSI (131-145 MPa); TENSILE - 38,000-44,000 PSI (262-303 MPa); ELONGATION - 10-15% IN 2" (50 mm). SPECIFICATIONS: ALLOY 535.0; QQ-A-601Es. NO EXCEPTIONS.

RE-BAR-SURVEY MARKER, TYPE I, (SPECIAL) TO BE FURNISHED BY THE CONTRACTOR AND SET BY AN ILLINOIS PROFESSIONAL LAND SURVEYOR (SEE SPECIAL DETAIL SHEET FOR ALUMINUM TABLET AND RE-BAR SPECIFICATIONS).

BILL OF MATERIAL

ALUMINUM CASTING OF THE DIMENSIONS AND SPECIFICATIONS SHOWN OR OTHER SUBJECT TO ENGINEER'S APPROVAL OF SHOP DRAWINGS, 5" OR 6" (125 mm OR 150 mm) DIAMETER P.V.C. PIPE, SCHEDULE 40, ALUMINUM TABLET, STAMPED IN ACCORDANCE WITH STANDARD 667101. 5/8" X 48" (#15 X 1.2 m) RE-BAR, EPOXY AND FA-01/02 AGGREGATE.

GENERAL NOTES

1. ALUMINUM CASTING SHALL BE EITHER PLACED OVER A 5" (125 mm) P.V.C. PIPE OR INSIDE OF A 6" (150 mm) P.V.C. PIPE.
2. BACKFILL WITH FINE AGGREGATE - FA-01/02.
3. WORK SHALL NOT START ON THIS ITEM UNTIL THE FINAL LIFT OF SURFACE HAS BEEN COMPLETED.
4. THIS WORK WILL BE PAID FOR AT THE CONTRACT UNIT PRICE EACH FOR SURVEY MARKER VAULT WHICH PRICE SHALL INCLUDE ALL LABOR AND MATERIAL AS SPECIFIED INCLUDING CORING, EPOXY AND FA-01/02 AGGREGATE AND NO ADDITIONAL COMPENSATION WILL BE ALLOWED.
5. THE CASTING SHALL BE ANCHORED IN THE 8" (200 mm) DIAMETER CORE HOLE WITH TWO-COMPONENT EPOXY CONFORMING TO APPLICABLE PORTIONS OF ARTICLE 1025.01 OF THE STANDARD SPECIFICATIONS.
6. ALL SURVEY MARKER (VAULTS) SHALL BE PLACED 1/4" (6 mm) ± BELOW THE FINAL SURFACE.
7. THE 8" (200 mm) DIAMETER CORE HOLE SHALL BE SUBJECT TO THE APPROVAL OF THE ENGINEER.

Note: All dimensions are in INCHES (millimeters) unless otherwise shown.

DISTRICT 7 DETAIL NO. X0301232

FILE NAME = c:\pwwork\pww\dot\swartzw\0242172\d77	USER NAME = swartzw	DESIGNED -	REVISED - 11/06	STATE OF ILLINOIS DEPARTMENT OF TRANSPORTATION	SURVEY MARKER VAULT	F.A.S. RTE.	SECTION	COUNTY	TOTAL SHEETS	SHEET NO.	
	587-shd-details.dgn	DRAWN -	REVISED -			677	(15-2,15-1,15,11)RS-1	COLES	63	62	
	PLOT SCALE = 20,0000' / IN.	CHECKED -	REVISED -			CONTRACT NO. 74507					
	PLOT DATE = 1/31/2011	DATE -	REVISED -			SCALE: NA SHEET NO. 5 OF 6 SHEETS STA. TO STA. FED. ROAD DIST. NO. ILLINOIS FED. AID PROJECT					

TO BE INSTALLED IN ALL PAVEMENT TYPES FOR PRESERVING PERMANENT SURVEY MARKERS (PI'S, PT'S, PC'S, POC'S, & POT'S) AND LAND SURVEY MONUMENTS (SECTION OR SUBSECTION CORNERS)

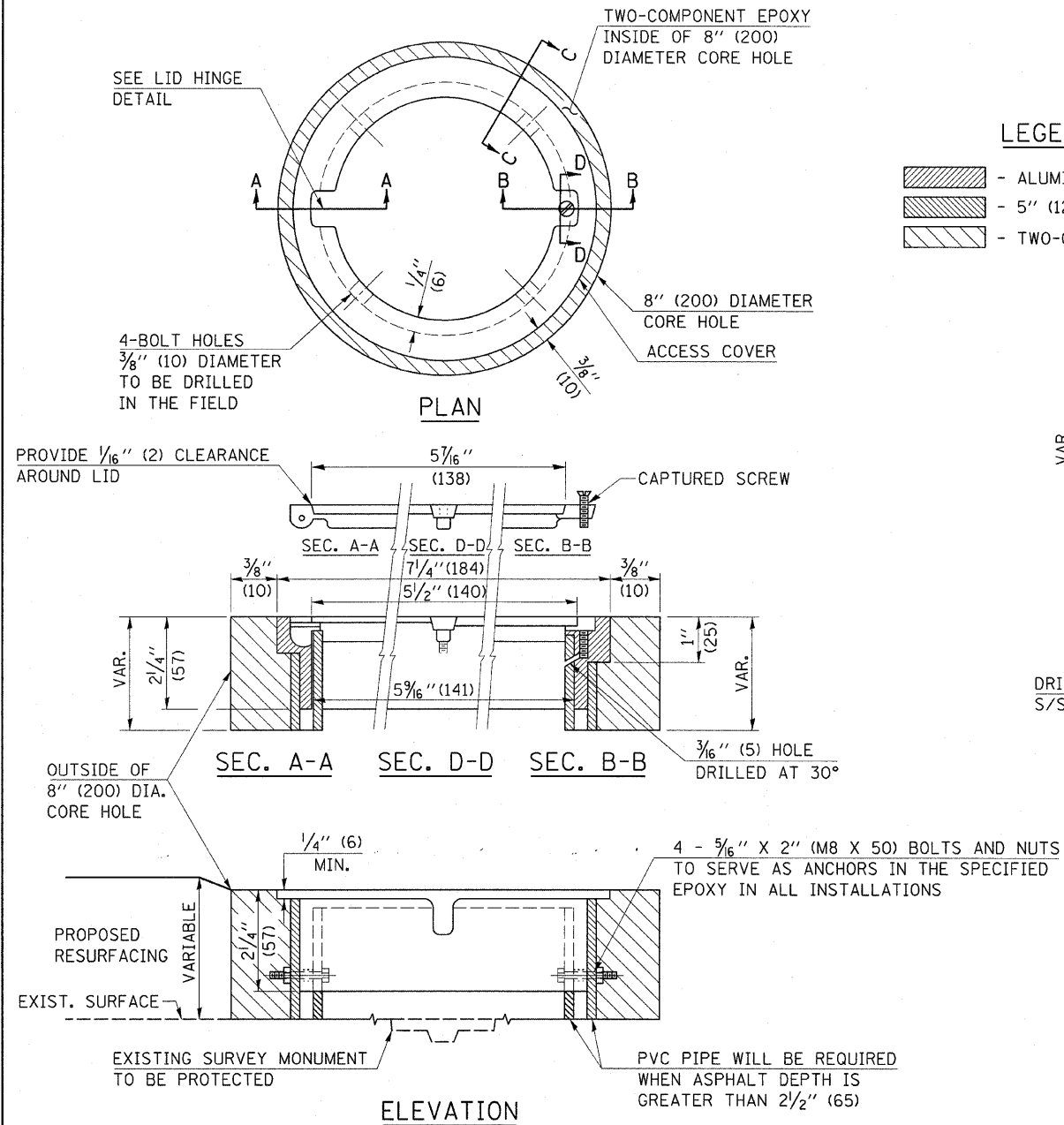

LEGEND

- ALUMINUM CASTING
- 5" (125) OR 6" (150) P.V.C. PIPE
- TWO-COMPONENT EPOXY

SPECIFICATIONS FOR ACCESS COVER FOR USE WITH SURVEY MARKER VAULT(S) AND SURVEY MARKER COVER ASSEMBLY(S): THE ACCESS COVER WILL BE CAST FROM A SPECIAL ALUMINUM ALLOY THAT IS COMPARABLE TO BRONZE IN HARDNESS. THE ACCESS COVER SHALL BE SPECIALLY ENGINEERED AND DESIGNED TO PROVIDE A SNUG FIT, INCORPORATING EQUIDISTANT LOCKING RIDGES, INSIDE A STANDARD 6" (150 mm) DIAMETER, OR OUTSIDE A STANDARD 5" (125 mm) DIAMETER, SCHEDULE 40 PVC PIPE. THE ACCESS COVER SHALL HAVE SPECIAL UNIFORM 1" (25 mm) THICK TOP SURFACE TO PERMIT INFORMATION TO BE EASILY MACHINE-STAMPED INTO IT. THE ACCESS COVER SHALL INCLUDE A STAINLESS CAPTURED SCREW AND AN OPPOSING RECESSED HINGE ASSEMBLY AS ITS LOCKING MECHANISM. THE ACCESS COVER SHALL INCORPORATE A SPECIAL ACCESS HOLE FOR CLEANING AND DRAINAGE, DRILLED AT 30° INSIDE THE RING OF THE ACCESS COVER, TO THE DRILLED AND TAPPED HOLE PROVIDED FOR THE STAINLESS CAPTURED SCREW. COMPOSITION: ALUMINUM 92-93%; MAGNESIUM 6.5-7.5%. STRENGTH: YIELD - 19,000-21,000 PSI (131-145 MPa); TENSILE - 38,000-44,000 PSI (262-303 MPa); ELONGATION - 10-15% IN 2" (50 mm). SPECIFICATIONS: ALLOY 535.0; QQ-A-601Es. NO EXCEPTIONS.

BILL OF MATERIAL	
ALUMINUM CASTING OF THE DIMENSIONS AND SPECIFICATIONS SHOWN OR OTHER SUBJECT TO ENGINEER'S APPROVAL OF SHOP DRAWINGS,	
4 EACH - 5/16" X 2" (M8 X 50) BOLTS WITH NUTS, EPOXY,	
5" OR 6" (125 mm OR 150 mm) DIAMETER P.V.C. PIPE, SCHEDULE 40 (WHEN REQUIRED).	

GENERAL NOTES

1. WORK SHALL NOT START ON THIS ITEM UNTIL THE FINAL LIFT OF SURFACE HAS BEEN COMPLETED.
2. THE SURVEY MONUMENT COVER ASSEMBLY SHALL BE CENTERED ABOVE THE SURVEY MONUMENT TO BE PROTECTED.
3. MODIFICATION OF THE ALUMINUM CASTING SHALL BE DONE BY GRINDING OR SAWING WHEN HEIGHT REDUCTION IS REQUIRED.
4. ALL SURVEY MONUMENT COVER ASSEMBLIES SHALL BE PLACED 1/4" (6 mm) ± BELOW THE FINAL SURFACE.
5. ALUMINUM CASTING SHALL BE PLACED OVER A 5" (125 mm) P.V.C. PIPE OR INSIDE OF A 6" (150 mm) P.V.C. PIPE WHEN AN INCREASE IN HEIGHT IS REQUIRED.
6. THE CASTING SHALL BE ANCHORED IN THE 8" (200 mm) DIAMETER CORE HOLE WITH TWO-COMPONENT EPOXY CONFORMING TO APPLICABLE PORTIONS OF ARTICLE 1025.01 OF THE STANDARD SPECIFICATIONS.
7. THIS WORK WILL BE PAID FOR AT THE CONTRACT UNIT PRICE EACH FOR SURVEY MONUMENT COVER ASSEMBLY WHICH PRICE SHALL INCLUDE ALL LABOR AND MATERIAL AS SPECIFIED INCLUDING CORING THE NEW PAVEMENT SURFACE AND EPOXY. NO ADDITIONAL COMPENSATION WILL BE ALLOWED.
8. THE 8" (200 mm) DIAMETER CORE HOLE SHALL BE SUBJECT TO THE APPROVAL OF THE ENGINEER.

Note: All dimensions are in INCHES (millimeters) unless otherwise shown.

FILE NAME =	USER NAME = swartzw	DESIGNED -	REVISED - 11/06
cd:\pwork\pwork\swartzw\d0242172\d774507-ahd\details.dgn		DRAWN -	REVISED -
PLOT SCALE = 20.0000' / IN.		CHECKED -	REVISED -
PLOT DATE = 1/31/2011		DATE -	REVISED -

**STATE OF ILLINOIS
DEPARTMENT OF TRANSPORTATION**

SURVEY MONUMENT COVER ASSEMBLY

SCALE: NA SHEET NO. 6 OF 6 SHEETS STA. TO STA.

DISTRICT 7 DETAIL NO. Z0070100				
F.A.S. RTE.	SECTION	COUNTY	TOTAL SHEETS	SHEET NO.
677	(15-2,15-1,15,11)RS-1	COLES	63	63
FED. ROAD DIST. NO. ILLINOIS FED. AID PROJECT			CONTRACT NO. 74507	