

PROPOSED  
TYPICAL SECTION  
(NOLEMAN STREET)  
STA. 6+42.00 TO STA. 19+15.80  
STA. 39+80.38 TO STA. 54+71.00

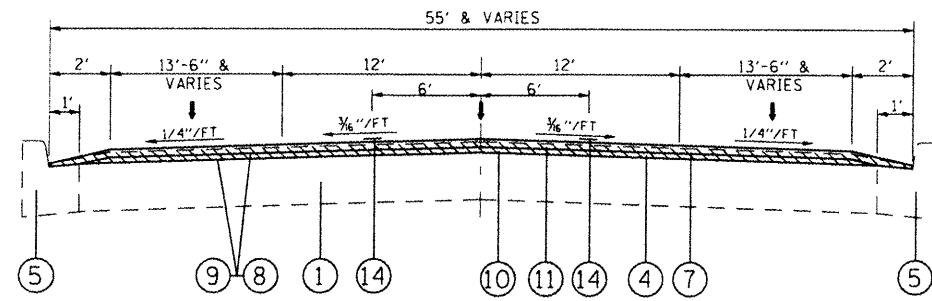

PROPOSED  
TYPICAL SECTION  
(NOLEMAN STREET)  
STA. 29+31.00 TO STA. 39+80.38

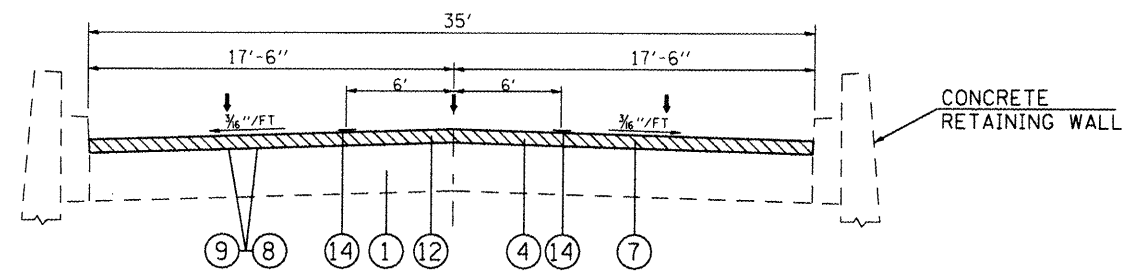

PROPOSED  
TYPICAL SECTION  
(NOLEMAN STREET)  
STA. 19+15.80 TO STA. 29+31.00

**LEGEND**

- ① EXISTING PAVEMENT
- ② EXISTING PCC WIDENING, 8"
- ③ EXISTING HMA RESURFACING, 4"
- ④ EXISTING HMA RESURFACING, 2"
- ⑤ EXISTING CONC. CURB & GUTTER
- ⑥ PROPOSED HMA SURFACE REMOVAL, 2 1/4"
- ⑦ PROPOSED HMA SURFACE REMOVAL, 2"
- ⑧ PROPOSED BITUMINOUS MATERIALS (PRIME COAT)
- ⑨ PROPOSED AGGREGATE (PRIME COAT)
- ⑩ PROPOSED LEVELING BINDER IL 4.75, 3/4 "
- ⑪ PROPOSED SURFACE COURSE, 1 1/2"
- ⑫ PROPOSED SURFACE COURSE, 2"
- ⑬ PROPOSED STRIP REFLECTIVE CRACK CONTROL
- ⑭ PROPOSED PAVEMENT MARKING

NOTE:  
THE INTENT OF THE MILLING IS TO REMOVE  
HMA SURFACE MATERIAL ONLY. THE UNDERLYING  
CONCRETE PAVEMENT SHALL NOT BE DISTURBED.

FILE NAME : #FILE#	USER NAME : #USER#	DESIGNED -	REVISED -	<b>STATE OF ILLINOIS DEPARTMENT OF TRANSPORTATION</b>	<b>TYPICAL SECTIONS (RESURFACING SECTION)</b>	F.A.P. RTE. 805	SECTION (TZ-2, BZ-2IRS-1)	COUNTY *	TOTAL SHEETS 21	SHEET NO. 8	
PLOT SCALE : #SCALE#	CHECKED -	REVISED -	SCALE: _____			SHEET NO. _____ OF _____ SHEETS	STA. _____ TO STA. _____	CONTRACT NO. 76E51			
PLOT DATE : #DATE#	DATE -	REVISED -	FED. ROAD DIST. NO. _____ [ILLINOIS] FED. AID PROJECT *CLINTON/MARION								