

STATE OF ILLINOIS
DEPARTMENT OF TRANSPORTATION

F.A. RTE.	SECTION	COUNTY	TOTAL SHEETS	SHEET NO.
"	(9,10,11)RS-4 (9-1,9)RS-1	MCLEAN	45	1
*FAS 2466 & FAP 676		ILLINOIS	CONTRACT NO. 70E03	

FOR INDEX OF SHEETS, SEE SHEET NO. 2
FOR SUMMARY OF QUANTITIES, SEE SHEETS NO. 3-5

PROPOSED HIGHWAY PLANS

FAS ROUTE 2466 & FAP ROUTE 676 (US 150)
SECTION (9,10,11)RS-4,(9-1,9)RS-1
PROJECT NHPP-STP-4CT4(284)
PAVEMENT PRESERVATION
CAPE SEAL
MCLEAN COUNTY

P-95-010-21

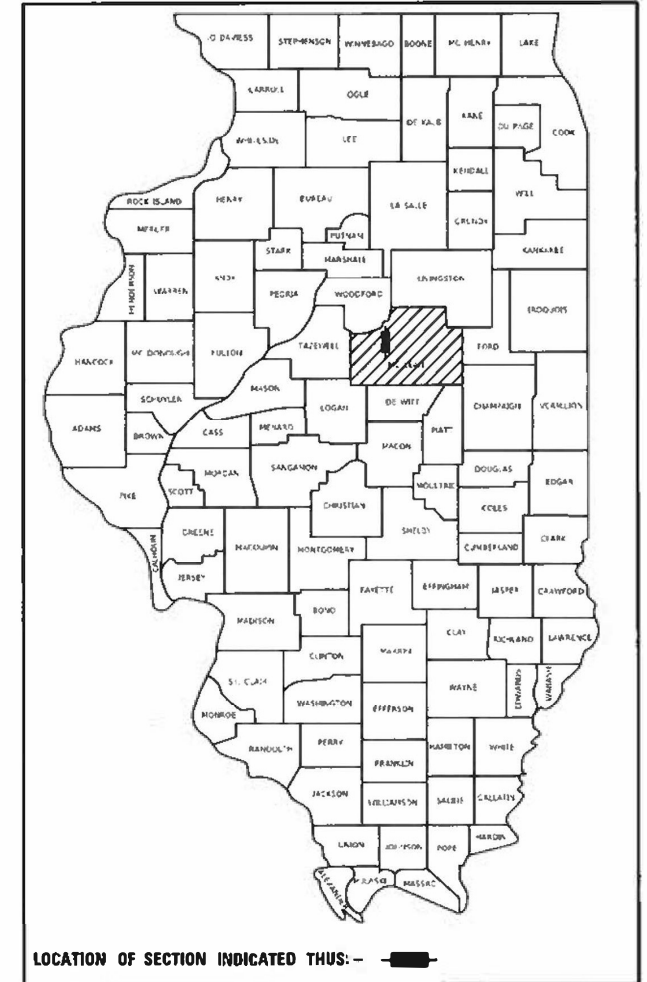

LOCATION OF SECTION INDICATED THIS: —

CURRENT TRAFFIC DATA						
FAS ROUTE 2466 & FAP ROUTE 676 (US 150)						
	LEG "A"	LEG "B"	LEG "C"	LEG "D"	LEG "E"	LEG "F"
2021 ADT	1,350	2,750	5,600	3,100	2,500	3,250
P.V.%	86.7	82.0	91.2	89.7	89.2	91.7
S.U.%	4.4	6.2	4.3	4.8	5.2	4.3
M.U.%	8.9	11.8	4.5	5.5	5.6	4.0

DESCRIPTION OF LEGS

- LEG "A": US 150 FROM WOODFORD COUNTY LINE TO WASHINGTON ST. IN CARLOCK
- LEG "B": US 150 FROM WASHINGTON ST. IN CARLOCK TO I-74
- LEG "C": US 150 FROM I-74 TO MABEL RD.
- LEG "D": US 150 FROM MABEL RD. TO RAAB RD.
- LEG "E": US 150 FROM RAAB RD. TO COLLEGE AVE.
- LEG "F": US 150 FROM COLLEGE AVE TO IL 9 (MARKET ST.)

DESIGN DESIGNATION
N/A

C-95-043-21
WOODFORD CO LINE TO ILL 9 W OF BLOOMINGTON

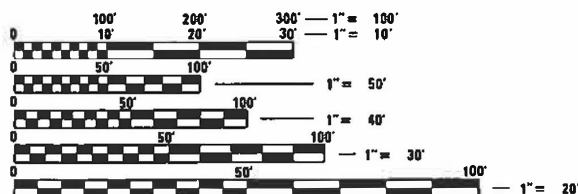

FULL SIZE PLANS HAVE BEEN PREPARED USING STANDARD ENGINEERING SCALES. REDUCED SIZED PLANS WILL NOT CONFORM TO STANDARD SCALES. IN MAKING MEASUREMENTS ON REDUCED PLANS, THE ABOVE SCALES MAY BE USED.

J.U.L.I.E.
JOINT UTILITY LOCATION INFORMATION FOR EXCAVATORS
1-800-892-0123
OR 811 WHITE OAK & DRY GROVE TOWNSHIP

PROJECT ENGINEER: JASON W. STULTS, P.E.
DESIGN SQUAD LEADER: DAVID F. JAYME, P.E.
DESIGNER: MATTHEW J. KEYS
PHONE NUMBER: (217)465-4181
CONTRACT NO. 70E03

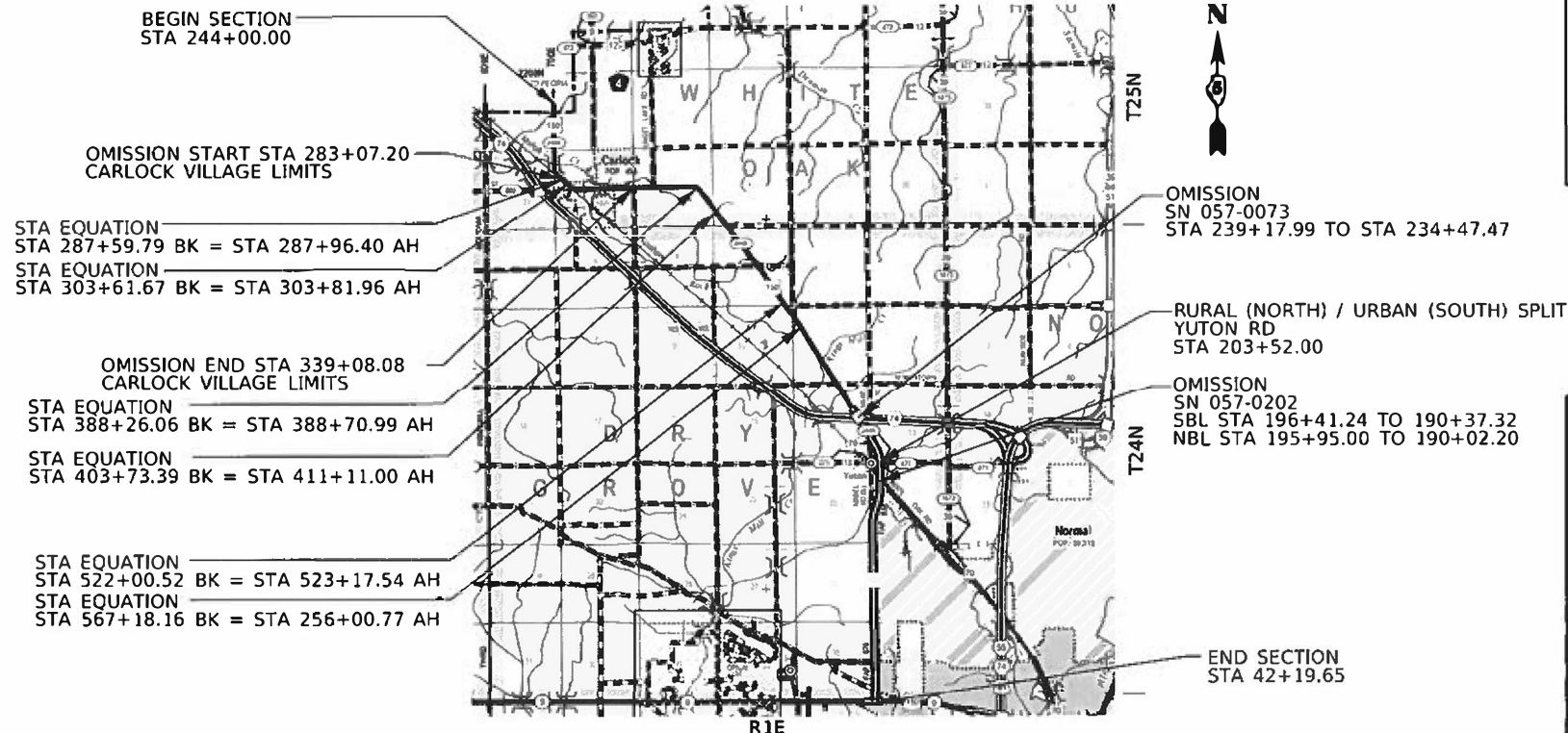

GROSS LENGTH = 52,742.82 FT = 9.989 MI
NET LENGTH = 46,129.91 FT = 8.737 MI



STATE OF ILLINOIS
DEPARTMENT OF TRANSPORTATION

SUBMITTED 1/27 20 22
Kamil A. Barnett
REGIONAL ENGINEER

March 25 2022
[Signature]
ENGINEER OF DESIGN AND ENVIRONMENT

March 23 2022
Stephen M. Smith
DIRECTOR OF HIGHWAYS PROJECT IMPLEMENTATION

PRINTED BY THE AUTHORITY
OF THE STATE OF ILLINOIS

INDEX OF SHEETS

- 1 COVER SHEET
- 2 INDEX OF SHEETS, LIST OF HIGHWAY STANDARDS, GENERAL NOTES, AND COMMITMENTS
- 3 - 5 SUMMARY OF QUANTITIES
- 6 -15 EXISTING AND PROPOSED TYPICAL CROSS SECTIONS
- 16-22 SCHEDULES OF QUANTITIES
- 23-39 PLAN SHEETS
- 40 CAPE SEAL RUNDOWN DETAIL
- 41-45 PAVEMENT MARKING AND MARKERS (RURAL AND URBAN APPLICATIONS)

GENERAL NOTES

G.N.-100A
ELECTRONIC FILES AND/OR ELECTRONIC SURVEY INFORMATION INCLUDING CADD FILES WILL NOT BE AVAILABLE TO THE CONTRACTOR.

G.N.-703A
SHORT TERM PAVEMENT MARKING SHALL BE APPLIED TO THE PAVEMENT AFTER ANY OF THE FOLLOWING: COLD MILLING AND/OR PLACING BITUMINOUS MATERIALS (TACK COAT), LEVELING BINDER (MACHINE METHOD), BINDER AND SURFACE COURSES. SHORT TERM PAVEMENT MARKING PLACED ON THE SURFACE SHALL COINCIDE WITH THE FINAL PAVEMENT STRIPING. SHORT TERM PAVEMENT MARKING PLACED PRIOR TO THE SURFACE SHALL COINCIDE WITH THE EXISTING PAVEMENT MARKINGS. USE 4 FEET PER 40 FEET (OR 10% PER STATION).

G.N.-781
THE FINAL PAVEMENT MARKINGS SHALL BE IN PLACE PRIOR TO PLACING THE RAISED REFLECTIVE PAVEMENT MARKERS.

LIST OF HIGHWAY STANDARDS

- 000001-08 STANDARD SYMBOLS, ABBREVIATIONS, AND PATTERNS
- 001006 DECIMAL OF AN INCH AND OF A FOOT
- 701006-05 OFF-RD OPERATIONS, 2L, 2W, 15' (4.5 M) TO 24" (600 MM) FROM PAVEMENT EDGE
- 701201-05 LANE CLOSURE, 2L, 2W, DAY ONLY, FOR SPEEDS ≥ 45 MPH
- 701301-04 LANE CLOSURE, 2L, 2W, SHORT TIME OPERATIONS
- 701306-04 LANE CLOSURE 2L, 2W, SLOW MOVING OPERATIONS-DAY ONLY, FOR SPEEDS ≥ 45 MPH
- 701311-03 LANE CLOSURE 2L, 2W, MOVING OPERATIONS- DAY ONLY
- 701426-09 LANE CLOSURE, MULTILANE,INTERMITTENT OR MOVING OPER., FOR SPEEDS ≥ 45 MPH
- 701601-09 URBAN LANE CLOSURE, 1W OR 2W WITH NONTRAVERSABLE MEDIAN
- 701901-08 TRAFFIC CONTROL DEVICES
- 780001-05 TYPICAL PAVEMENT MARKINGS
- 781001-04 TYPICAL APPLICATIONS RAISED REFLECTIVE PAVEMENT MARKERS

COMMITMENTS

NO COMMITMENTS

MODEL: S:\MODEL\NAMES
FILE NAME: I:\work\new\jenmby.com\PI\DOT\Documents\DOT_Offices\lbrf.ctb S:\projects\0570E03\CAD\Drawings\CAD\Sheet\0570E03-01-GeneralNotes.dgn

USER NAME = monjardlbrt	DESIGNED -	REVISED -
	DRAWN -	REVISED -
PLOT SCALE = 40,0936 ' / in.	CHECKED -	REVISED -
PLOT DATE = 1/27/2022	DATE -	REVISED -

**STATE OF ILLINOIS
DEPARTMENT OF TRANSPORTATION**

**INDEX OF SHEETS, LIST OF HIGHWAY STANDARDS,
GENERAL NOTES, AND COMMITMENTS**

SCALE: 1:20 SHEET 1 OF 1 SHEETS STA. TO STA.

F.A. RTE.	SECTION	COUNTY	TOTAL SHEETS	SHEET NO.
*	(9,10,11)RS-4,(9-1,9)RS-1	MCLEAN	45	2
*FAS 2466 & FAP 676			CONTRACT NO. 70E03	
ILLINOIS FED. AID PROJECT				

SUMMARY OF QUANTITIES

LOCATION OF WORK:	F.A.S. 2466 (US 150) RURAL 2L2W MAJOR COLLECTOR STA 244+00.00 TO STA 241+36.92 MCLEAN COUNTY	F.A.S. 2466 (US 150) RURAL 2L2W OTHER PRINCIPAL ARTERIAL STA 241+36.92 TO STA 235+00.00 MCLEAN COUNTY	F.A.P. 676 (US 150) RURAL 2L2W OTHER PRINCIPAL ARTERIAL STA 235+00.00 TO STA 203+52.00 MCLEAN COUNTY	F.A.P. 676 (US 150) URBAN MULTILANE OTHER PRINCIPAL ARTERIAL STA 203+52.00 TO STA 42+19.65 MCLEAN COUNTY
FUNDING BREAKOUT:	80% FED/20% STATE (STP)	80% FED/20% STATE (NHPP)	80% FED/20% STATE (NHPP)	80% FED/20% STATE (NHPP)
CONSTRUCTION TYPE CODE:	0005	0005	0005	0005

CODE NO.	ITEM	UNIT	TOTAL QUANTITY	QUANTITY	QUANTITY	QUANTITY	QUANTITY
40400001	FIBER-MODIFIED ASPHALT CRACK SEALING	FOOT	92,260.0	55,001.2		6,190.9	31,067.9
40400020	BUMP REMOVAL	EACH	150.0	73.0	2.0	10.0	65.0
40500061	CAPE SEAL	SQ YD	195,804.0	74,530.2	1,397.7	20,173.0	99,703.1
48102100	AGGREGATE WEDGE SHOULDER, TYPE B	TON	1,677.0	1,677.0			
67000500	ENGINEER'S FIELD OFFICE, TYPE B	CAL MO	4.0	1.8	0.2	0.2	1.8
67100100	MOBILIZATION	L SUM	1.0	0.4	0.1	0.1	0.4
70100450	TRAFFIC CONTROL AND PROTECTION, STANDARD 701201	L SUM	1.0	0.9	0.1		
70100460	TRAFFIC CONTROL AND PROTECTION, STANDARD 701306	L SUM	1.0	0.9	0.1		
70102630	TRAFFIC CONTROL AND PROTECTION, STANDARD 701601	L SUM	1.0				1.0
70300100	SHORT TERM PAVEMENT MARKING	FOOT	28,918.0	11,245.2	183.9	3,183.8	14,305.1
70300150	SHORT TERM PAVEMENT MARKING REMOVAL	SQ FT	2,176.0	939.0	17.4	182.5	1,037.1
70300211	TEMPORARY PAVEMENT MARKING LETTERS AND SYMBOLS - PAINT	SQ FT	1,311.0			296.4	1,014.6
70300221	TEMPORARY PAVEMENT MARKING - LINE 4" - PAINT	FOOT	171,939.0	72,911.3	492.6	18,543.7	79,991.4
70300241	TEMPORARY PAVEMENT MARKING - LINE 6" - PAINT	FOOT	705.0			125.0	580.0

* DENOTES SPECIALTY ITEM

MODEL: \\MODEL\NAME\$
FILE: \\NAME\$.prn | \\SERVER\Bentley.com\PROJECTS\DOT\OFFICE\DOT\Projects\157003\CD\Drawings\157003.sht,500.dgn

USER NAME = monjardnrt	DESIGNED -	REVISED -	
	DRAWN -	REVISED -	
PLOT SCALE = 40.0009 ' / in.	CHECKED -	REVISED -	
PLOT DATE = 3/10/2022	DATE -	REVISED -	

**STATE OF ILLINOIS
DEPARTMENT OF TRANSPORTATION**

SUMMARY OF QUANTITIES

SCALE: SHEET 1 OF 3 SHEETS STA. TO STA.

F.A. RTE.	SECTION	COUNTY	TOTAL SHEETS	SHEET NO.
*	(9,10,11)RS-4,(9-1,9)RS-1	MCLEAN	45	3
*FAS 2466 & FAP 676		CONTRACT NO. 70E03		
ILLINOIS FED. AID PROJECT				

SUMMARY OF QUANTITIES

LOCATION OF WORK: F.A.S. 2466 (US 150) RURAL 2L2W MAJOR COLLECTOR STA 244+00.00 TO STA 241+36.92 MCLEAN COUNTY FUNDING BREAKOUT: 80% FED/20% STATE (STP) 0005 CONSTRUCTION TYPE CODE: 0005	F.A.S. 2466 (US 150) RURAL 2L2W OTHER PRINCIPAL ARTERIAL STA 241+36.92 TO STA 235+00.00 MCLEAN COUNTY 80% FED/20% STATE (NHPP) 0005	F.A.P. 676 (US 150) RURAL 2L2W OTHER PRINCIPAL ARTERIAL STA 235+00.00 TO STA 203+52.00 MCLEAN COUNTY 80% FED/20% STATE (NHPP) 0005	F.A.P. 676 (US 150) URBAN MULTILANE OTHER PRINCIPAL ARTERIAL STA 203+52.00 TO STA 42+19.65 MCLEAN COUNTY 80% FED/20% STATE (NHPP) 0005
---	--	---	---

CODE NO.	ITEM	UNIT	TOTAL QUANTITY	QUANTITY	QUANTITY	QUANTITY
70300261	TEMPORARY PAVEMENT MARKING - LINE 12" - PAINT	FOOT	413.0			105.0 308.0
70300281	TEMPORARY PAVEMENT MARKING - LINE 24" - PAINT	FOOT	332.0			53.0 279.0
* 78000100	THERMOPLASTIC PAVEMENT MARKING - LETTERS AND SYMBOLS	SQ FT	1,311.0			296.4 1,014.6
* 78000200	THERMOPLASTIC PAVEMENT MARKING - LINE 4"	FOOT	103,946.0	4,918.3	492.6	18,543.7 79,991.4
* 78000400	THERMOPLASTIC PAVEMENT MARKING - LINE 6"	FOOT	705.0			125.0 580.0
* 78000600	THERMOPLASTIC PAVEMENT MARKING - LINE 12"	FOOT	413.0			105.0 308.0
* 78000650	THERMOPLASTIC PAVEMENT MARKING - LINE 24"	FOOT	332.0			118.0 214.0
* 78001110	PAINT PAVEMENT MARKING - LINE 4"	FOOT	67,993.0	67,993.0		
* 78011000	GROOVING FOR RECESSED PAVEMENT MARKING, LETTERS & SYMBOLS	SQ FT	1,311.0			296.4 1,014.6
* 78011025	GROOVING FOR RECESSED PAVEMENT MARKING 5"	FOOT	103,946.0	4,918.3	492.6	18,543.7 79,991.4
* 78011035	GROOVING FOR RECESSED PAVEMENT MARKING 7"	FOOT	705.0			125.0 580.0
* 78011065	GROOVING FOR RECESSED PAVEMENT MARKING 13"	FOOT	413.0			105.0 308.0
* 78011125	GROOVING FOR RECESSED PAVEMENT MARKING 25"	FOOT	332.0			118.0 214.0
* 78100100	RAISED REFLECTIVE PAVEMENT MARKER	EACH	925.0	393.0	10.0	92.0 430.0

* DENOTES SPECIALTY ITEM

MODEL: S:\MODEL\NAMES
 FILE NAME: p:\pub\dot-rw-bentley.com-p\INDOT\Documents\DOT Offres\DOT-11\11-11-2022\CAD\Drawings\DOT\11-11-2022\11-11-2022-11-11-2022.dgn

USER NAME = monjardnrrt	DESIGNED -	REVISED -
PLOT SCALE = 40.0739' / in.	DRAWN -	REVISED -
PLOT DATE = 3/10/2022	CHECKED -	REVISED -
	DATE -	REVISED -

**STATE OF ILLINOIS
 DEPARTMENT OF TRANSPORTATION**

SUMMARY OF QUANTITIES			
SCALE:	SHEET 2 OF 3 SHEETS	STA.	TO STA.

F.A. RTE.	SECTION	COUNTY	TOTAL SHEETS	SHEET NO.
*	(9,10,11)RS-4,(9-1,9)RS-1	MCLEAN	45	4
*FAS 2466 & FAP 676		CONTRACT NO. 70E03		
ILLINOIS FED. AID PROJECT				

NOTE: * OMISSION STA 283+07.20 TO STA 339+08.08

STATION EQUATIONS:

STA 287+59.81 (BK) = STA 287+96.40 (AH)

STA 388+26.06 (BK) = STA 388+70.99 (AH)

NOTE: SUPERELEVATION STATIONS

281+96.40 TO 287+59.81 (BK)

382+16.00 TO 388+26.11 (BK)

A EXISTING TYPICAL SECTION

STATION	TO	STATION
244+00.00		302+15.00*
*328+63.00		401+82.60 (B)

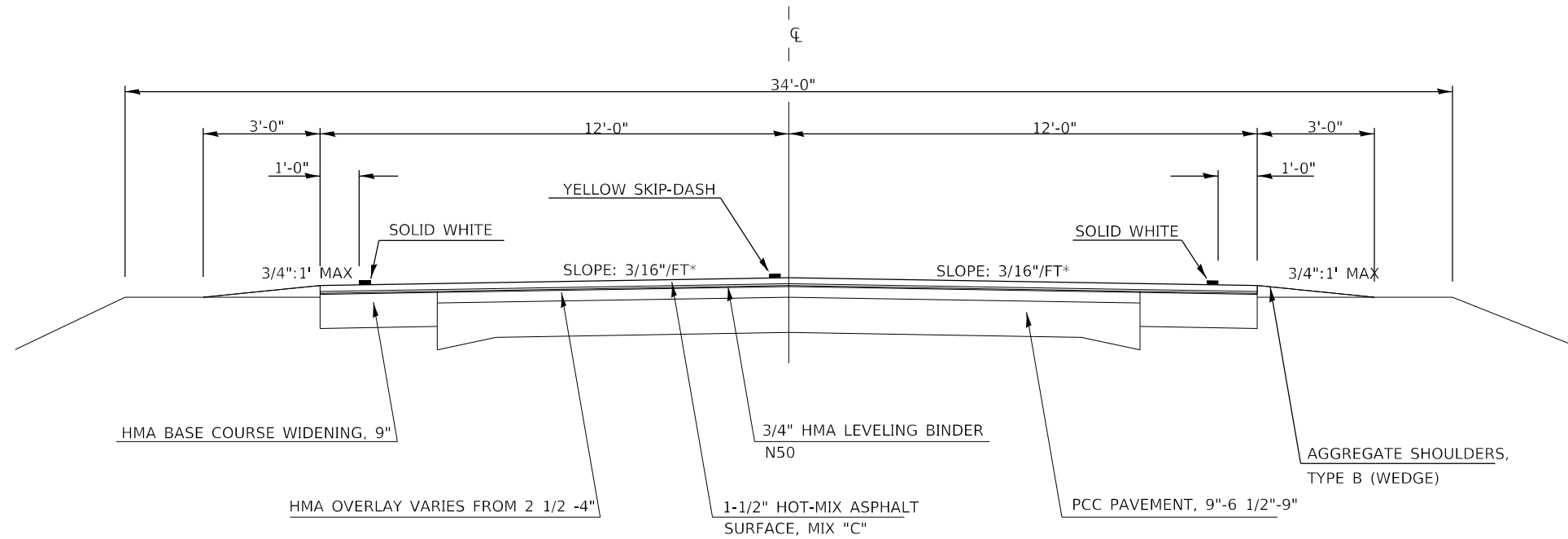

NOTE: * OMISSION STA 283+07.20 TO STA 339+08.08

STATION EQUATIONS:

STA 287+59.81 (BK) = STA 287+96.40 (AH)

STA 388+26.06 (BK) = STA 388+70.99 (AH)

NOTE: SUPERELEVATION STATIONS

281+96.40 TO 287+59.81 (BK)

382+16.00 TO 388+26.11 (BK)

1 PROPOSED TYPICAL SECTION

STATION	TO	STATION
244+00.00		302+15.00*
*328+63.00		401+82.60 (2)

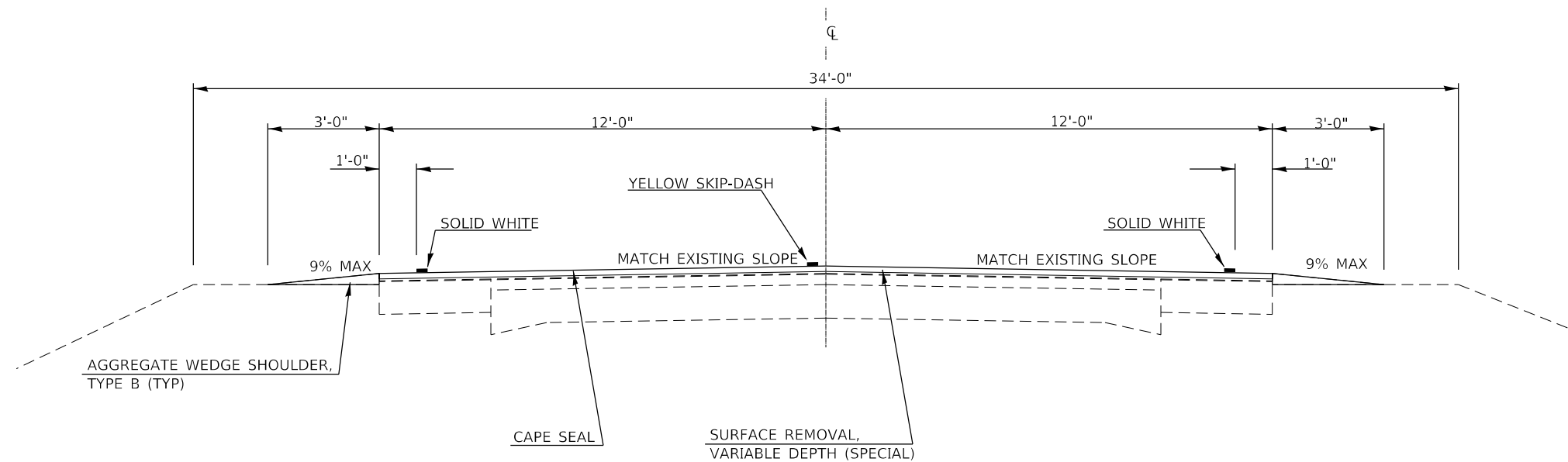

MODEL: Default
 FILE: \\mdele-prod\server\benfley.com\PHWDOT\Documents\DOT Offices\Bentley - S\Projects\0570603\CADD\DATA\CAD\Drawings\0570603-ah-typical.dgn

USER NAME = keysmj	DESIGNED -	REVISED -
	DRAWN -	REVISED -
PLOT SCALE = 100.0000' / in.	CHECKED -	REVISED -
PLOT DATE = 1/26/2022	DATE -	REVISED -

STATE OF ILLINOIS
DEPARTMENT OF TRANSPORTATION

EXISTING & PROPOSED TYPICAL CROSS SECTIONS
SCALE: NOT TO SCALE SHEET 1 OF 10 SHEETS STA. TO STA.

F.A.S. RTE.	SECTION	COUNTY	TOTAL SHEETS	SHEET NO.
2466	(9,10,11)RS-4, (9-1,9)RS-1	MCLEAN	45	6
CONTRACT NO. 70E03				
ILLINOIS FED. AID PROJECT				

B EXISTING TYPICAL SECTION

*STATION EQUATION:
 STA 403+73.39 (BK) = STA 411+11.00 (AH)
 STA 522+00.52 (BK) = STA 523+17.54 (AH)

* (A) $\frac{\text{STATION}}{401+82.60}$ TO $\frac{\text{STATION}}{560+07.00}$ (C)

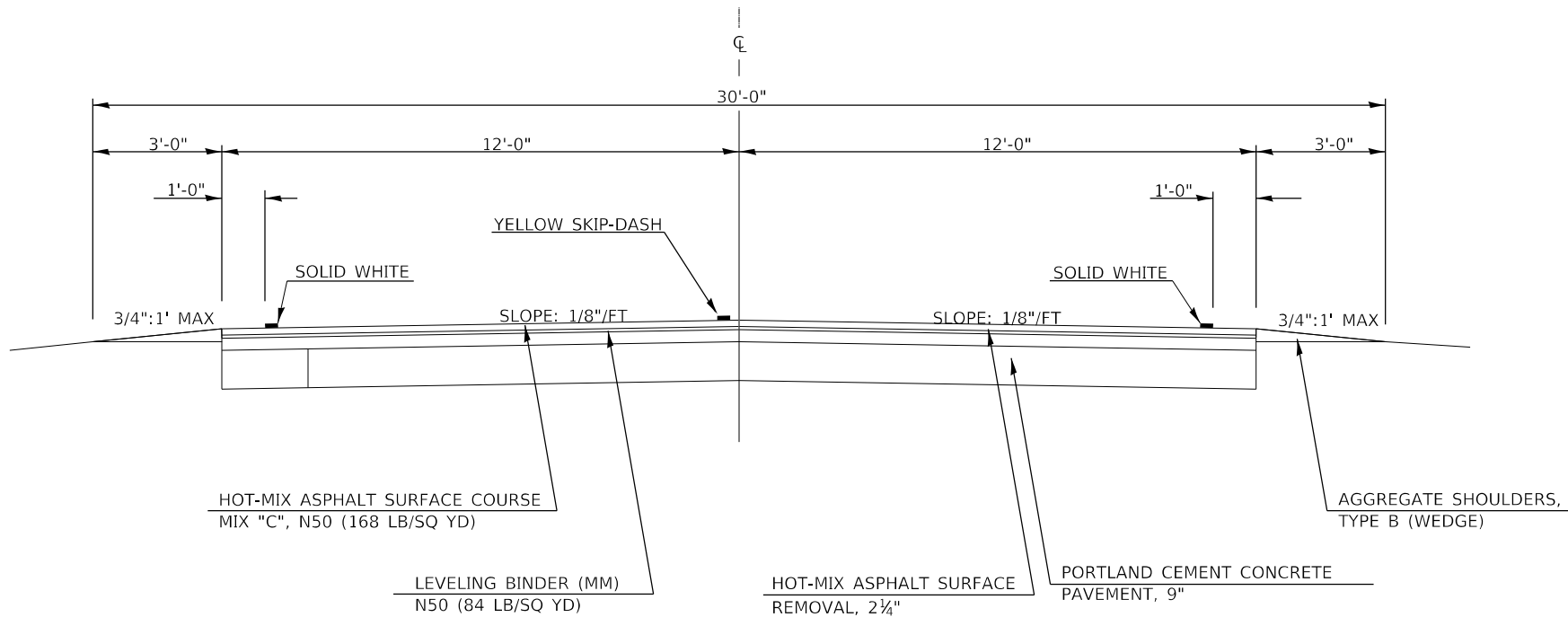

2 PROPOSED TYPICAL SECTION

*STATION EQUATION:
 STA 403+73.39 (BK) = STA 411+11.00 (AH)
 STA 522+00.52 (BK) = STA 523+17.54 (AH)

* (1) $\frac{\text{STATION}}{401+82.60}$ TO $\frac{\text{STATION}}{560+07.00}$ (3)

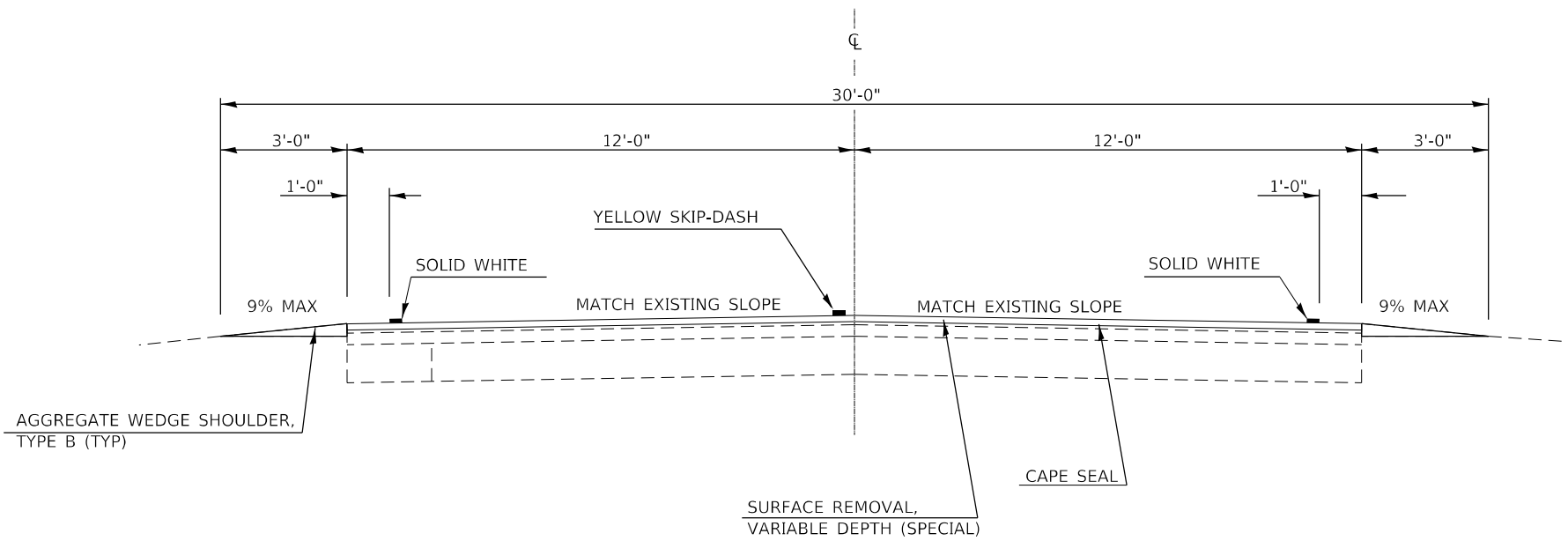

MODEL: Default
 FILE: \\mdele-pro\hides-cw\benfley.com\PHWDOT\Documents\DOT Offices\Bentley - S\Projects\0570603\CADD\Drawings\0570603-ah-typical.dgn

USER NAME = keysmj	DESIGNED -	REVISED -
PLOT SCALE = 100,0000' / in.	DRAWN -	REVISED -
PLOT DATE = 1/26/2022	CHECKED -	REVISED -
	DATE -	REVISED -

**STATE OF ILLINOIS
 DEPARTMENT OF TRANSPORTATION**

EXISTING & PROPOSED TYPICAL CROSS SECTIONS

SCALE: NOT TO SCALE SHEET 2 OF 10 SHEETS STA. TO STA.

F.A.S. RTE.	SECTION	COUNTY	TOTAL SHEETS	SHEET NO.
2466	(9,10,11)RS-4, (9-1,9)RS-1	MCLEAN	45	7
CONTRACT NO. 70E03				
ILLINOIS FED. AID PROJECT				

C EXISTING TYPICAL SECTION

*STATION EQUATION:
STA 567+18.16 (BK) = 256+00.77 (AH)

NOTE: STA DECREASING TOWARDS SOUTH

STATION TO STATION
* (B) 560+07.00 TO 567+18.16 (D)

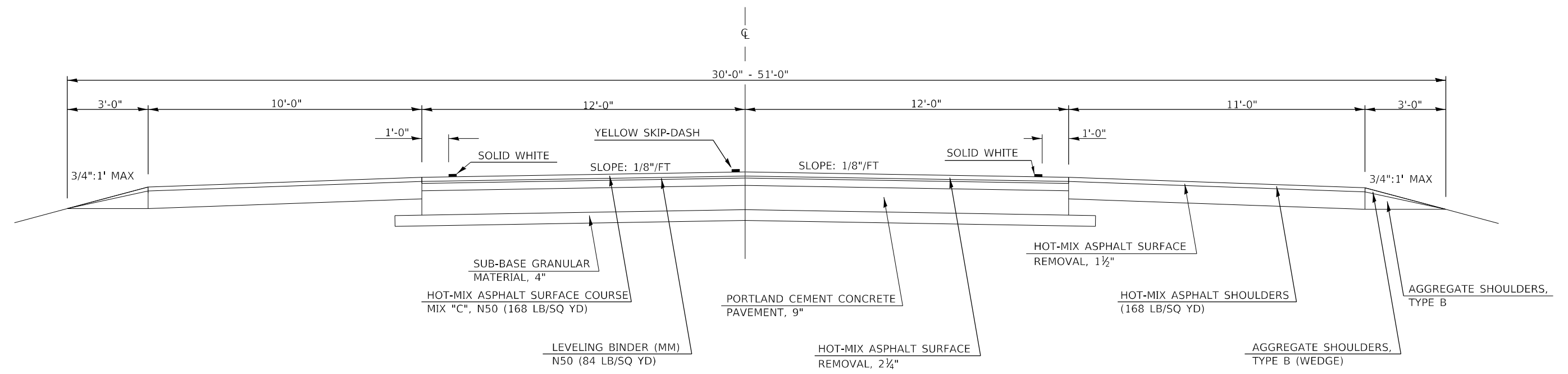

3 PROPOSED TYPICAL SECTION

*STATION EQUATION:
STA 567+18.16 (BK) = 256+00.77 (AH)

NOTE: STA DECREASING TOWARDS SOUTH

STATION TO STATION
* (2) 560+07.00 TO 567+18.16 (4)

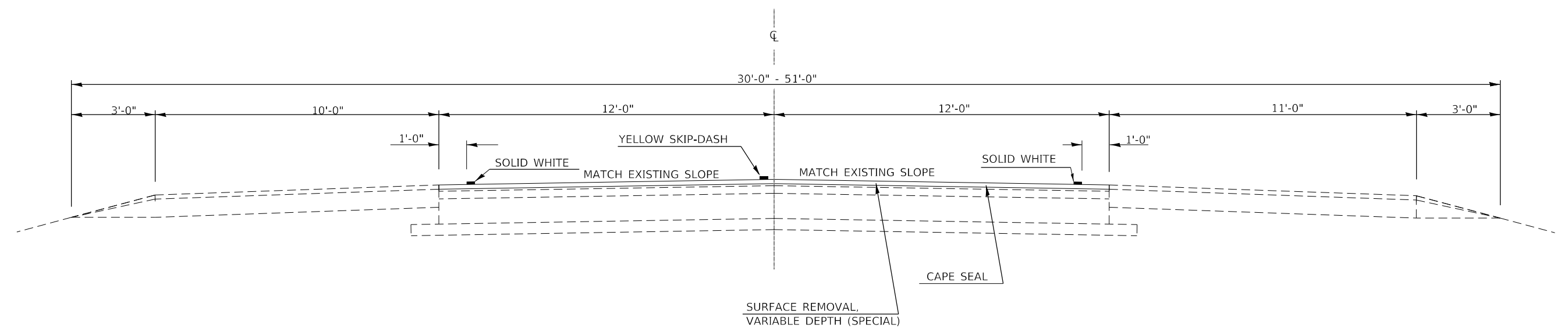

MODEL: Default
 FILE: \\mdele-prodfiles-cw.bentley.com:PHWD07\Documents\DOT Offices\Bentley\Projects\0570603\CADD\DATA\CAD\Revised\0570603-ah-typical.dgn

USER NAME = keysmj	DESIGNED -	REVISED -
	DRAWN -	REVISED -
PLOT SCALE = 100,0000 ' / in.	CHECKED -	REVISED -
PLOT DATE = 1/26/2022	DATE -	REVISED -

**STATE OF ILLINOIS
DEPARTMENT OF TRANSPORTATION**

EXISTING & PROPOSED TYPICAL CROSS SECTIONS

SCALE: NOT TO SCALE SHEET 3 OF 10 SHEETS STA. TO STA.

F.A.P. RTE.	SECTION	COUNTY	TOTAL SHEETS	SHEET NO.
676	(9,10,11)RS-4, (9-1,9)RS-1	MCLEAN	45	8
CONTRACT NO. 70E03				
ILLINOIS FED. AID PROJECT				

STRUCTURE OMISSION
 S.N. 057-0073: SBL/NBL
 *STA 239+19.16 TO 234+45.84

E EXISTING TYPICAL SECTION

	STATION	TO	STATION	
*	(D) 245+10.34		225+60.12	(F)
	(G) 213+63.84		208+27.22	(H)
	(G) 186+41.46		175+84.43	(I)

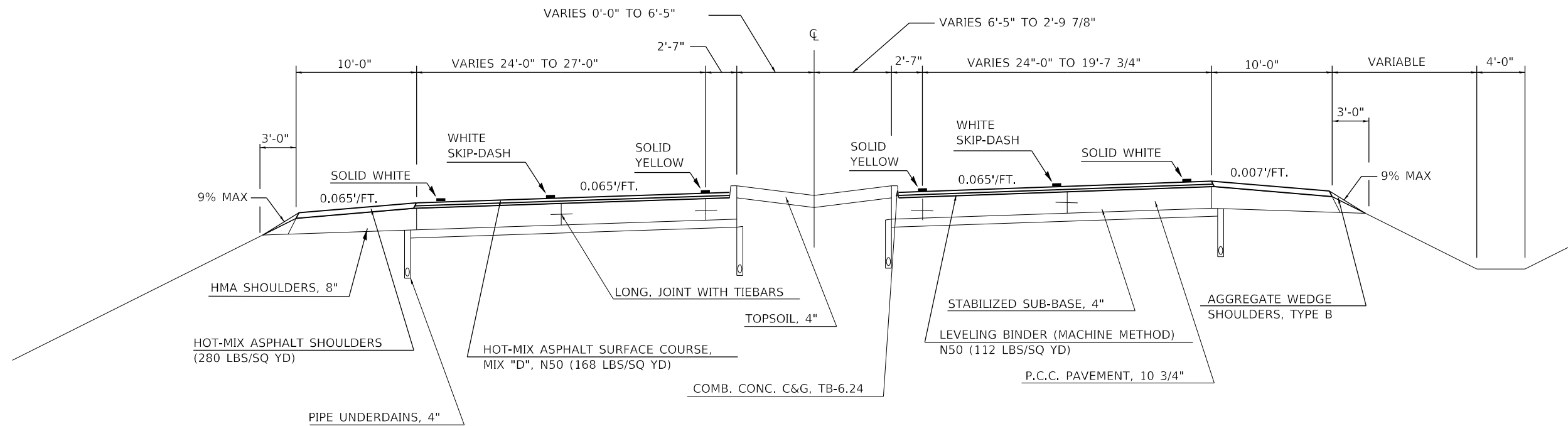

STRUCTURE OMISSION
 SN 057-0073 SBL/NBL
 *STA. 239+17.99 TO STA 234+47.47

5 PROPOSED TYPICAL SECTION

	STATION	TO	STATION	
*	(4) 245+10.34		225+60.12	(6)
	(7) 213+63.84		208+27.22	(8)
	(7) 186+41.46		175+84.43	(9)

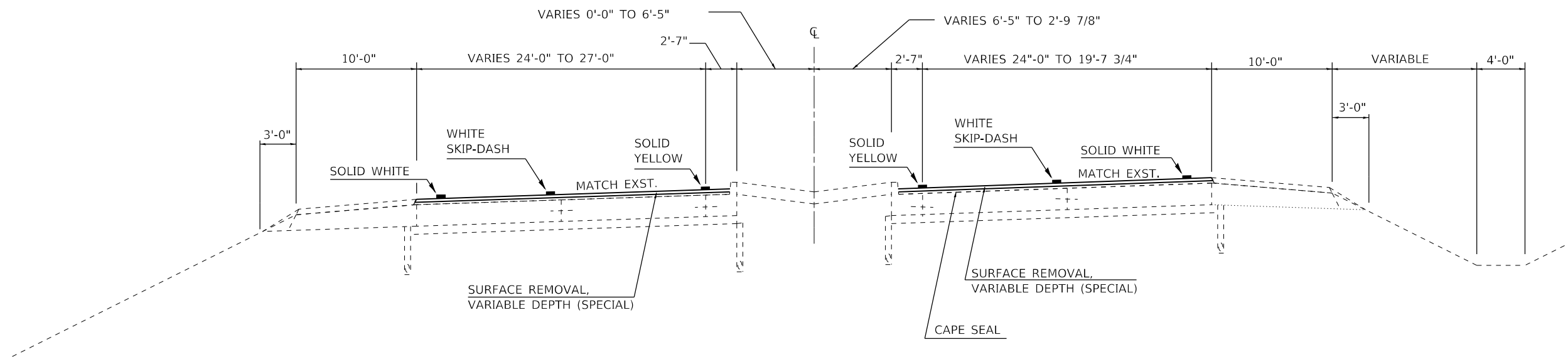

MODEL: Default
 FILE: \\mdele-prodfiles-cw-bentley.com\FWIDOT\Documents\DOT Offices\Bentley - S\Projects\0570603\CADD\DATA\CAD\Drawings\0570603-eh-typical.dgn

USER NAME = keysmj	DESIGNED -	REVISED -
	DRAWN -	REVISED -
PLOT SCALE = 100,0000' / in.	CHECKED -	REVISED -
PLOT DATE = 1/26/2022	DATE -	REVISED -

**STATE OF ILLINOIS
 DEPARTMENT OF TRANSPORTATION**

EXISTING & PROPOSED TYPICAL CROSS SECTIONS

SCALE: NOT TO SCALE | SHEET 5 OF 10 SHEETS | STA. TO STA.

F.A.P. RTE.	SECTION	COUNTY	TOTAL SHEETS	SHEET NO.
676	(9,10,11)RS-4, (9-1,9)RS-1	MCLEAN	45	10
CONTRACT NO. 70E03				
ILLINOIS FED. AID PROJECT				

(F) EXISTING TYPICAL SECTION

STATION TO STATION
 (E) 225+60.12 TO 218+09.32 (G)

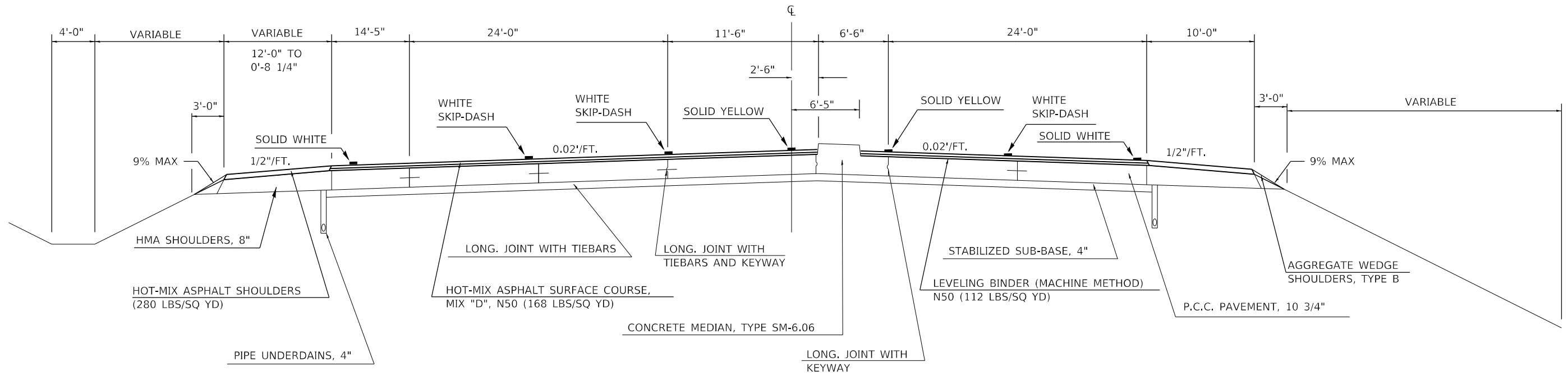

(6) PROPOSED TYPICAL SECTION

STATION TO STATION
 (5) 225+60.12 TO 218+09.32 (7)

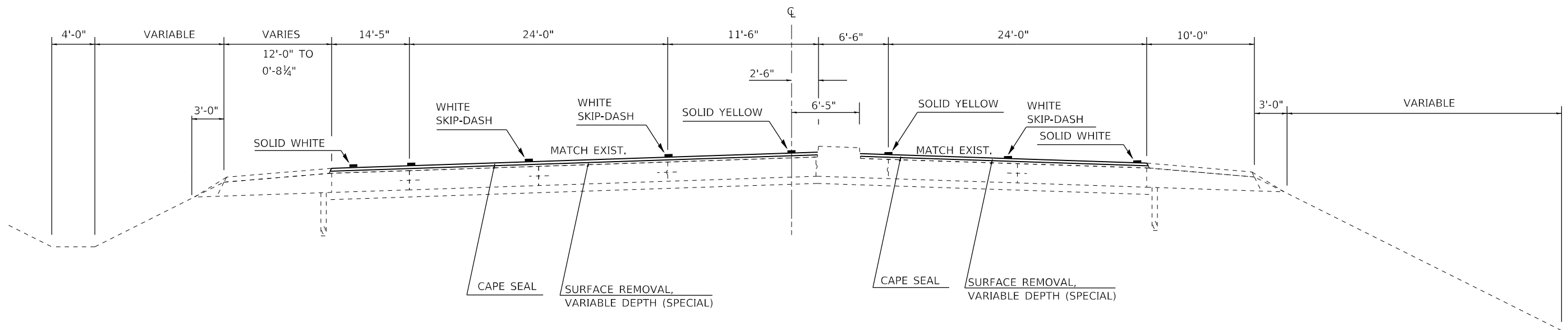

MODEL: Default
 FILE: Model - p:\projects\2022\70E03\CADD\Drawings\70E03-Sub-Typical.dgn
 PROJECT: 2022\70E03\CADD\Drawings\70E03-Sub-Typical.dgn

USER NAME = keysmj	DESIGNED -	REVISED -
	DRAWN -	REVISED -
PLOT SCALE = 100.0000' / in.	CHECKED -	REVISED -
PLOT DATE = 1/26/2022	DATE -	REVISED -

**STATE OF ILLINOIS
 DEPARTMENT OF TRANSPORTATION**

EXISTING & PROPOSED TYPICAL CROSS SECTIONS

SCALE: NOT TO SCALE SHEET 6 OF 10 SHEETS STA. TO STA.

F.A.P. RTE.	SECTION	COUNTY	TOTAL SHEETS	SHEET NO.
676	(9,10,11)RS-4, (9-1,9)RS-1	MCCLEAN	45	11
CONTRACT NO. 70E03				
ILLINOIS FED. AID PROJECT				

1

EXISTING TYPICAL SECTION

STATION TO STATION
 175+84.43 TO 168+37.67

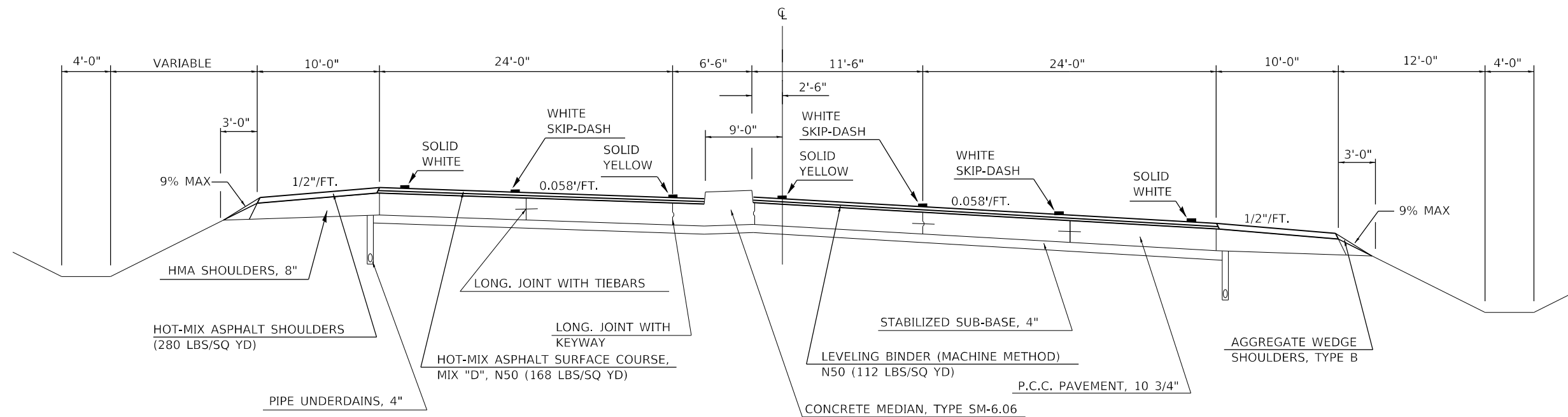

9

PROPOSED TYPICAL SECTION

STATION TO STATION
 175+84.43 TO 168+37.67

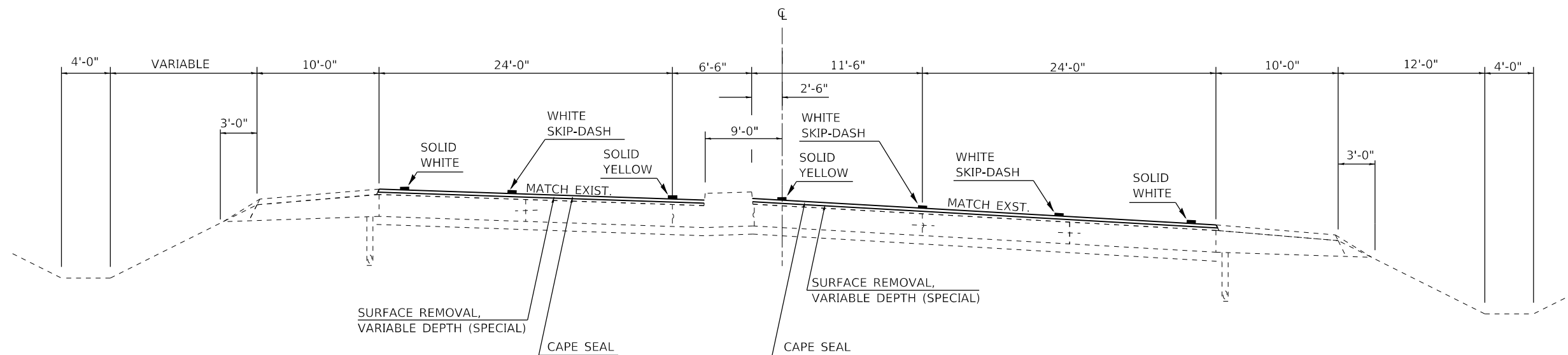

MODEL: Default
 FILE: \\nas01-pc01.bentley.com:PHWDOT\Documents\DOT Offices\Bentley - Projects\0570E03\CADD\Drawings\0570E03-9-1-1-1-1.dgn

USER NAME = keysmj	DESIGNED -	REVISED -
	DRAWN -	REVISED -
PLOT SCALE = 100.0000' / in.	CHECKED -	REVISED -
PLOT DATE = 1/26/2022	DATE -	REVISED -

**STATE OF ILLINOIS
 DEPARTMENT OF TRANSPORTATION**

EXISTING & PROPOSED TYPICAL CROSS SECTIONS

SCALE: NOT TO SCALE SHEET 9 OF 10 SHEETS STA. TO STA.

F.A.P. RTE.	SECTION	COUNTY	TOTAL SHEETS	SHEET NO.
676	(9,10,11)RS-4, (9-1,9)RS-1	MCLEAN	45	14
CONTRACT NO. 70E03				
ILLINOIS FED. AID PROJECT				

J

EXISTING TYPICAL SECTION

STATION 168+37.67 TO STATION 161+50.12

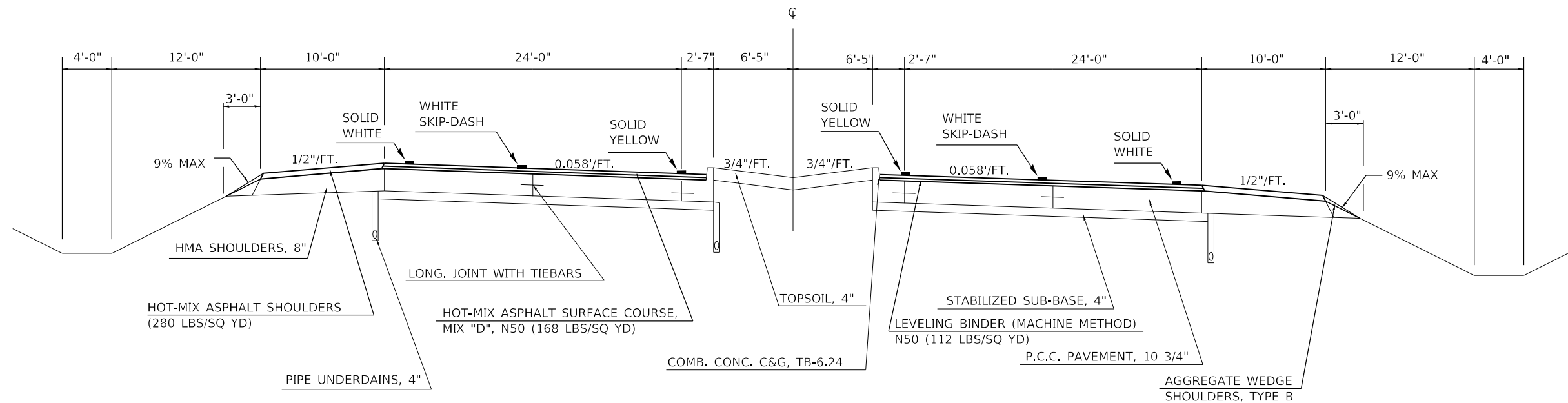

10

PROPOSED TYPICAL SECTION

STATION 168+37.67 TO STATION 161+50.12

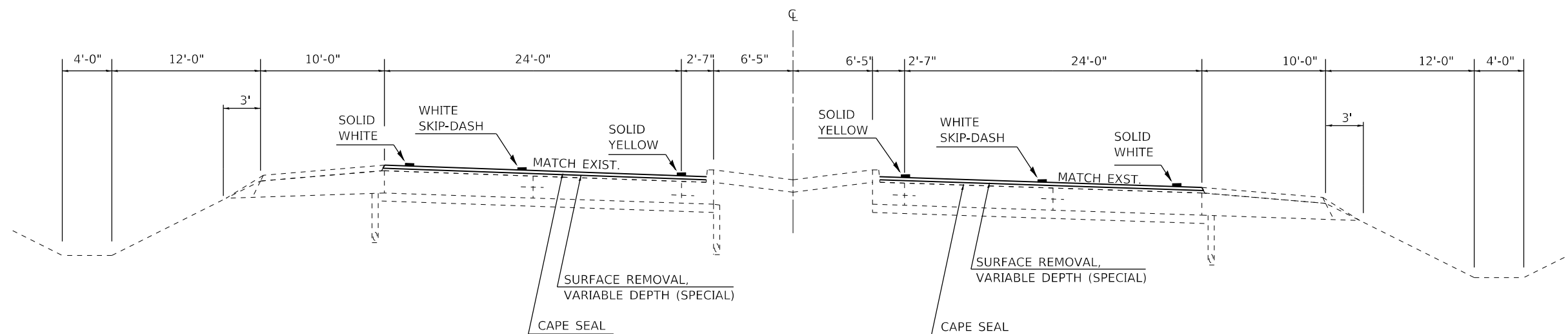

Model: Default
File: Main: p:\bldg-civ-bentley.com\pwwd\DOT\Documents\DOT Office\Drawings\Projects\0570603\CADD\Drawings\0570603-rt-typical.dgn

USER NAME = keysmj	DESIGNED -	REVISED -
	DRAWN -	REVISED -
PLOT SCALE = 100.0000' / in.	CHECKED -	REVISED -
PLOT DATE = 1/26/2022	DATE -	REVISED -

STATE OF ILLINOIS
DEPARTMENT OF TRANSPORTATION

EXISTING & PROPOSED TYPICAL CROSS SECTIONS

SCALE: NOT TO SCALE SHEET 10 OF 10 SHEETS STA. TO STA.

F.A.P. RTE.	SECTION	COUNTY	TOTAL SHEETS	SHEET NO.
676	(9,10,11)RS-4, (9-1,9)RS-1	MCLEAN	45	15
CONTRACT NO. 70E03				
ILLINOIS FED. AID PROJECT				

SCHEDULES OF QUANTITIES

CAPE SEAL, SURFACE REMOVAL, AND CRACK SEALING SCHEDULE

FAS 2466 (US 150 FROM WOODFORD CO LINE TO NORTH OF I-72)									40500061	X0326440	40400001
URBAN/ RURAL	LOC	STATION	TO	STATION	LENGTH (FT)	WIDTH (FT)	AREA (SQ YD)	CAPE SEAL (SQ YD)	SURFACE REMOVAL VAR DEPTH (SPECIAL) (SQ YD)	FIBER-MODIFIED ASPHALT CRACK SEALING (FT)**	
RURAL	NB	244+00.00		283+07.20	3,907.2	12.0	5,209.6	5,209.6	5,209.6	3,907.2	
RURAL	SB	244+00.00		283+07.20	3,907.2	12.0	5,209.6	5,209.6	5,209.6	3,907.2	
RURAL OMISSION STA 283+07.80 TO STA 339+08.08											
RURAL	NB	339+08.08		388+26.06	4,918.0	12.0	6,557.3	6,557.3	6,557.3	4,918.0	
RURAL	SB	339+08.08		388+26.06	4,918.0	12.0	6,557.3	6,557.3	6,557.3	4,918.0	
RURAL STA EQ 388+26.06 (BK) = 388+70.99 (AH)											
RURAL	NB	388+70.99		403+73.39	1,502.4	12.0	2,003.2	2,003.2	2,003.2	1,502.4	
RURAL	SB	388+70.99		403+73.39	1,502.4	12.0	2,003.2	2,003.2	2,003.2	1,502.4	
RURAL STA EQ 403+73.39 (BK) = 411+11.00 (AH)											
RURAL	NB	411+11.00		522+00.52	11,089.5	12.0	14,786.0	14,786.0	14,786.0	11,089.5	
RURAL	SB	411+11.00		522+00.52	11,089.5	12.0	14,786.0	14,786.0	14,786.0	11,089.5	
RURAL STA EQ 522+00.52 (BK) = 523+17.54 (AH)											
RURAL	NB	523+17.54		567+18.16	4,400.6	12.0	5,867.5	5,867.5	5,867.5	4,400.6	
RURAL	SB	523+17.54		567+18.16	4,400.6	12.0	5,867.5	5,867.5	5,867.5	4,400.6	
RURAL STA EQ 567+18.16 (BK) = 256+00.77 (AH)											
RURAL	NB	256+00.77		250+00.00	600.8	12.0	801.0	801.0	801.0	600.8	
RURAL	SB	256+00.77		250+00.00	600.8	12.0	801.0	801.0	801.0	600.8	
RURAL	NB	250+00.00		241+36.92	863.1	VAR	1,884.1	1,884.1	1,884.1	1,070.8	
RURAL	SB	250+00.00		241+36.92	863.1	VAR	2,196.8	2,196.8	2,196.8	1,257.0	
RURAL	NB	241+36.92		239+17.99	218.9	VAR	790.1	790.1	790.1	218.9	
RURAL	SB	241+36.92		239+17.99	218.9	VAR	607.6	607.6	607.6	218.9	
RURAL OMISSION SN 057-0003 FROM STA 239+17.99 TO STA 234+47.47											
SUB TOTAL:									75,927.9	75,927.9	55,001.9
FAP 676 (US 150 NORTH OF I-72 TO ILL 9)											
NORTHBOUND LANES											
*											
RURAL	NB	234+47.47		203+52.00	3,095.5	VAR	9,168.7	9,168.7	9,168.7	3,095.5	
URBAN	NB	203+52.00		195+95.00	757.0	VAR	3,425.7	3,425.7	3,425.7	757.0	
RURAL OMISSION SN 057-0202 FROM STA 195+95.00 TO STA 190+02.20											
URBAN	NB	190+02.20		42+19.65	14,782.6	VAR	47,299.0	47,299.0	47,299.0	14,782.6	
SOUTHBOUND LANES											
*											
RURAL OMISSION SN 057-0003 FROM STA 239+17.99 TO STA 234+47.47											
RURAL	SB	234+47.47		203+52.00	3,095.5	VAR	11,004.3	11,004.3	11,004.3	3,095.5	
URBAN	SB	203+52.00		196+41.24	710.8	VAR	2,001.8	2,001.8	2,001.8	710.8	
RURAL OMISSION SN 057-0202 FROM STA 196+41.24 TO STA 190+37.22											
URBAN	SB	190+37.22		42+19.65	14,817.6	VAR	46,976.6	46,976.6	46,976.6	14,817.6	
SUB TOTAL:									119,876.1	119,876.1	37,258.8
RURAL TOTAL:									81,506.7	81,506.7	56,414.4
URBAN TOTAL:									114,297.3	114,297.3	35,846.3
TOTAL:									195,804.0	195,804.0	92,260.7
USE TOTAL:									195,804.0	195,804.0	92,260.0

* FAP 676 PAVEMENT AREA MEASURED FROM CADD

**CENTERLINE APPLICATION

AGGREGATE WEDGE SHOULDER, TYPE B SCHEDULE

								48102100
LOCATION	STATION	TO	STATION	LENGTH (FT)	WIDTH (FT)	AVE HEIGHT (FT)	VOLUME (CU YD)	AGGREGATE WEDGE SHOULDER, TYPE B (TON)
NB	244+00.00		283+07.20	3,907.20	3	0.167	72.50	130.50
SB	244+00.00		283+07.20	3,907.20	3	0.167	72.50	130.50
RURAL OMISSION STA 283+07.80 TO STA 339+08.08								
NB	339+08.08		388+26.06	4,917.98	3	0.167	91.26	164.26
SB	339+08.08		388+26.06	4,917.98	3	0.167	91.26	164.26
RURAL STA EQ 388+26.06 (BK) = 388+70.99 (AH)								
NB	388+70.99		403+73.39	1,502.40	3	0.167	27.88	50.18
SB	388+70.99		403+73.39	1,502.40	3	0.167	27.88	50.18
RURAL STA EQ 403+73.39 (BK) = 411+11.00 (AH)								
NB	411+11.00		522+00.52	11,089.52	3	0.167	205.77	370.39
SB	411+11.00		522+00.52	11,089.52	3	0.167	205.77	370.39
RURAL STA EQ 522+00.52 (BK) = 523+17.54 (AH)								
NB	523+17.54		560+10.00	3,692.46	3	0.167	68.52	123.33
SB	523+17.54		560+10.00	3,682.46	3	0.167	68.33	122.99
RURAL TOTAL:								1,677.00
URBAN TOTAL:								0.00
TOTAL:								1,677.0
USE TOTAL:								1,677.0

NOTE: AGGREGATE SHOULDERS PLACED PRIOR TO MICROSURFACING

BUMP REMOVAL SCHEDULE

		40400020
LOCATION		BUMP REMOVAL (EACH)
FAS 2466 (NB&SB)		75
FP 676 (NB&SB)		75
RURAL TOTAL:		85
URBAN TOTAL:		65
TOTAL:		150
USE TOTAL:		150

NOTE: LOCATION TO BE FIELD VERIFIED BY ENGINEER

MODEL - S:\MODELS\MAMES FILE - 040422 - ILLINOIS DOT\Documents\DOT Office\Illinois DOT\Projects\057003\CADD\Drawings\057003-01-Schedules of Quantities.dgn

USER NAME = monjardnrrt	DESIGNED -	REVISED -	STATE OF ILLINOIS DEPARTMENT OF TRANSPORTATION	SCHEDULES OF QUANTITIES	SECTION	COUNTY	TOTAL SHEETS	SHEET NO.	
PLOT SCALE = 40,0462' / in.	DRAWN -	REVISED -			(9,10,11)RS-4,(9-1,9)RS-1	MCLEAN	45	16	
PLOT DATE = 3/10/2022	CHECKED -	REVISED -			*FAS 2466 & FAP 676 (US 150)		CONTRACT NO. 70E03		
	DATE -	REVISED -			ILLINOIS FED. AID PROJECT				

SCALE: NONE SHEET 1 OF 7 SHEETS STA. TO STA.

SCHEDULES OF QUANTITIES

PAVEMENT MARKING SCHEDULE

FAS 2466 (US 150 FROM WOODFORD CO LINE TO I-72)

URBAN/ RURAL	STATION	TO	STATION	LENGTH (FT)	CL LINE TYPE	COLOR	70300221			78300202 PAVEMENT MARKING REMOVAL WATERBLASTING (SQ FT)	70300100 SHORT TERM PAVEMENT MARKING* (FT)	70300150 SHORT TERM PAVEMENT MARKING REMOVAL** (SQ FT)		
							TEMPORARY PAVEMENT MARKING LINE 4"- PAINT	CENTERLINE SKIP DASH (FT)	CENTERLINE SOLID YELLOW (FT)				EDGE LINES SOLID WHITE (FT)	
RURAL	244+00.00		283+07.20	3,907.2	SKIP DASH	YELLOW	976.8		7,814.4	2,901.1	1,562.9	128.9		
<i>OMISSION STA 283+07.80 TO STA 339+08.08</i>														
RURAL	339+08.08		384+00.00	4,491.9	SINGLE SOLID	YELLOW		4,491.9	8,983.8	4,447.0	1,796.8	148.2		
RURAL	384+00.00		388+00.00	400.0	DOUBLE YELLOW	YELLOW		800.0	800.0	528.0	160.0	13.2		
RURAL	388+00.00		388+26.06	26.1	SINGLE SOLID	YELLOW	6.5		52.1	19.3	10.4	0.9		
<i>STA EQ 388+26.06 (BK) = 388+70.99 (AH)</i>														
RURAL	388+70.99		403+73.39	1,502.4	SINGLE SOLID	YELLOW		1,502.4	3,004.8	1,487.4	601.0	49.6		
<i>STA EQ 403+73.39 (BK) = 411+11.00 (AH)</i>														
RURAL	411+11.00		414+16.20	305.2	SINGLE SOLID	YELLOW		305.2	610.4	302.1	122.1	10.1		
RURAL	414+16.20		423+61.00	944.8	SKIP DASH	YELLOW	236.2		1,889.6	701.5	377.9	31.2		
RURAL	423+61.00		430+50.00	689.0	DOUBLE YELLOW	YELLOW		1,378.0	1,378.0	909.5	275.6	22.7		
RURAL	430+50.00		435+20.08	470.1	SINGLE SOLID	YELLOW		470.1	940.2	465.4	188.0	15.5		
RURAL	435+20.08		443+15.08	795.0	SKIP DASH	YELLOW	198.8		1,590.0	590.3	318.0	26.2		
RURAL	443+15.08		451+65.08	850.0	SINGLE SOLID	YELLOW		850.0	1,700.0	841.5	340.0	28.1		
RURAL	451+65.08		456+35.08	470.0	DOUBLE YELLOW	YELLOW		940.0	940.0	620.4	188.0	15.5		
RURAL	456+35.08		464+35.08	800.0	SINGLE SOLID	YELLOW		800.0	1,600.0	792.0	320.0	26.4		
RURAL	464+35.08		504+35.08	4,000.0	SKIP DASH	YELLOW	1,000.0		8,000.0	2,970.0	1,600.0	132.0		
RURAL	504+35.08		509+77.08	542.0	SINGLE SOLID	YELLOW		542.0	1,084.0	536.6	216.8	17.9		
RURAL	509+77.08		511+16.08	139.0	SKIP DASH	YELLOW	34.8		278.0	103.2	55.6	4.6		
RURAL	511+16.08		517+21.08	605.0	SINGLE SOLID	YELLOW		605.0	1,210.0	599.0	242.0	20.0		
RURAL	517+21.08		522+00.52	479.4	SKIP DASH	YELLOW	119.9		958.9	356.0	191.8	15.8		
<i>STA EQ 522+00.52 (BK) = 523+17.54 (AH)</i>														
RURAL	523+17.54		567+18.16	4,400.6	SKIP DASH	YELLOW	1,100.2		8,801.2	3,267.5	1,760.2	145.2		
<i>STA EQ 567+18.16 (BK) = 256+00.77 (AH)</i>							SUB-TOTAL 1 FAS 2466:	3,673.0	12,684.6	51,635.4	22,437.7	10,327.1	852.0	
							TOTAL PAINT PAVEMENT MARKING- LINE 4":			67,993.1				
									USE TOTAL:			67,993.0		

NOTE: PAINT PAVEMENT MARKING 4" APPLIED AT FAS 2466 ONLY, FROM STA 244+00 TO STA 567+18.16

* 3 PAINT APPLICATIONS AT CL ONLY- MILLED SURFACE, AFTER CL CRACK CONTROL, & A1 SURFACE,

1 APPLICATION OF TAPE FOR SHORT TERM PAVEMENT MARKING ON MICROSURFACING

** REMOVAL OF TAPE ON MICROSURFACING ONLY, NO REMOVAL OF SHORT TERM PVT MARKING PAINT ON LIFTS

FAS 2466 (US 150 FROM WOODFORD CO LINE TO NORTH OF I-72)

URBAN/ RURAL	STATION	TO	STATION	LENGTH (FT)	LINE TYPES	70300221				70300100			70300150	78300202	
						TEMPORARY PAVEMENT MARKING LINE 4"- PAINT	CENTERLINE SKIP DASH (FT)	EDGE LINE WHITE (FT)	EDGE LINE YELLOW (FT)	TURN Lanes WHITE (FT)	SHORT TERM PAVEMENT MARKING* (FT)	SHORT TERM PAVEMENT MARKING ** (FT)	SHORT TERM PAVEMENT MARKING REMOVAL (SQ FT)***	PAVEMENT MARKING REMOVAL WATERBLASTING (SQ FT)	
GROOVING FOR RECESSED PAVEMENT MARKING 5" (FOOT)															
78000200															
THERMOPLASTIC PAVEMENT MARKING - LINE 4"															
						CL & TURN LANE	SHOULDERS	MICRO SURFACING							
						(FT)	(FT)	(FT)	(FT)	(FT)	(FT)	(SQ FT)***	(SQ FT)		
NORTHBOUND LANE															
RURAL	256+00.77		248+59.00	741.8	CL & EDGE LINE	185.4	741.8	741.8		222.5	14.8	74.2	29.4	550.8	
RURAL	248+59.00		241+36.92	722.1	CL & EDGE LINE	180.5	722.1	722.1		216.6	14.4	72.2	28.6	536.1	
RURAL	241+36.92		241+00.00	36.9	CL & EDGE LINE	9.2	36.9	36.9		11.1	0.7	3.7	1.5	27.4	
RURAL	241+00.00		239+17.99	182.0	CL & EDGE LINE	45.5	182.0	182.0		54.6	3.6	18.2	7.2	135.1	
SOUTHBOUND LANE															
RURAL	248+59.00		241+36.92	722.1	CL & EDGE LINE	180.5	722.1	722.1		216.6	14.4	72.2	28.6	536.1	
RURAL	241+36.92		239+17.99	218.9	CL & EDGE LINE	54.7	218.9	218.9		65.7	4.4	21.9	8.7	162.6	
						601.2	2,404.9	2,404.9						1,785.6	
						SUB TOTAL 2 FAS 2456	5,410.9	787.1	52.5	262.4	103.9	3,733.8			
						TOTAL FAS 2456	5,410.9			11,429.1	955.9	26,171.5			

*** SHORT TERM MARKING REMOVAL ON TAPE ON MICROSURFACING AND DIAGONAL MARKINGS ON SHOULDERS ONLY

(SHORT TERM PAVEMENT MARKING & REMOVAL SCHEDULE FOR FAP 676 CONTINUED NEXT SHEET)

MODEL: \$MDELMNAMES
 FILE: \\miller\pub\miller\benben\com\p\WID01\Documents\DOT Offices\dot\dot\p\Projects\05201033\CAD\Draws\CAD\Sheet05201033\sh-Schedules of Quantities.dgn

USER NAME = monjardinrt	DESIGNED -	REVISED -
	DRAWN -	REVISED -
PLOT SCALE = 40,0316 ' / in.	CHECKED -	REVISED -
PLOT DATE = 3/10/2022	DATE -	REVISED -

**STATE OF ILLINOIS
DEPARTMENT OF TRANSPORTATION**

SCHEDULES OF QUANTITIES

SCALE: NONE SHEET 2 OF 7 SHEETS STA. TO STA.

F.A. RTE.	SECTION	COUNTY	TOTAL SHEETS	SHEET NO.
*	(9,10,11)RS-4,(9-1)RS-1	MCLEAN	45	17
*FAS 2466 & FAP 676 (US 150)		CONTRACT NO. 70E03		
ILLINOIS FED. AID PROJECT				

SCHEDULES OF QUANTITIES

PAVEMENT MARKING SCHEDULE (CONTINUED)

FAP 676 (US 150-- I-72 TO ILL 9)
NORTHBOUND LANE

URBAN/ RURAL	STATION	TO	STATION	LENGTH (FT)	LINE TYPES	70300221 TEMPORARY PAVEMENT MARKING LINE 4"- PAINT				78011025 GROOVING FOR RECESSED PAVEMENT MARKING 5" (FOOT)			78000200 THERMOPLASTIC PAVEMENT MARKING - LINE 4"			70300100			70300150	78300202
						CENTERLINE	EDGE LINE	EDGE LINE	TURN LANES	SKIP DASH	WHITE	YELLOW	WHITE	SHORT TERM PAVEMENT MARKING*	SHORT TERM PAVEMENT MARKING **		SHORT TERM PAVEMENT MARKING REMOVAL	PAVEMENT MARKING REMOVAL WATERBLASTING		
						(FT)	(FT)	(FT)	(FT)	(FT)	(FT)	(FT)	(FT)	(FT)	(FT)	(FT)	(SQ FT)***	(SQ FT)		
RURAL	238+00.00		231+20.00	680.0	CL & EDGE LINE	170.0	680.0	680.0		204.0	13.6	68.0				26.9	504.9			
RURAL	231+20.00		228+90.00	230.0	CL, EDGE, & TL	57.5	230.0	230.0	230.0	138.0	4.6	23.0				9.1	246.7			
RURAL	228+90.00		204+00.00	2,490.0	CL & EDGE LINE	622.5	2,490.0	2,490.0		747.0	49.8	249.0				98.6	1,848.8			
RURAL	204+00.00		203+52.00	48.0	CL, EDGE, & TL (2)	12.0	48.0	48.0	96.0	28.8	1.0	4.8				1.9	67.3			
URBAN	203+52.00		199+20.00	432.0	CL, EDGE, & TL (2)	108.0	432.0	432.0	844.9	259.2	8.6	43.2				17.1	599.6			
URBAN	199+20.00		173+00.00	2,620.0	CL & EDGE LINE	655.0	2,620.0	2,620.0		758.7	52.4	262.0				103.8	1,945.4			
URBAN	173+00.00		168+00.00	500.0	CL, EDGE, & TL	125.0	500.0	500.0	500.0	300.0	10.0	50.0				19.8	536.3			
URBAN	168+00.00		150+00.00	1,800.0	CL & EDGE LINE	450.0	1,800.0	1,800.0		540.0	36.0	180.0				71.3	1,336.5			
URBAN	150+00.00		147+70.00	230.0	CL, EDGE, & TL	57.5	230.0	230.0	230.0	138.0	4.6	23.0				9.1	246.7			
URBAN	147+70.00		139+00.00	870.0	CL & EDGE LINE	217.5	870.0	870.0		261.0	17.4	87.0				34.5	646.0			
URBAN	139+00.00		136+90.00	210.0	CL, EDGE, & TL	52.5	210.0	210.0	210.0	126.0	4.2	21.0				8.3	225.2			
URBAN	136+90.00		126+20.00	1,070.0	CL & EDGE LINE	267.5	1,070.0	1,070.0		321.0	21.4	107.0				42.4	794.5			
URBAN	126+20.00		122+10.00	410.0	CL, EDGE, & TL	102.5	410.0	410.0	410.0	246.0	8.2	41.0				16.2	399.8			
URBAN	122+10.00		118+00.00	410.0	CL & EDGE LINE	102.5	410.0	410.0		123.0	8.2	41.0				16.2	276.8			
URBAN	118+00.00		116+10.00	190.0	CL, EDGE, & TL	47.5	190.0	190.0	190.0	114.0	3.8	19.0				7.5	203.8			
URBAN	116+10.00		104+00.00	1,210.0	CL & EDGE LINE	302.5	1,210.0	1,210.0		363.0	24.2	121.0				47.9	816.8			
URBAN	104+00.00		100+00.00	400.0	CL, EDGE, & TL	100.0	400.0	400.0	400.0	240.0	8.0	40.0				15.8	390.0			
URBAN	100+00.00		69+00.00	3,100.0	CL & EDGE LINE	775.0	3,100.0	3,100.0		902.7	62.0	310.0				122.8	2,092.5			
URBAN	69+00.00		65+20.00	380.0	CL, EDGE, & TL	95.0	380.0	380.0	380.0	228.0	7.6	38.0				15.0	370.5			
URBAN	65+20.00		51+50.00	1,370.0	CL & EDGE LINE	342.5	1,370.0	1,370.0		411.0	27.4	137.0				54.3	924.8			
URBAN	51+50.00		46+70.00	480.0	CL, EDGE, & TL	120.0	480.0	480.0	480.0	288.0	9.6	48.0				19.0	468.0			
URBAN	46+70.00		42+19.65	450.4	CL & EDGE LINE	112.6	450.4	450.4		135.1	9.0	45.0				17.8	304.0			
						4,895.1	19,580.4	19,580.4	3,970.9	6,872.5	391.6	1,958.0	775.4	775.4	15,244.5					
						SUB-TOTAL NB FAP 676:			48,026.7				9,222.1	775.4	15,244.5					

NOTE: THERMOPLASTIC 4" & GROOVING APPLIED AT FAP 676 ONLY, FROM STA 256+00.77 TO STA 42+19.65

* 3 PAINT APPLICATIONS AT CL AND TURN LANES ONLY, PAINT APPLIED ON MILLED SURFACE, AFTER CL CRACK CONTROL, & A1 SURFACE

** 1 APPLICATION OF TAPE, TO BE USED ON PAVED SHOULDERS AND MICROSURFACING

*** SHORT TERM MARKING REMOVAL ON TAPE ON MICROSURFACING AND DIAGONAL MARKINGS ON SHOULDERS ONLY

(FAP 676 SOUTHBOUND LANE SCHEDULE CONTINUED ON NEXT SHEET)

MODEL: S:\MODEL\NAMES
FILE NAME: p:\illinois\pww\dot\Documents\DOT Offices\District 3\Projects\0570103\CAD\03a\03a\03a\Schedules of Quantities.dgn

USER NAME = monjardnrt	DESIGNED -	REVISED -
	DRAWN -	REVISED -
PLOT SCALE = 40,2793 ' / in.	CHECKED -	REVISED -
PLOT DATE = 3/10/2022	DATE -	REVISED -

**STATE OF ILLINOIS
DEPARTMENT OF TRANSPORTATION**

SCHEDULES OF QUANTITIES

SCALE: NONE SHEET 3 OF 7 SHEETS STA. TO STA.

F.A. RTE.	SECTION	COUNTY	TOTAL SHEETS	SHEET NO.
*	(9,10,11)RS-4,(9-1,9)RS-1	MCLEAN	45	18
*FAS 2466 & FAP 676 (US 150)		CONTRACT NO. 70E03		
ILLINOIS FED. AID PROJECT				

SCHEDULES OF QUANTITIES

RAISED REFLECTIVE PAVEMENT MARKER SCHEDULE

FAS 2466 (US 150 FROM WOODFORD CO LINE TO NORTH OF I-72)

URBAN/ RURAL	STATION	TO	STATION	LENGTH (FT)	78100100	78300200
					RAISED REFLECTIVE PAVEMENT MARKER (EACH)	RAISED REFLECTIVE PAVEMENT MARKER REMOVAL (EACH)
RURAL	244+00.00		282+00.00	3,800.0	48.0	48.0
RURAL *	282+00.00		285+00.00	300.0	12.0	12.0
<i>CAPE SEAL OMISSION STA 283+07.80 TO STA 339+08.08</i>					0.0	0.0
RURAL	339+08.08		382+00.00	4,291.9	54.0	54.0
RURAL *	382+00.00		388+26.00	626.0	39.0	39.0
<i>STA EQ 388+26.06 (BK) = 388+70.99 (AH)</i>					0.0	0.0
RURAL	388+70.99		403+73.39	1,502.4	19.0	19.0
<i>STA EQ 403+73.39 (BK) = 411+11.00 (AH)</i>						
RURAL	411+11.00		414+16.20	305.2	4.0	4.0
RURAL	414+16.20		423+61.00	944.8	12.0	12.0
RURAL	423+61.00		430+50.00	689.0	9.0	9.0
RURAL	430+50.00		435+20.08	470.1	6.0	6.0
RURAL	435+20.08		443+15.08	795.0	10.0	10.0
RURAL	443+15.08		451+65.08	850.0	11.0	11.0
RURAL	451+65.08		456+35.08	470.0	6.0	6.0
RURAL	456+35.08		464+35.08	800.0	10.0	10.0
RURAL	464+35.08		504+35.08	4,000.0	50.0	50.0
RURAL	504+35.08		509+77.08	542.0	7.0	7.0
RURAL	509+77.08		511+16.08	139.0	2.0	2.0
RURAL	511+16.08		517+21.08	605.0	8.0	8.0
RURAL	517+21.08		522+00.52	479.4	6.0	6.0
<i>STA EQ 522+00.52 (BK) = 523+17.54 (AH)</i>					0.0	0.0
RURAL	523+17.54		567+18.16	4,400.6	55.0	55.0
<i>STA EQ 567+18.16 (BK) = 256+00.77 (AH)</i>						
RURAL - NB&SB	256+45.00		248+00.00	845.0	11	11
RURAL-NB	248+00.00		241+36.92	663.1	7	7
RURAL-SB	248+00.00		241+36.92	663.1	7	7
RURAL-NB	241+36.92		239+19.16	217.8	3	3
RURAL-SB	241+36.92		239+19.16	217.8	3	3
RURAL-NB	239+92.90		237+82.70	210.2	4	4
SUB-TOTAL FAS 2466:					403.0	403.0

* CURVE SECTION--CL AT 80 FT SPACING & 40 FT RPRM SPACING ON BOTH SIDES OF PAVEMENT EDGE

RAISED REFLECTIVE PAVEMENT MARKER SCHEDULE (CONTINUED)

FAP 676 (US 150 NORTH OF I-72 TO ILL 9)

URBAN/ RURAL	DIRECTION	STATION	TO	STATION	78100100	78300200
					RAISED REFLECTIVE PAVEMENT MARKER EACH	RAISED REFLECTIVE PAVEMENT MARKER REMOVAL EACH
RURAL	SB	235+42.60		232+87.00	8	8
RURAL	NB	231+03.00		229+30.00	4	4
RURAL	SB	234+45.84		221+00.00	17	17
SUB-TOTAL FAP 676:					29	29

RAISED REFLECTIVE PAVEMENT MARKER SCHEDULE (CONTINUED)

FAP 676 (US 150 NORTH OF I-72 TO ILL 9)

URBAN/ RURAL	DIRECTION	STATION	TO	STATION	78100100	78300200
					RAISED REFLECTIVE PAVEMENT MARKER	RAISED REFLECTIVE PAVEMENT MARKER REMOVAL
RURAL	NB	234+45.84		221+00.00	17	17
RURAL	SB	221+87.50		220+81.50	3	3
RURAL	SB	222+82.00		220+81.50	5	5
RURAL	SB	221+00.00		206+00.00	19	19
RURAL	NB	221+00.00		206+00.00	19	19
URBAN	SB	206+00.00		206+50.94	2	2
URBAN	NB	206+00.00		204+51.28	2	2
URBAN	SB	205+67.50		204+04.00	4	4
URBAN	SB	202+98.80		200+40.80	6	6
URBAN	NB	202+98.80		200+40.80	6	6
URBAN	SB	202+57.15		196+42.10	8	8
URBAN	NB	202+71.03		195+96.00	8	8
URBAN	SB	190+39.00		176+00.00	18	18
URBAN	NB	189+93.00		176+00.00	17	17
URBAN	NB	171+87.00		169+77.00	5	5
URBAN	NB	176+00.00		161+00.00	19	19
URBAN	NB	176+00.00		161+00.00	19	19
URBAN	SB	152+16.70		150+12.70	5	5
URBAN	NB	148+49.90		147+67.90	2	2
URBAN	SB	161+00.00		146+00.00	19	19
URBAN	NB	161+00.00		146+00.00	19	19
URBAN	SB	131+00.00		127+32.70	5	5
URBAN	NB	131+00.00		127+32.70	5	5
URBAN	SB	129+02.50		127+05.50	5	5
URBAN	NB	126+07.00		123+41.00	7	7
URBAN	NB	117+19.00		116+33.00	2	2
URBAN	SB	125+91.47		116+00.00	12	12
URBAN	NB	125+91.47		116+00.00	12	12
URBAN	NB	116+00.00		105+42.39	13	13
URBAN	SB	116+00.00		105+42.39	13	13
URBAN	SB	107+17.00		105+09.00	5	5
URBAN	SB	103+97.66		101+00.00	4	4
URBAN	NB	104+10.00		101+34.00	7	7
URBAN	NB	103+97.66		101+00.00	4	4
URBAN	NB	101+00.00		86+00.00	19	19
URBAN	SB	101+00.00		86+00.00	19	19
URBAN	SB	98+90.00		96+57.00	6	6
URBAN	SB	86+00.00		71+00.00	19	19
URBAN	SB	74+00.00		73+20.00	2	2
URBAN	NB	86+00.00		71+00.00	19	19
URBAN	SB	71+32.00		69+17.00	5	5
URBAN	NB	68+10.70		66+00.70	5	5
URBAN	SB	61+49.70		59+38.70	5	5
URBAN	SB	71+00.00		56+00.00	19	19
URBAN	SB	52+64.80		50+49.30	5	5
URBAN	NB	71+00.00		56+00.00	19	19
URBAN	NB	49+08.90		47+00.00	5	5
URBAN	SB	56+00.00		43+00.00	16	16
URBAN	SB	56+00.00		45+00.00	14	14
SUB-TOTAL FAP 676:					522	522
RURAL TOTAL:					495	495
URBAN TOTAL:					430	430
TOTAL FAS 2466 & FAP 676:					925	925
USE TOTAL:					925	925

MODEL: S:\MODEL\MH\MS...
 FILE: \\mhc...
 PROJECT: 201003\DOT\Documents\DOT...
 FILE: \\mhc...

USER NAME = monjardinnr	DESIGNED -	REVISED -
	DRAWN -	REVISED -
PLOT SCALE = 40,0219' / in.	CHECKED -	REVISED -
PLOT DATE = 3/10/2022	DATE -	REVISED -

**STATE OF ILLINOIS
DEPARTMENT OF TRANSPORTATION**

SCHEDULES OF QUANTITIES

SCALE: NONE SHEET 6 OF 7 SHEETS STA. TO STA.

F.A. RTE.	SECTION	COUNTY	TOTAL SHEETS	SHEET NO.
*	(9,10,11)RS-4,(9-1,9)RS-1	MCLEAN	45	21
*FAS 2466 & FAP 676 (US 150)			CONTRACT NO. 70E03	
ILLINOIS		FED. AID PROJECT		

SEC. 29, T. 24N., R. 1W., 3RD P.M.

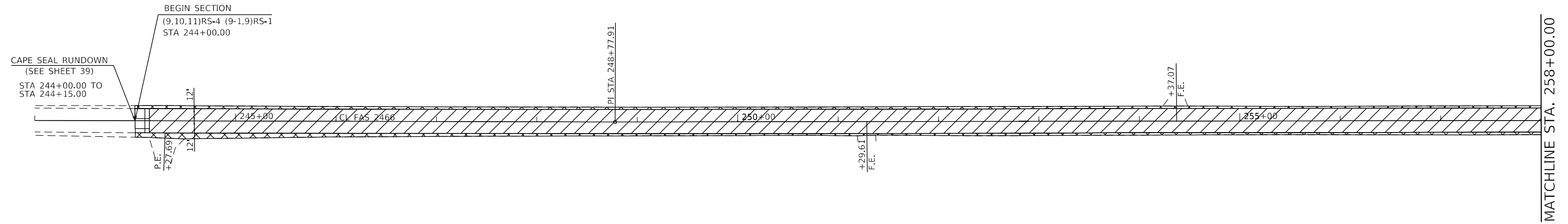

- CAPE SEAL
- AGGREGATE WEDGE SHOULDER, TYPE B
- CAPE SEAL RUNDOWN

SEC. 30, T. 24N., R. 1W., 3RD P.M.

SEC. 32, T. 24N., R. 1W., 3RD P.M.

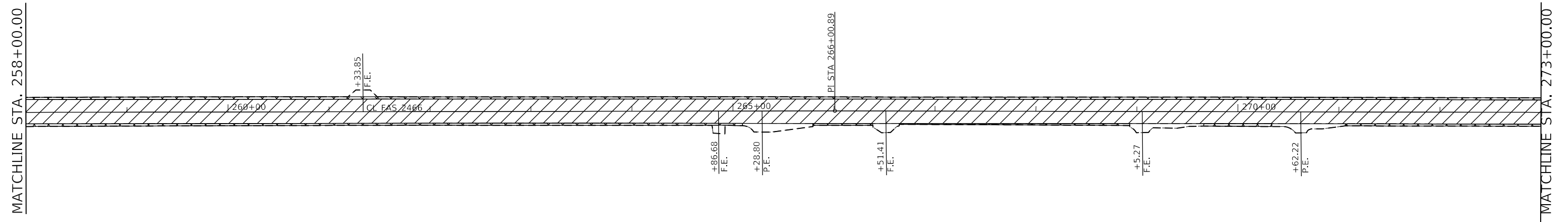

- CAPE SEAL
- AGGREGATE WEDGE SHOULDER, TYPE B

SEC. 31, T. 24N., R. 1W., 3RD P.M.

MODEL: Default
 FILE: MainE: p:\bldg-civ-bentley.com\PHWDOT\Documents\DOT Offices\Bentley: S:\Projects\0570603\CADD\DATA\CAD\Drawings\0570603-rt-elb-worth.dgn

USER NAME = keysmj	DESIGNED -	REVISED -
DRAWN -	REVISOR -	
PLOT SCALE = 100.0000' / in.	CHECKED -	REVISOR -
PLOT DATE = 1/26/2022	DATE -	REVISOR -

**STATE OF ILLINOIS
DEPARTMENT OF TRANSPORTATION**



PLAN SHEET

SCALE: 1" = 50' SHEET 1 OF 10 SHEETS STA. 243+00.00 TO STA. 273+00.00

F.A.S. RTE.	SECTION	COUNTY	TOTAL SHEETS	SHEET NO.
2466	*	MCLEAN	45	23
*(9,10,11)RS-4,(9-1,9)RS-1		CONTRACT NO. 70E03		
ILLINOIS		FED. AID PROJECT		

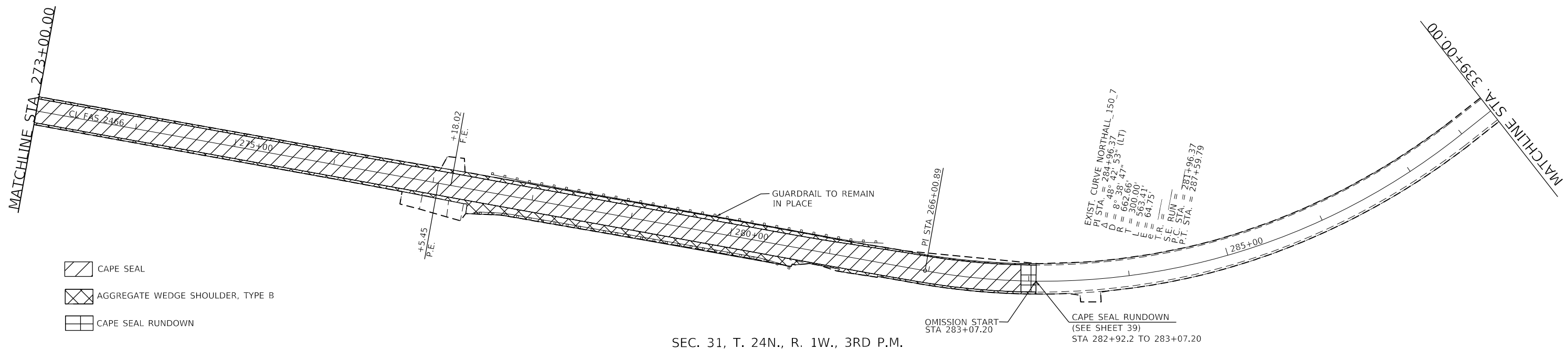
SEC. 32, T. 24N., R. 1W., 3RD P.M.



-  CAPE SEAL
-  AGGREGATE WEDGE SHOULDER, TYPE B
-  CAPE SEAL RUNDOWN

SEC. 31, T. 24N., R. 1W., 3RD P.M.

CARLOCK OMISSION:
STATION 283+07.20 TO STATION 339+08.08

MODEL: Default
 FILE: M:\MapE_Plan\11000000\11000000.dwg
 PROJECT: D:\Projects\11000000\11000000.dwg
 OFFICE: D:\Projects\11000000\11000000.dwg
 USER: keysmj

USER NAME = keysmj	DESIGNED -	REVISED -
PLOT SCALE = 100.0000' / in.	DRAWN -	REVISED -
PLOT DATE = 1/26/2022	CHECKED -	REVISED -
	DATE -	REVISED -

**STATE OF ILLINOIS
DEPARTMENT OF TRANSPORTATION**

PLAN SHEET

SCALE: 1" = 50' SHEET 2 OF 10 SHEETS STA. 243+00.00 TO STA. 273+00.00

F.A.S. RTE.	SECTION	COUNTY	TOTAL SHEETS	SHEET NO.
2466	*	MCLEAN	45	24
*(9,10,11)RS-4,(9-1,9)RS-1			CONTRACT NO. 70E03	
ILLINOIS FED. AID PROJECT				

SEC. 32, T. 24N., R. 1W., 3RD P.M.

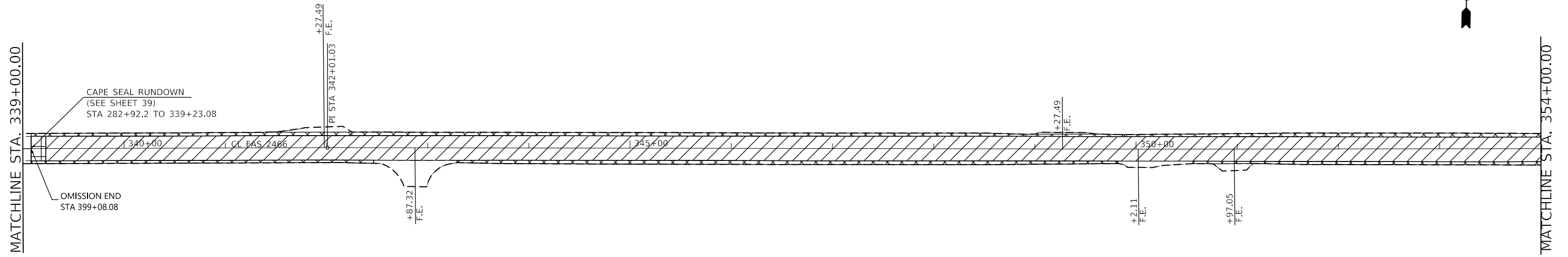

- CAPE SEAL
- AGGREGATE WEDGE SHOULDER, TYPE B
- CAPE SEAL RUNDOWN

SEC. 32, T. 24N., R. 1W., 3RD P.M.

SEC. 33, T. 24N., R. 1W., 3RD P.M.

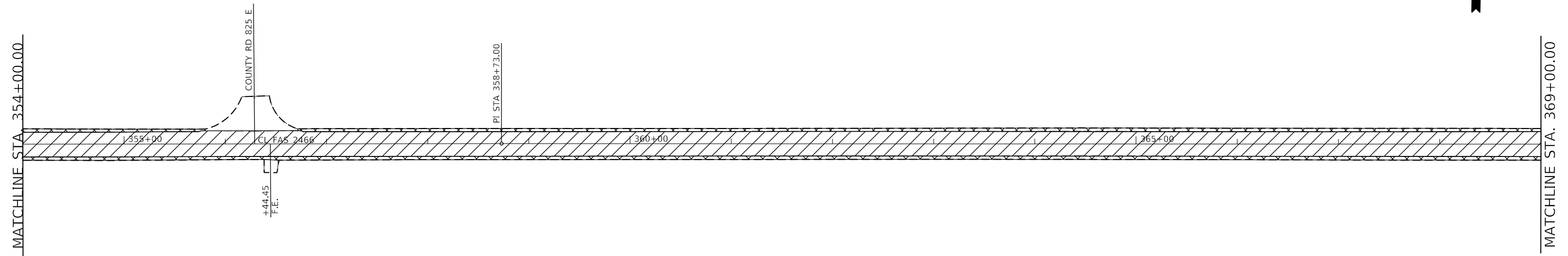

- CAPE SEAL
- AGGREGATE WEDGE SHOULDER, TYPE B

SEC. 33, T. 24N., R. 1W., 3RD P.M.

MODEL: Default
 FILE: MainE_PlanView.dwg
 PROJECT: S:\Projects\0570603\CADD\DATA\CAD\Drawings\0570603-eh-elb-wrth.dgn

USER NAME = keysmj	DESIGNED -	REVISED -
	DRAWN -	REVISED -
PLOT SCALE = 100,0000' / in.	CHECKED -	REVISED -
PLOT DATE = 1/26/2022	DATE -	REVISED -

**STATE OF ILLINOIS
DEPARTMENT OF TRANSPORTATION**

PLAN SHEET

SCALE: 1" = 50' SHEET 3 OF 10 SHEETS STA. 243+00.00 TO STA. 273+00.00

F.A.S. RTE.	SECTION	COUNTY	TOTAL SHEETS	SHEET NO.
2466	*	MCLEAN	45	25
*(9,10,11)RS-4,(9-1,9)RS-1		CONTRACT NO. 70E03		
ILLINOIS		FED. AID PROJECT		

SEC. 33, T. 24N., R. 1W., 3RD P.M.

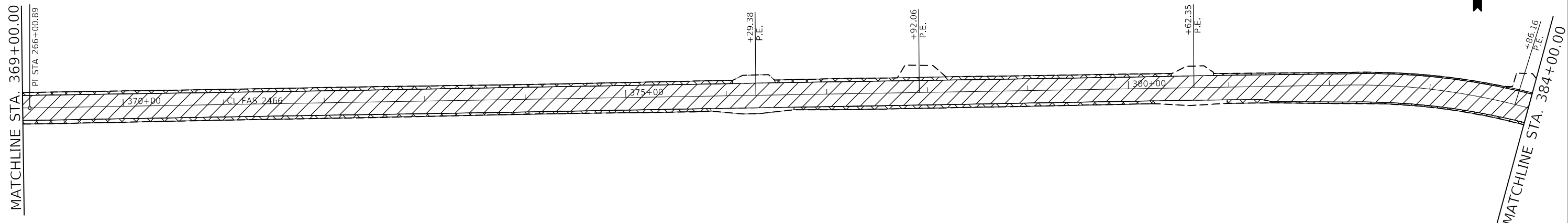

-  CAPE SEAL
-  AGGREGATE WEDGE SHOULDER, TYPE B

SEC. 33, T. 24N., R. 1W., 3RD P.M.

SEC. 33, T. 24N., R. 1W., 3RD P.M.

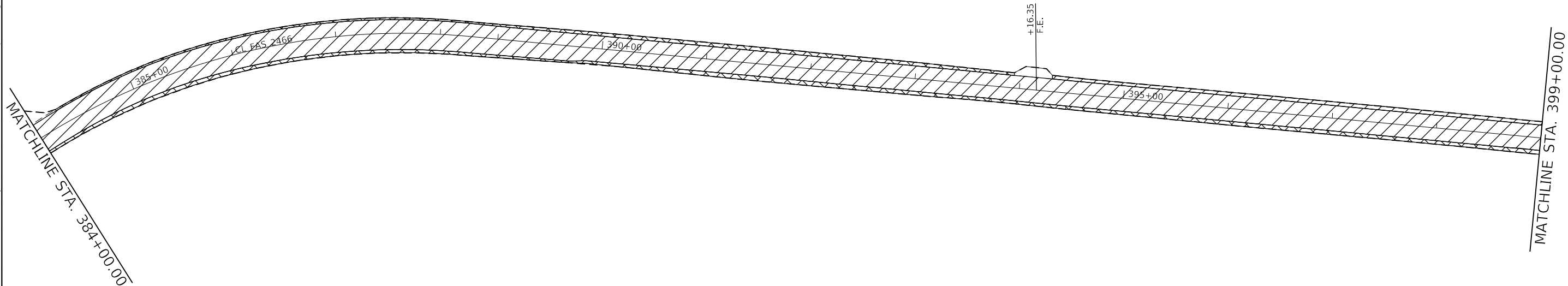
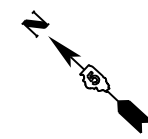

-  CAPE SEAL
-  AGGREGATE WEDGE SHOULDER, TYPE B

SEC. 33, T. 24N., R. 1W., 3RD P.M.

MOEFL - Default
FILE NAME: p:\projects\70E03\CADD\Drawings\DOT\Office\Drawings\Projects\70E03\Drawings\2466\2466-04.dwg

USER NAME = keysmj	DESIGNED -	REVISED -
	DRAWN -	REVISED -
PLOT SCALE = 100.0000' / in.	CHECKED -	REVISED -
PLOT DATE = 1/26/2022	DATE -	REVISED -

**STATE OF ILLINOIS
DEPARTMENT OF TRANSPORTATION**

PLAN SHEET

SCALE: 1" = 50' SHEET 4 OF 10 SHEETS STA. 243+00.00 TO STA. 273+00.00

F.A.S. RTE.	SECTION	COUNTY	TOTAL SHEETS	SHEET NO.
2466	*	MCLEAN	45	26
*(9,10,11)RS-4,(9-1,9)RS-1		CONTRACT NO. 70E03		
ILLINOIS		FED. AID PROJECT		

SEC. 34, T. 24N., R. 1W., 3RD P.M.

MATCHLINE STA. 399+00.00

MATCHLINE STA. 421+37.61

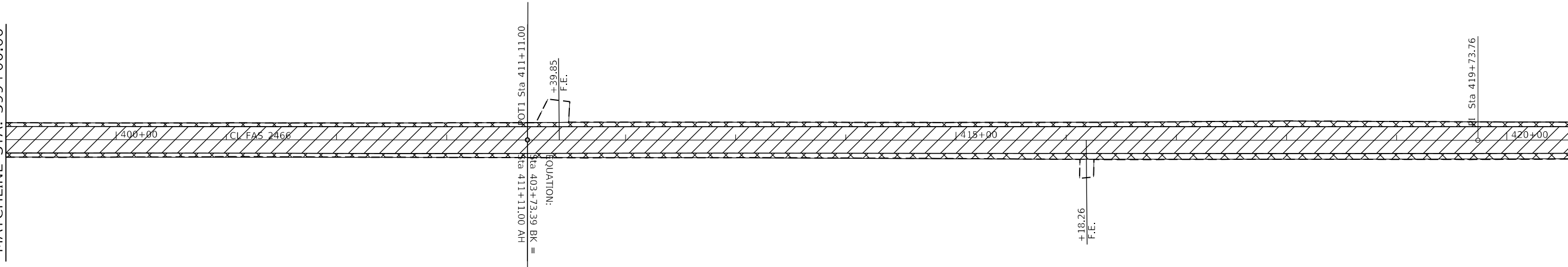
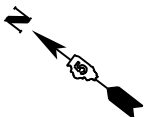

- CAPE SEAL
- AGGREGATE WEDGE SHOULDER, TYPE B

SEC. 34, T. 24N., R. 1W., 3RD P.M.

SEC. 34, T. 24N., R. 1W., 3RD P.M.

MATCHLINE STA. 421+37.61

MATCHLINE STA. 436+00.00

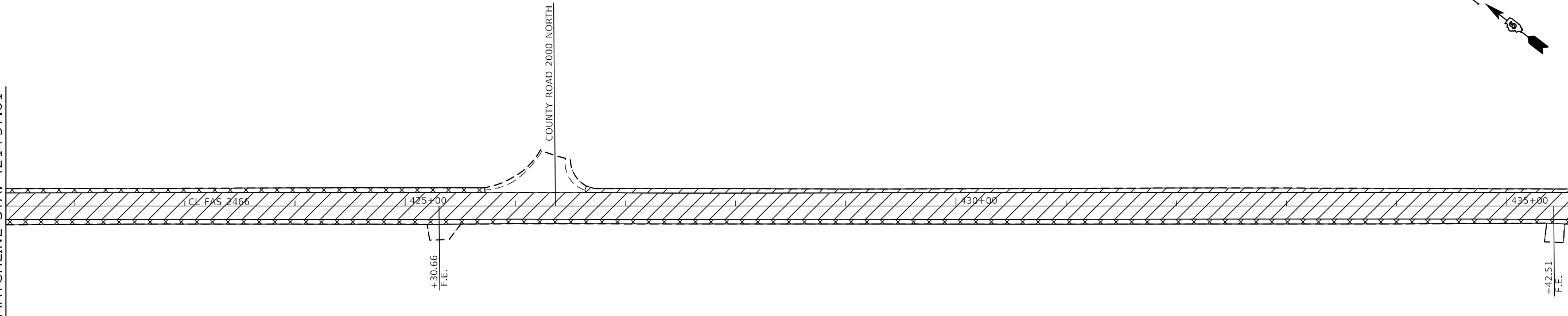
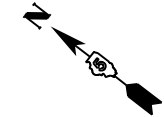

- CAPE SEAL
- AGGREGATE WEDGE SHOULDER, TYPE B

SEC. 34, T. 24N., R. 1W., 3RD P.M.

MODEL: Default
 FILE: MainE: p:\plottest-cw-behler\com-PRWIDOT\Documents\DOT Offices\Bhler, S\Projects\0570603\CADD\DATA\CAD\Revs\0570603-sh-elb-worth.dgn

USER NAME = keysmj	DESIGNED -	REVISED -
DRAWN -	REVISOR -	
PLOT SCALE = 100,0000' / in.	CHECKED -	REVISED -
PLOT DATE = 1/26/2022	DATE -	REVISED -

**STATE OF ILLINOIS
DEPARTMENT OF TRANSPORTATION**

PLAN SHEET

SCALE: 1" = 50' SHEET 5 OF 10 SHEETS STA. 243+00.00 TO STA. 273+00.00

F.A.S. RTE.	SECTION	COUNTY	TOTAL SHEETS	SHEET NO.
2466	*	MCLEAN	45	27
*(9,10,11)RS-4,(9-1,9)RS-1		CONTRACT NO. 70E03		
		ILLINOIS FED. AID PROJECT		

SEC. 3, T. 24N., R. 1W., 3RD P.M.

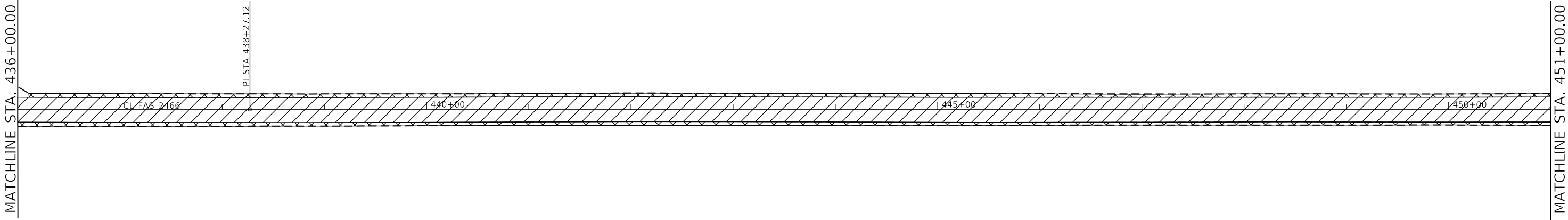
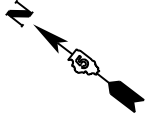

-  CAPE SEAL
-  AGGREGATE WEDGE SHOULDER, TYPE B

SEC. 3, T. 24N., R. 1W., 3RD P.M.

SEC. 3, T. 24N., R. 1W., 3RD P.M.

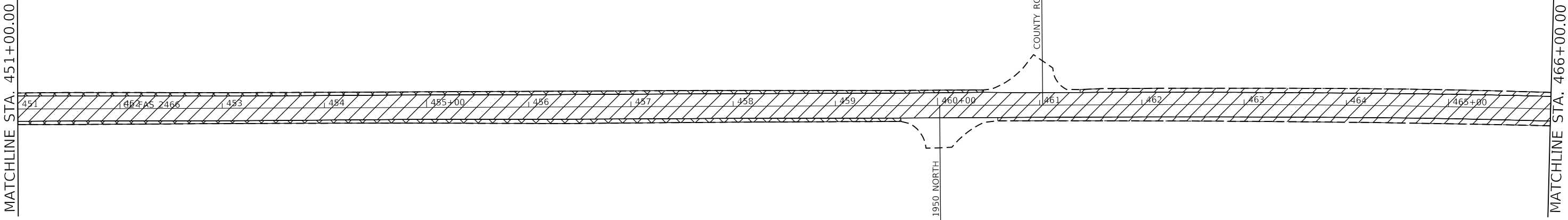
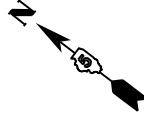

-  CAPE SEAL
-  AGGREGATE WEDGE SHOULDER, TYPE B

SEC. 3, T. 24N., R. 1W., 3RD P.M.

MODEL: Default
 FILE: M:\MSD_Plan\1000000000\1000000000\1000000000\1000000000\1000000000\1000000000\1000000000\1000000000\1000000000\1000000000.dgn

USER NAME = keysmj	DESIGNED -	REVISED -
	DRAWN -	REVISED -
PLOT SCALE = 100,0000 ' / in.	CHECKED -	REVISED -
PLOT DATE = 1/26/2022	DATE -	REVISED -

**STATE OF ILLINOIS
DEPARTMENT OF TRANSPORTATION**

PLAN SHEET			
SCALE: 1" = 50'	SHEET 6	OF 10 SHEETS	STA. 243+00.00 TO STA. 273+00.00

F.A.S. RTE.	SECTION	COUNTY	TOTAL SHEETS	SHEET NO.
2466	*	MCLEAN	45	28
*(9,10,11)RS-4,(9-1,9)RS-1			CONTRACT NO. 70E03	
ILLINOIS FED. AID PROJECT				

SEC. 3, T. 24N., R. 1W., 3RD P.M.

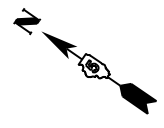

MATCHLINE STA. 466+00.00

MATCHLINE STA. 481+00.00

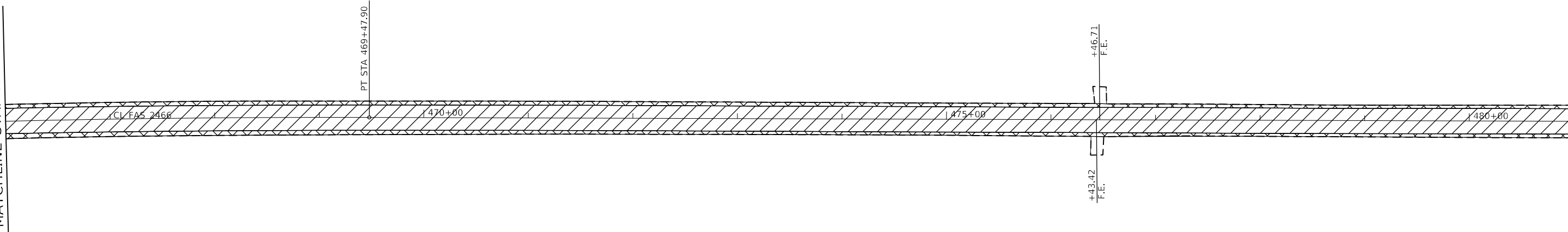

- CAPE SEAL
- AGGREGATE WEDGE SHOULDER, TYPE B

SEC. 3, T. 24N., R. 1W., 3RD P.M.

SEC. 3, T. 24N., R. 1W., 3RD P.M.

SEC. 10, T. 24N., R. 1W., 3RD P.M.

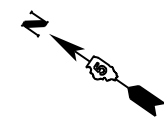

MATCHLINE STA. 481+00.00

MATCHLINE STA. 496+00.00

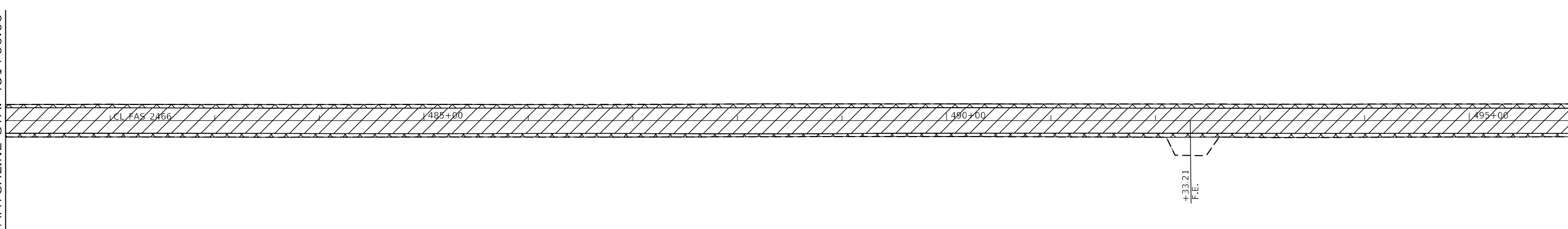

- CAPE SEAL
- AGGREGATE WEDGE SHOULDER, TYPE B

SEC. 3, T. 24N., R. 1W., 3RD P.M.

SEC. 10, T. 24N., R. 1W., 3RD P.M.

MODEL: Default
 FILE: MainE_Plan\Roadway\Drawings\DOT\Office\Drawings\Projects\0570603\CADD\Drawings\0570603-rt-ebn-wrth.dgn

USER NAME = keysmj	DESIGNED -	REVISED -
	DRAWN -	REVISED -
PLOT SCALE = 100.0000' / in.	CHECKED -	REVISED -
PLOT DATE = 1/26/2022	DATE -	REVISED -

**STATE OF ILLINOIS
DEPARTMENT OF TRANSPORTATION**

PLAN SHEET

SCALE: 1" = 50' SHEET 7 OF 10 SHEETS STA. 243+00.00 TO STA. 273+00.00

F.A.S. RTE.	SECTION	COUNTY	TOTAL SHEETS	SHEET NO.
2466	*	MCLEAN	45	29
*(9,10,11)RS-4,(9-1,9)RS-1		CONTRACT NO. 70E03		
ILLINOIS FED. AID PROJECT				

SEC. 10, T. 24N., R. 1W., 3RD P.M.

SEC. 11, T. 24N., R. 1W., 3RD P.M.

MATCHLINE STA. 496+00.00

MATCHLINE STA. 511+00.00

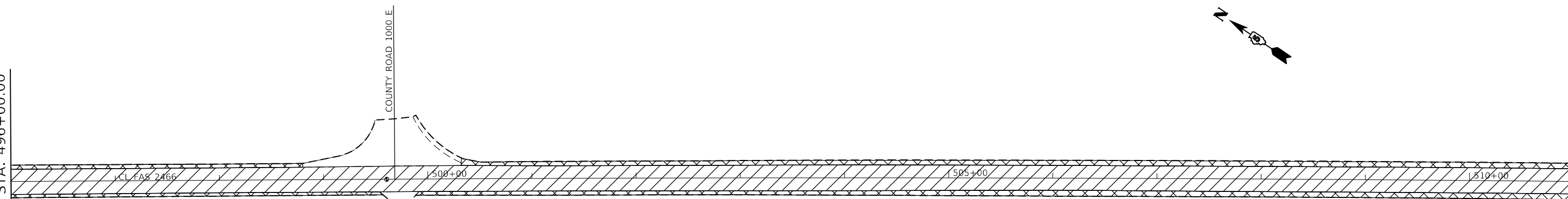

-  CAPE SEAL
-  AGGREGATE WEDGE SHOULDER, TYPE B

SEC. 10, T. 24N., R. 1W., 3RD P.M.

SEC. 11, T. 24N., R. 1W., 3RD P.M.

SEC. 11, T. 24N., R. 1W., 3RD P.M.

MATCHLINE STA. 511+00.00

MATCHLINE STA. 527+00.00

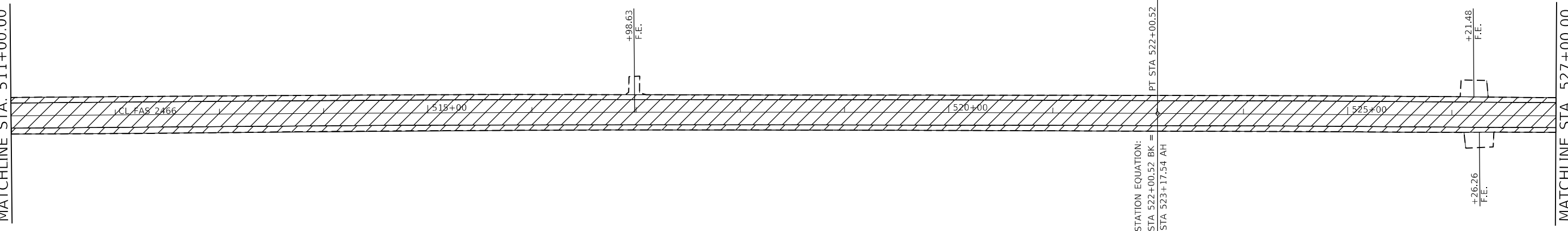

-  CAPE SEAL
-  AGGREGATE WEDGE SHOULDER, TYPE B

SEC. 11, T. 24N., R. 1W., 3RD P.M.

MODEL: Default
 FILE: MainE_PlanSheet.dwg
 PROJECT: S:\Projects\0570603\CADD\Drawings\0570603-eh-elb-worth.dgn

USER NAME = keysmj	DESIGNED -	REVISED -
PLOT SCALE = 100.0000' / in.	DRAWN -	REVISED -
PLOT DATE = 1/26/2022	CHECKED -	REVISED -
	DATE -	REVISED -

**STATE OF ILLINOIS
DEPARTMENT OF TRANSPORTATION**

PLAN SHEET
 SCALE: 1" = 50' SHEET 8 OF 10 SHEETS STA. 243+00.00 TO STA. 273+00.00

F.A.S. RTE.	SECTION	COUNTY	TOTAL SHEETS	SHEET NO.
2466	*	MCLEAN	45	30
*(9,10,11)RS-4,(9-1,9)RS-1		CONTRACT NO. 70E03		
		ILLINOIS FED. AID PROJECT		

SEC. 11, T. 24N., R. 1W., 3RD P.M.

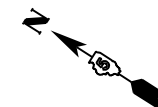

MATCHLINE STA. 527+00.00

MATCHLINE STA. 542+00.00

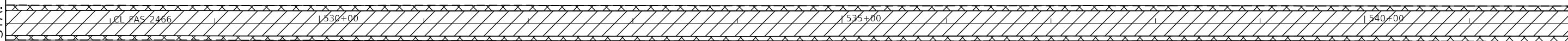

-  CAPE SEAL
-  AGGREGATE WEDGE SHOULDER, TYPE B

SEC. 11, T. 24N., R. 1W., 3RD P.M.

SEC. 11, T. 24N., R. 1W., 3RD P.M.

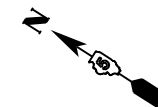

MATCHLINE STA. 542+00.00

MATCHLINE STA. 557+00.00

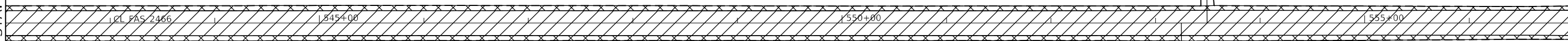

-  CAPE SEAL
-  AGGREGATE WEDGE SHOULDER, TYPE B

SEC. 11, T. 24N., R. 1W., 3RD P.M.

MODEL: Default
 FILE: MainE_PlanSheet.dwg
 PROJECT: S:\Projects\0570603\CADD\Drawings\0570603-rt-eh-eh-001.dwg

USER NAME = keysmj	DESIGNED -	REVISED -
	DRAWN -	REVISED -
PLOT SCALE = 100.0000' / in.	CHECKED -	REVISED -
PLOT DATE = 1/26/2022	DATE -	REVISED -

**STATE OF ILLINOIS
DEPARTMENT OF TRANSPORTATION**

PLAN SHEET

SCALE: 1" = 50' SHEET 9 OF 10 SHEETS STA. 243+00.00 TO STA. 273+00.00

F.A.S. RTE.	SECTION	COUNTY	TOTAL SHEETS	SHEET NO.
2466	*	MCLEAN	45	31
*(9,10,11)RS-4,(9-1,9)RS-1		CONTRACT NO. 70E03		
ILLINOIS		FED. AID PROJECT		

SEC. 11, T. 24N., R. 1W., 3RD P.M. SEC. 14, T. 24N., R. 1W., 3RD P.M.

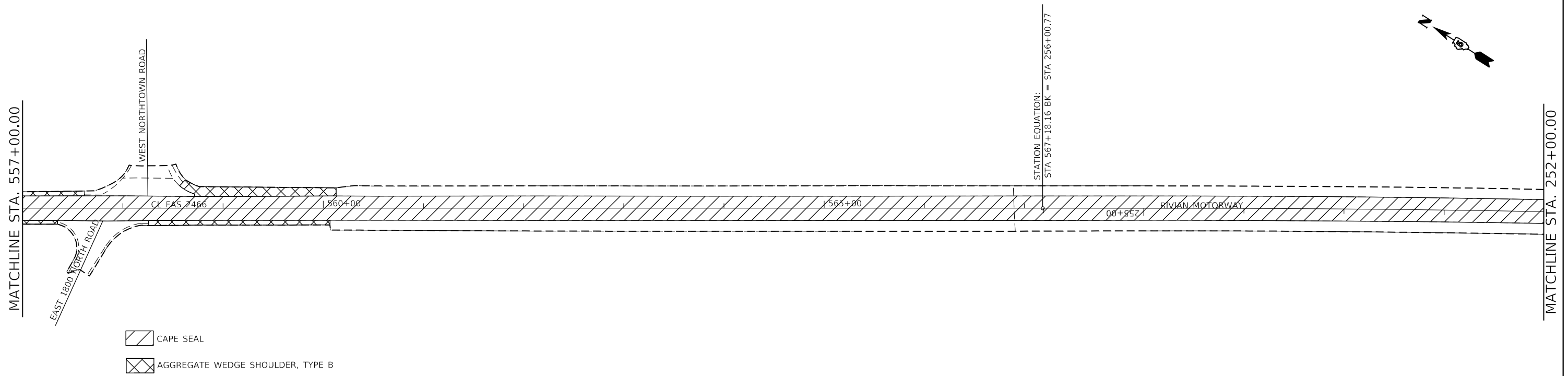

SEC. 11, T. 24N., R. 1W., 3RD P.M. SEC. 14, T. 24N., R. 1W., 3RD P.M.

MODEL: Default
 FILE: M:\MSR_Plan\11000000\11000000.dwg
 PROJECT: D:\Projects\11000000\11000000.dwg
 USER: keysmj

USER NAME = keysmj	DESIGNED -	REVISED -
	DRAWN -	REVISED -
PLOT SCALE = 100.0000' / in.	CHECKED -	REVISED -
PLOT DATE = 1/26/2022	DATE -	REVISED -

**STATE OF ILLINOIS
DEPARTMENT OF TRANSPORTATION**

PLAN SHEET

SCALE: 1" = 50' SHEET 10 OF 10 SHEETS STA. 243+00.00 TO STA. 273+00.00

F.A.S. RTE.	SECTION	COUNTY	TOTAL SHEETS	SHEET NO.
2466	*	MCLEAN	45	32
*(9,10,11)RS-4,(9-1,9)RS-1		CONTRACT NO. 70E03		
		ILLINOIS FED. AID PROJECT		

SEC. 14. T, 24N, 3RD P.M.

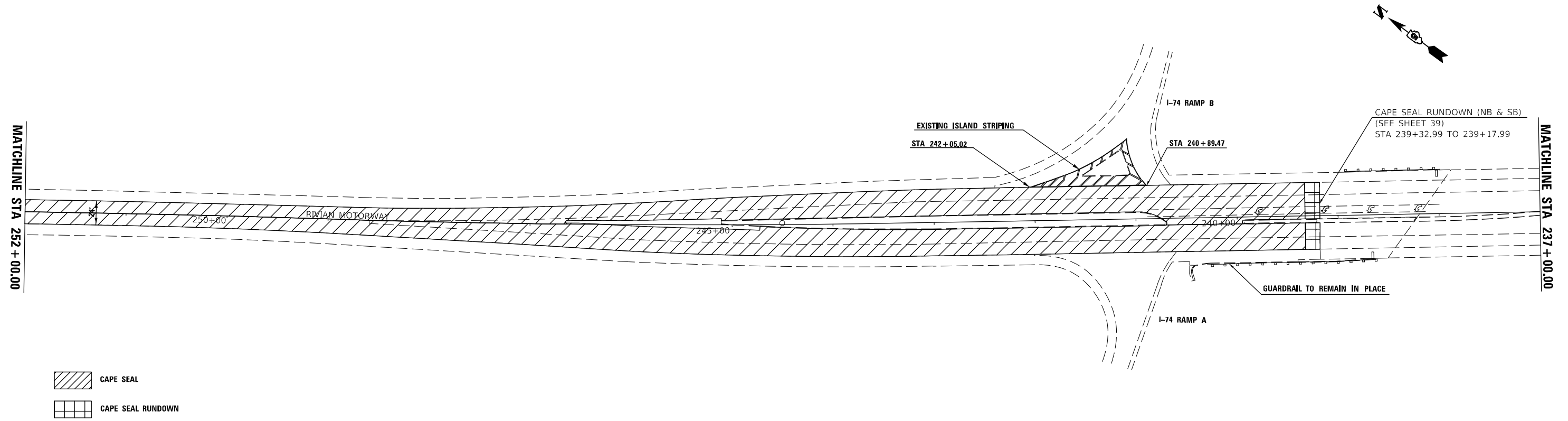

SEC. 13. T, 24N, 3RD P.M.

SEC. 13. T, 24N, 3RD P.M.

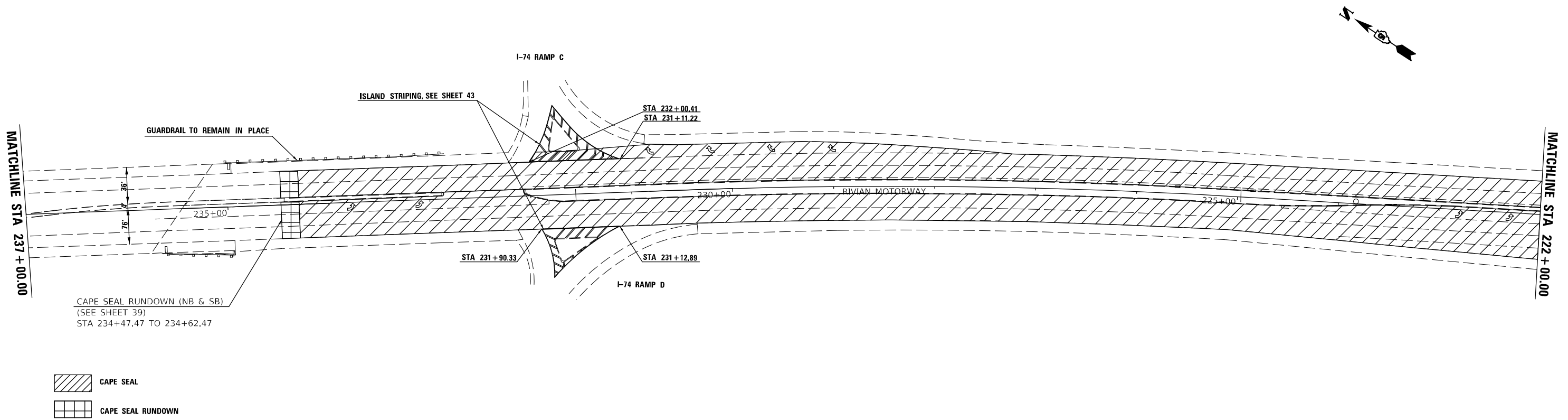

SEC. 14. T, 24N, 3RD P.M.

MODEL: SHODELNAME\$
FILE NAME: p:\illinois\seattleby.com\PIWDOT\Documents\DOT Offices\District 5\Projects\DS701935\CAD\Drawings\CAD\Drawings\DS701935-sh-4-11ens-south.dgn

USER NAME = monjardinrt	DESIGNED -	REVISED -
	DRAWN -	REVISED -
PLOT SCALE = 100.2822' / in.	CHECKED -	REVISED -
PLOT DATE = 1/27/2022	DATE -	REVISED -

STATE OF ILLINOIS
DEPARTMENT OF TRANSPORTATION

PLAN SHEET

SCALE: SHEET 1 OF 7 SHEETS STA. TO STA.

F.A.P. RTE. 676	SECTION *	COUNTY MCLEAN	TOTAL SHEETS 45	SHEET NO. 33
*19,10,11)RS-4,(9-1,9)RS-1		CONTRACT NO. 70E03		
ILLINOIS FED. AID PROJECT				

SEC. 13. T, 24N, 3RD P.M.

SEC. 24. T, 24N, 3RD P.M.

SEC. 24. T, 24N, 3RD P.M.

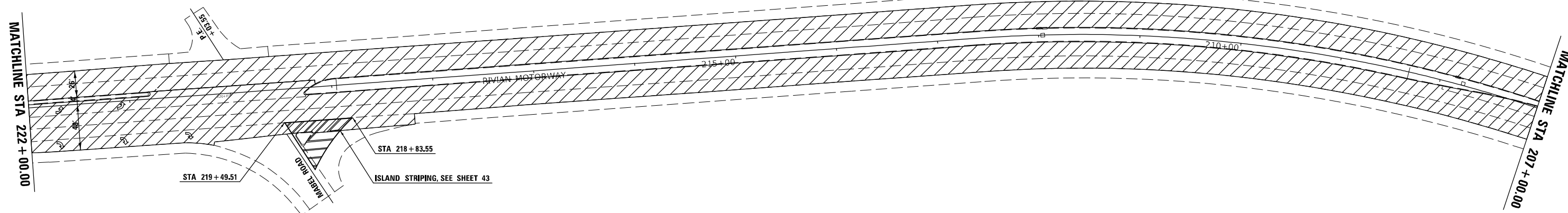
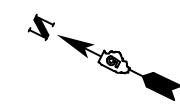

CAPE SEAL

SEC. 13. T, 24N, 3RD P.M.

SEC. 24. T, 24N, 3RD P.M.

SEC. 24. T, 24N, 3RD P.M.

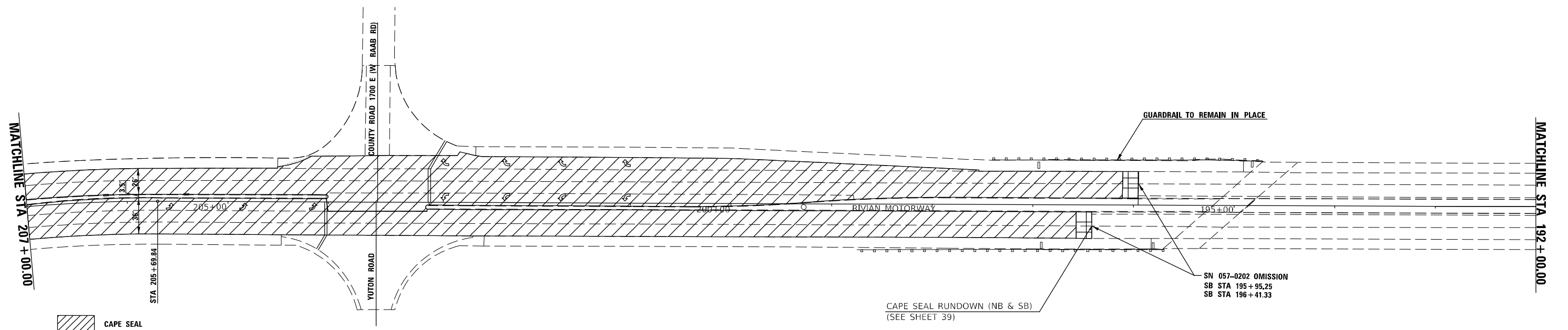
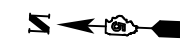

CAPE SEAL

CAPE SEAL RUNDOWN

SEC. 24. T, 24N, 3RD P.M.

MODEL: \$MODELNAMES
FILE NAME: pw:\illinois\pww_bentley.com\pww\dot\Documents\DOT_Offices\blair\et\3\projects\DS70E03\CAD\data\CAD\sheet\DS70E03\plan=outh.dgn

USER NAME = monjardint	DESIGNED -	REVISED -
DRAWN -	REVISED -	
PLOT SCALE = 100.2822' / in.	CHECKED -	REVISED -
PLOT DATE = 1/27/2022	DATE -	REVISED -

STATE OF ILLINOIS
DEPARTMENT OF TRANSPORTATION

PLAN SHEET
SCALE: SHEET 2 OF 7 SHEETS STA. TO STA.

F.A.P. RTE. 676	SECTION +	COUNTY MCLEAN	TOTAL SHEETS 45	SHEET NO. 34
(9,10,11)RS-4,(9-1,9)RS-1		CONTRACT NO. 70E03		
ILLINOIS FED. AID PROJECT				

SEC. 24. T, 24N, 3RD P.M.

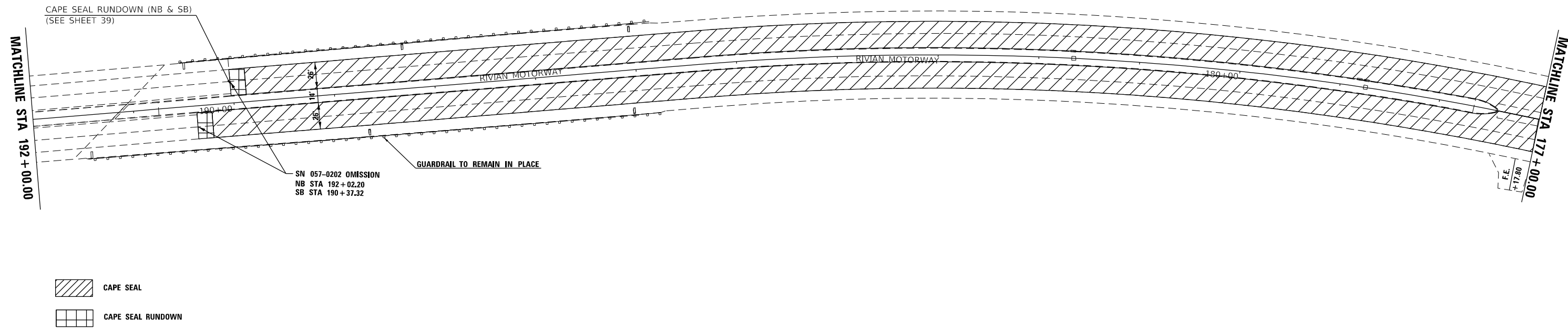

SEC. 24. T, 24N, 3RD P.M.

SEC. 24. T, 24N, 3RD P.M.

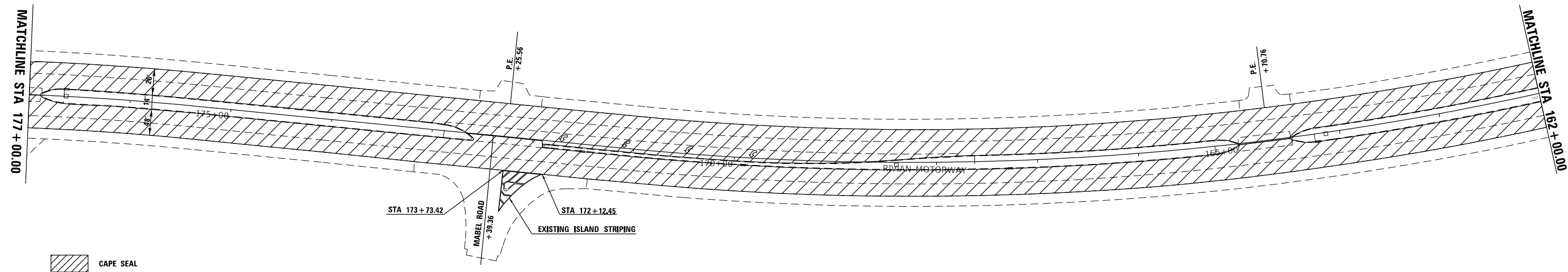

SEC. 23. T, 24N, 3RD P.M.

MODEL: Default
 FILE: Mabel_Plan.dwg
 PROJECT: S:\Projects\0570603\CADD\Drawings\0570603-24T-24N-3RD P.M.-Rivian.dwg

USER NAME = keysmj	DESIGNED -	REVISED -
PLOT SCALE = 100.0000' / in.	DRAWN -	REVISED -
PLOT DATE = 1/26/2022	CHECKED -	REVISED -
	DATE -	REVISED -

**STATE OF ILLINOIS
DEPARTMENT OF TRANSPORTATION**

PLAN SHEET

SCALE: SHEET 3 OF 7 SHEETS STA. TO STA.

F.A.P. RTE.	SECTION	COUNTY	TOTAL SHEETS	SHEET NO.
676	*	MCLEAN	45	35
*(9,10,11)RS-4,(9-1,9)RS-1		CONTRACT NO. 70E03		
ILLINOIS FED. AID PROJECT				

SEC. 25. T, 24N, 3RD P.M.

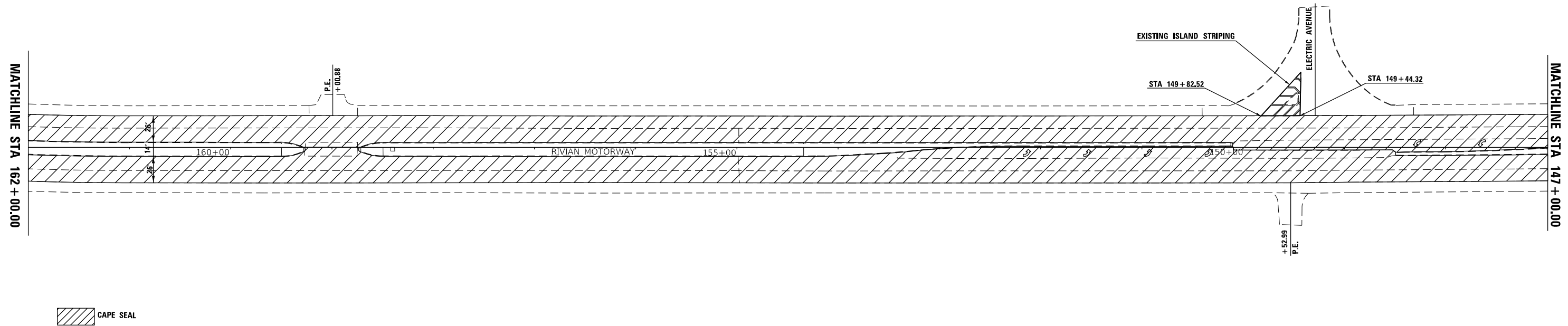

SEC. 26. T, 24N, 3RD P.M.

SEC. 25. T, 24N, 3RD P.M.

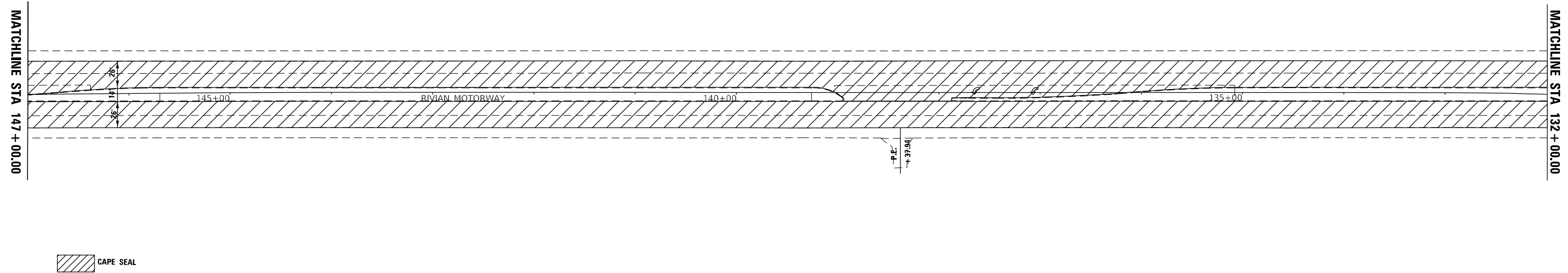

SEC. 26. T, 24N, 3RD P.M.

MODEL: Default
 FILE: MainE_Plan\Ildot-24x36\mif\com\PRWID\DOT\Documents\DOT Offices\Ildot\Ildot\Projects\70E03\CADD\Drawings\70E03-4-11-24\plan-south.dgn

USER NAME = keysmj	DESIGNED -	REVISED -
	DRAWN -	REVISED -
PLOT SCALE = 100,0000' / in.	CHECKED -	REVISED -
PLOT DATE = 1/26/2022	DATE -	REVISED -

**STATE OF ILLINOIS
DEPARTMENT OF TRANSPORTATION**

PLAN SHEET

SCALE: SHEET 4 OF 7 SHEETS STA. TO STA.

F.A.P. RTE.	SECTION	COUNTY	TOTAL SHEETS	SHEET NO.
676	*	MCLEAN	45	36
*(9,10,11)RS-4,(9-1,9)RS-1		CONTRACT NO. 70E03		
ILLINOIS		FED. AID PROJECT		

SEC. 25. T, 24N, 3RD P.M.

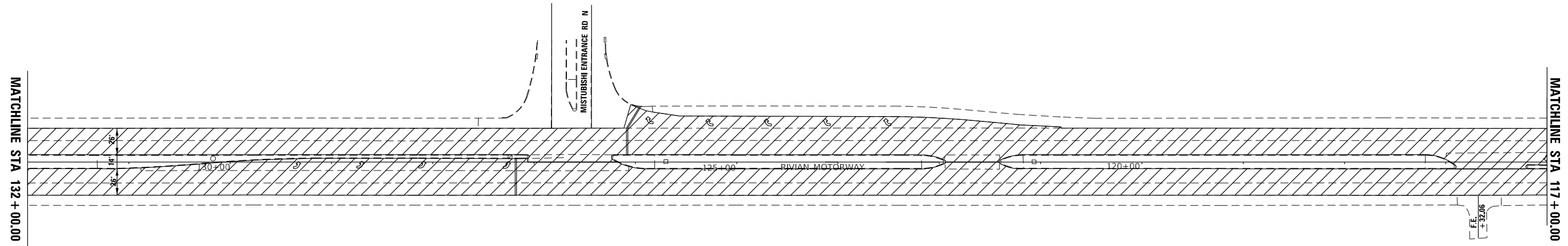

MATCHLINE STA 132 + 00.00

MATCHLINE STA 117 + 00.00

CAPE SEAL

SEC. 26. T, 24N, 3RD P.M.

SEC. 25. T, 24N, 3RD P.M.

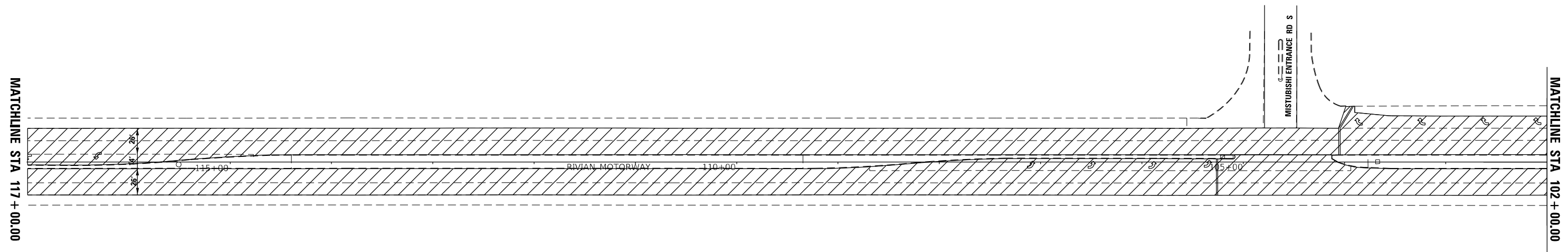

MATCHLINE STA 117 + 00.00

MATCHLINE STA 102 + 00.00

CAPE SEAL

SEC. 26. T, 24N, 3RD P.M.

MODEL: Default
 FILE: MainE_PlanSheet.dwg
 PROJECT: S:\Projects\70E03\CADD\AutoCAD\Drawings\70E03-PlanSheet.dwg

USER NAME = keysmj	DESIGNED -	REVISED -
	DRAWN -	REVISED -
PLOT SCALE = 100.0000' / in.	CHECKED -	REVISED -
PLOT DATE = 1/26/2022	DATE -	REVISED -

**STATE OF ILLINOIS
DEPARTMENT OF TRANSPORTATION**

PLAN SHEET

SCALE: SHEET 5 OF 7 SHEETS STA. TO STA.

F.A.P. RTE.	SECTION	COUNTY	TOTAL SHEETS	SHEET NO.
676	*	MCLEAN	45	37
*(9,10,11)RS-4,(9-1,9)RS-1		CONTRACT NO. 70E03		
ILLINOIS FED. AID PROJECT				

SEC. 35. T, 24N, 3RD P.M.

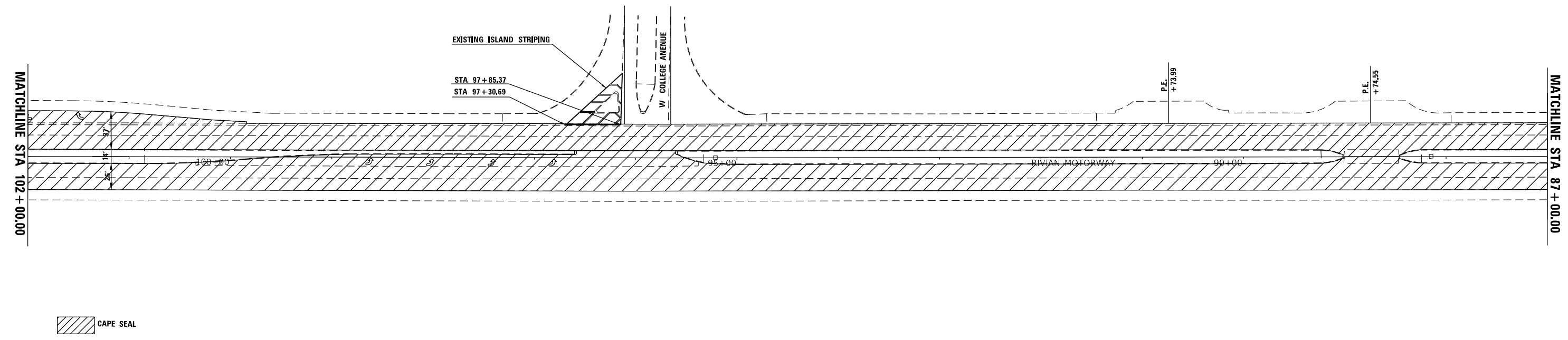

SEC. 36. T, 24N, 3RD P.M.

SEC. 35. T, 24N, 3RD P.M.

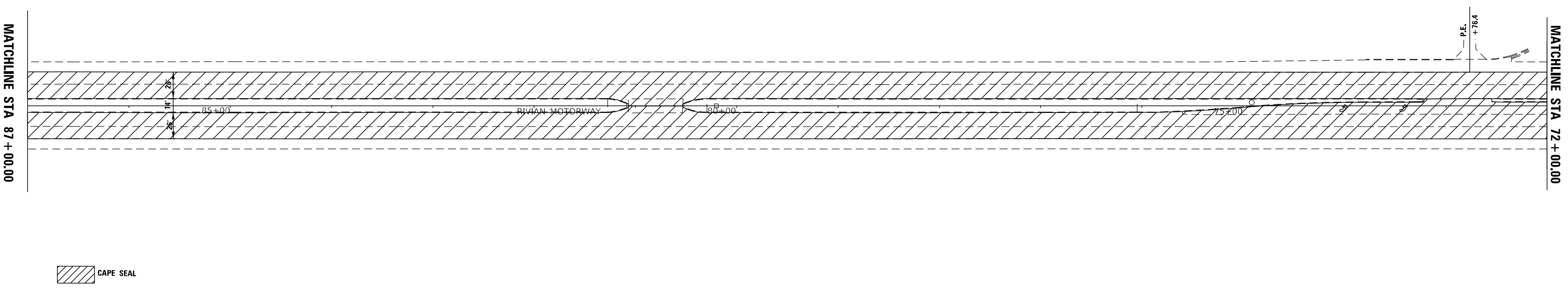

SEC. 36. T, 24N, 3RD P.M.

MODEL: Default
 FILE: MainE_Plan\Ildot-24\benlley.com\HWIDOT\Documents\DOT Offices\Bentley S:\Projects\0570E03\CADD\AutoCAD\Drawings\0570E03-24\plan-south.dgn

USER NAME = keysmj	DESIGNED -	REVISED -
PLOT SCALE = 100.0000' / in.	DRAWN -	REVISED -
PLOT DATE = 1/26/2022	CHECKED -	REVISED -
	DATE -	REVISED -

**STATE OF ILLINOIS
DEPARTMENT OF TRANSPORTATION**

PLAN SHEET			
SCALE:	SHEET 6	OF 7 SHEETS	STA. TO STA.

F.A.P. RTE. 676	SECTION *	COUNTY MCLEAN	TOTAL SHEETS 45	SHEET NO. 38
*(9.10.11)RS-4,(9-1.9)RS-1		CONTRACT NO. 70E03		
ILLINOIS FED. AID PROJECT				

SEC. 35. T, 24N, 3RD P.M.

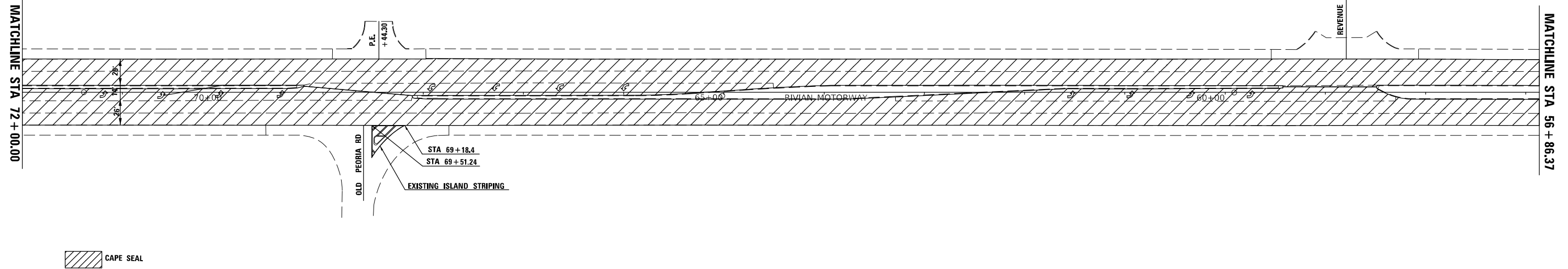
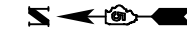

SEC. 36. T, 24N, 3RD P.M.

SEC. 35. T, 24N, 3RD P.M.

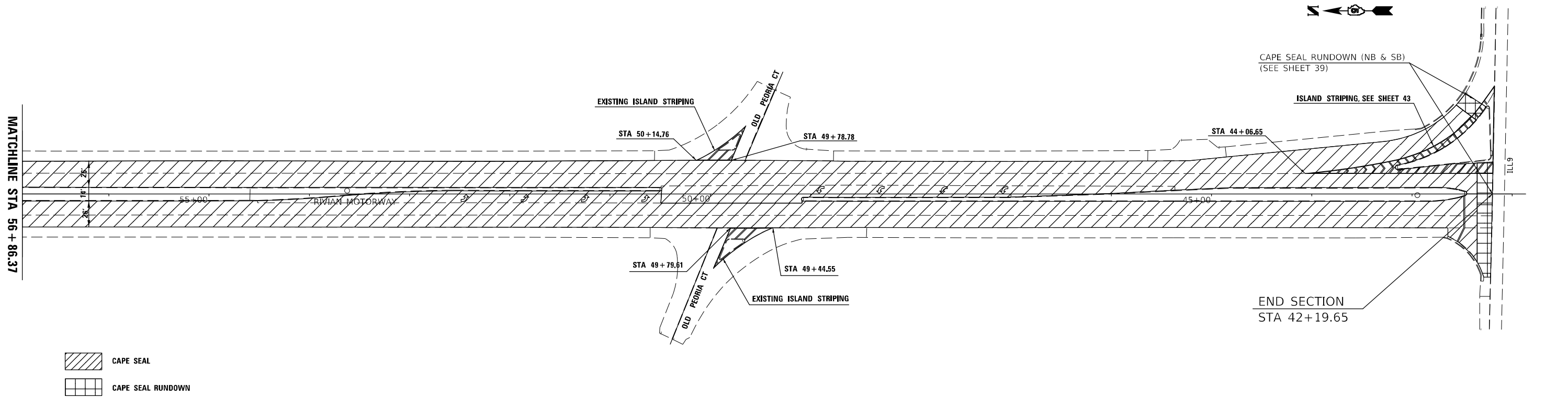
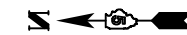

SEC. 36. T, 24N, 3RD P.M.

STATE OF ILLINOIS
DEPARTMENT OF TRANSPORTATION

PLAN SHEET

SCALE: SHEET 7 OF 7 SHEETS STA. TO STA.

F.A.P. RTE.	SECTION	COUNTY	TOTAL SHEETS	SHEET NO.
676	*	MCLEAN	45	39
*(9,10,11)RS-4,(9-1,9)RS-1		CONTRACT NO. 70E03		
ILLINOIS FED. AID PROJECT				

USER NAME = monjardinnrt	DESIGNED -	REVISED -
	DRAWN -	REVISED -
PLOT SCALE = 100.1820' / in.	CHECKED -	REVISED -
PLOT DATE = 1/27/2022	DATE -	REVISED -

MODEL: SHODLNAME\$ FILE: NAME: I:\MIS\GIS\Bentley\com:PWIDOT\Documents\DOT Offices\Dist\et_S\Projects\DS70E03\CADD\Drawn\CD\Drawn\DS70E03-shil-lanesa.dgn

CAPE SEAL RUNDOWN DETAIL

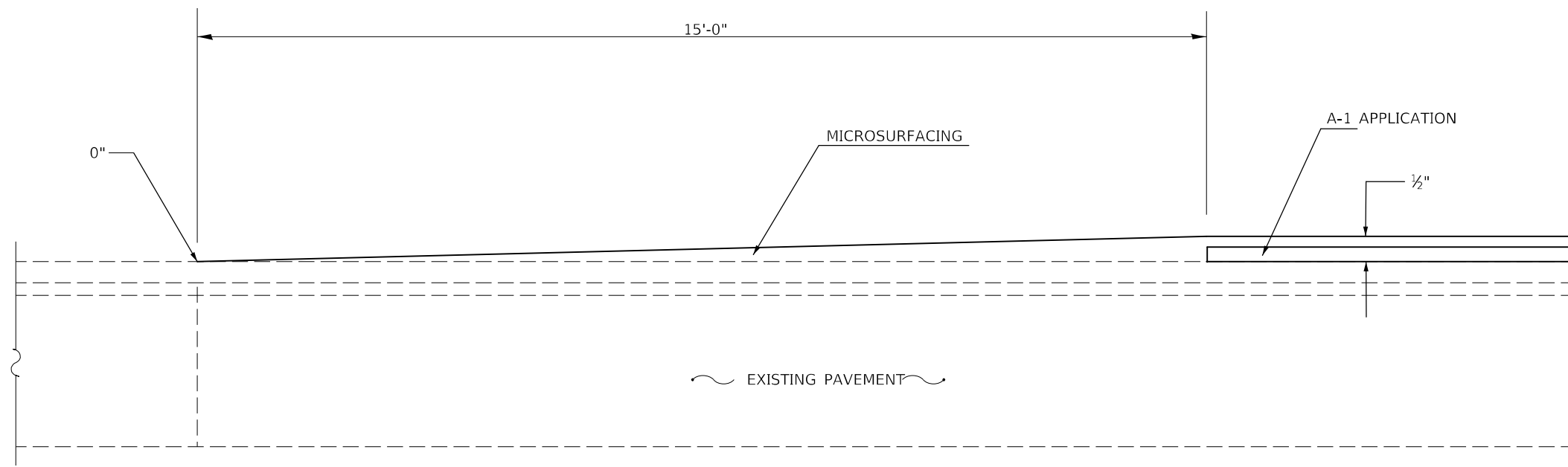

NOTE:
 THE INTENT OF THIS DETAIL IS TO SHOW THE METHOD OF APPLICATION
 FOR CAPE SEAL OVERLAY AT THE BEGINNING AND ENDING STATIONS AND
 STRUCTURE OMISSIONS THROUGHOUT THE JOB.

MODEL: \$MODELNAME\$
 FILE NAME: p:\illinois-pw\jenl\by.com\PIV\DOT\Documents\DOT_Offices\Detailer_S\Projects\0570103\CAPE Seal\CAD\Sheet\0570103-s1-Details.dgn

USER NAME = monjardinrt	DESIGNED -	REVISED -
	DRAWN -	REVISED -
PLOT SCALE = 40.1207' / in.	CHECKED -	REVISED -
PLOT DATE = 1/27/2022	DATE -	REVISED -

**STATE OF ILLINOIS
 DEPARTMENT OF TRANSPORTATION**

CAPE SEAL RUNDOWN DETAIL

SCALE: NONE SHEET 1 OF 1 SHEETS STA. TO STA.

F.A. RTE.	SECTION	COUNTY	TOTAL SHEETS	SHEET NO.
9	(9,10,11)RS-4,(9-1,9)RS-1	MCCLEAN	45	40
FAS 2466 & FAP 676		CONTRACT NO. 70E03		
ILLINOIS FED. AID PROJECT				

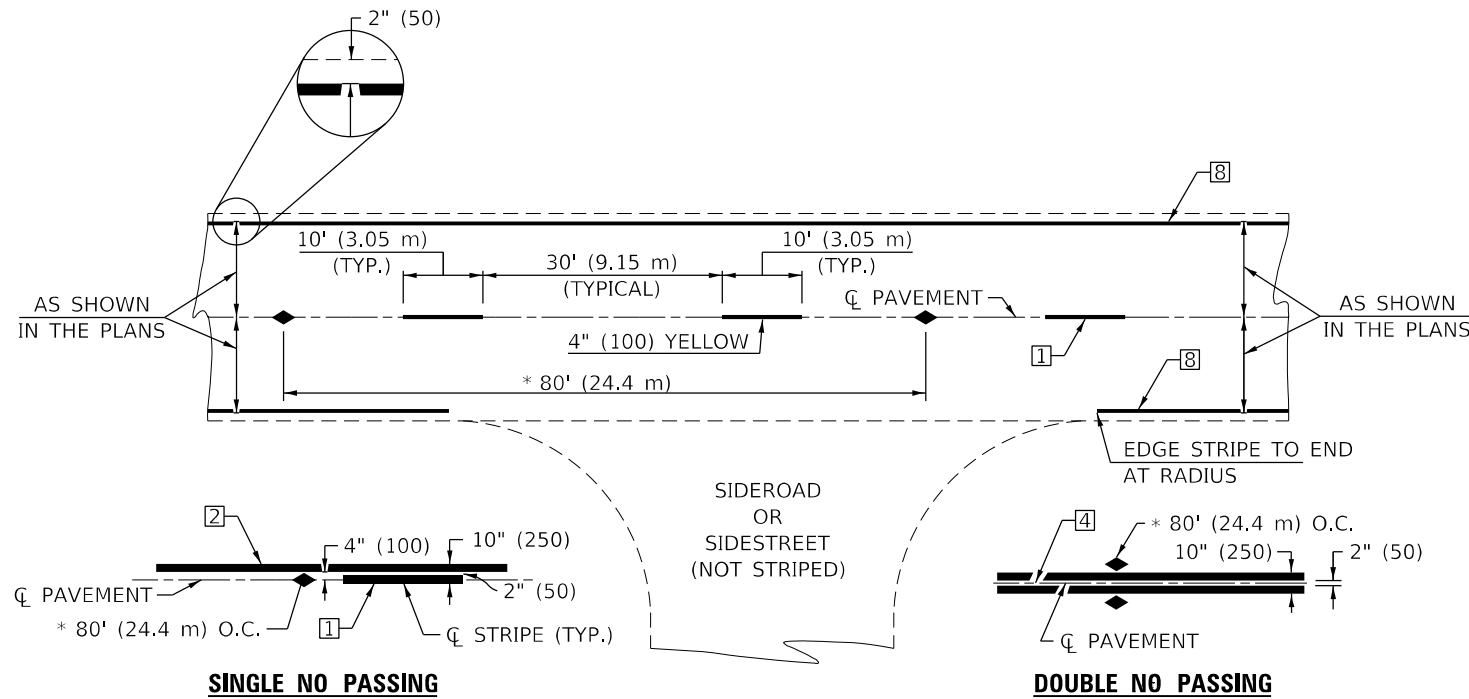

* REDUCE TO 40' (12.2 m) O.C. ON CURVES WITH POSTED OR ADVISORY SPEEDS OF 45 mph (70 km/h) OR LESS.

TWO LANE/TWO WAY

TYPICAL PAVEMENT MARKING LEGEND

- 1 4" (100) SKIP-DASH (YELLOW)
- 2 4" (100) SOLID (YELLOW)
- 3 12" (300) DIAGONAL (YELLOW)
- 4 4" (100) DOUBLE YELLOW (NARROW)
- 5 RESERVED
- 6 RESERVED
- 7 4" (100) SKIP-DASH (WHITE)
- 8 4" (100) SOLID (WHITE)
- 9 12" (300) DIAGONAL (WHITE)
- 10 6" (150) SOLID (WHITE)
- 11 24" (600) STOP BAR (WHITE)
- 12 8" (200) SOLID (WHITE)
- 13 4" (100) LANE LINE EXTENSIONS (WHITE)
- 14 4" (100) PARKING WHITE

TYPICAL PAVEMENT MARKERS LEGEND

- ◆ TWO-WAY AMBER MARKER
- ▶ ONE-WAY AMBER MARKER
- ▷ ONE-WAY CRYSTAL MARKER

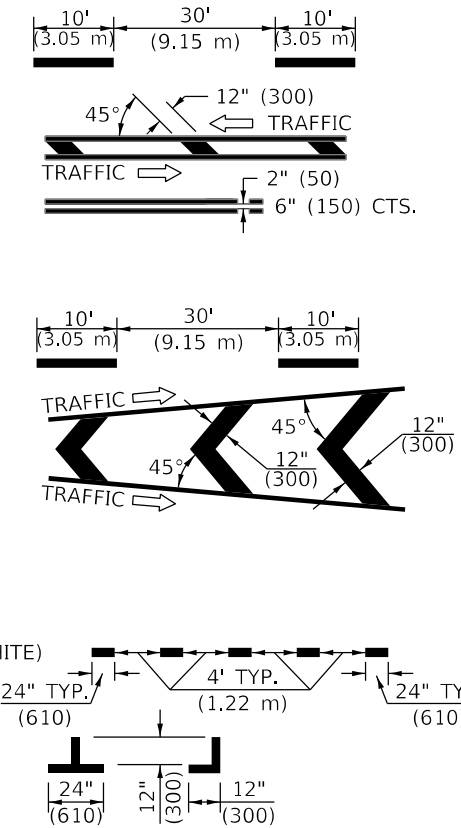

RURAL LEFT TURN

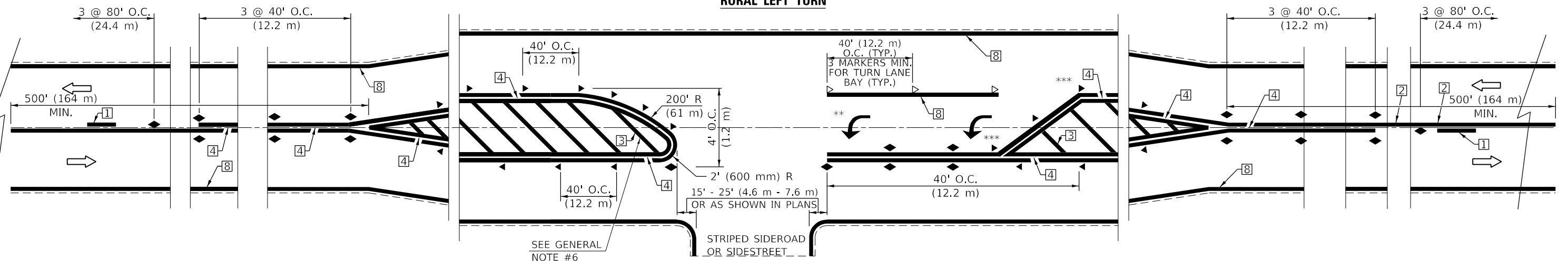

*** REDUCE SPACING IF NECESSARY TO ASSURE MARKERS AT CORNER POINTS.
 ** TURN ARROWS SHALL BE PLACED AS SHOWN ON SHEET #2.

Note: All dimensions are in INCHES (millimeters) unless otherwise shown.

STATE OF ILLINOIS
DEPARTMENT OF TRANSPORTATION

PAVEMENT MARKING AND MARKERS
(RURAL & URBAN APPLICATIONS)

DISTRICT 5 DETAIL NO. 7800AAAA

USER NAME = keysmj	DESIGNED -	REVISD - 11/06
	DRAWN -	REVISD - 9/2009 KJT
PLOT SCALE = 40.0000' / in.	CHECKED -	REVISD - 04/14 JLA
PLOT DATE = 1/26/2022	DATE -	REVISD - 3/2019 SWN

SCALE: NONE SHEET 1 OF 4 SHEETS STA. TO STA.

F.A. RTE.	SECTION	COUNTY	TOTAL SHEETS	SHEET NO.
*	(9,10,11)RS-4,(9-1,9)RS-1	MCLEAN	45	41
FAS 2466 & FAP 676		CONTRACT NO. 70E03		
ILLINOIS FED. AID PROJECT				

MODEL: Default
 FILE: MainE:proj\pblib-civ-bentley.com\PHWDOT\Documents\DOT Offices\Detail: S:\Projects\0570E03\CADD\Drawings\0570E03-sh-Detail.dgn

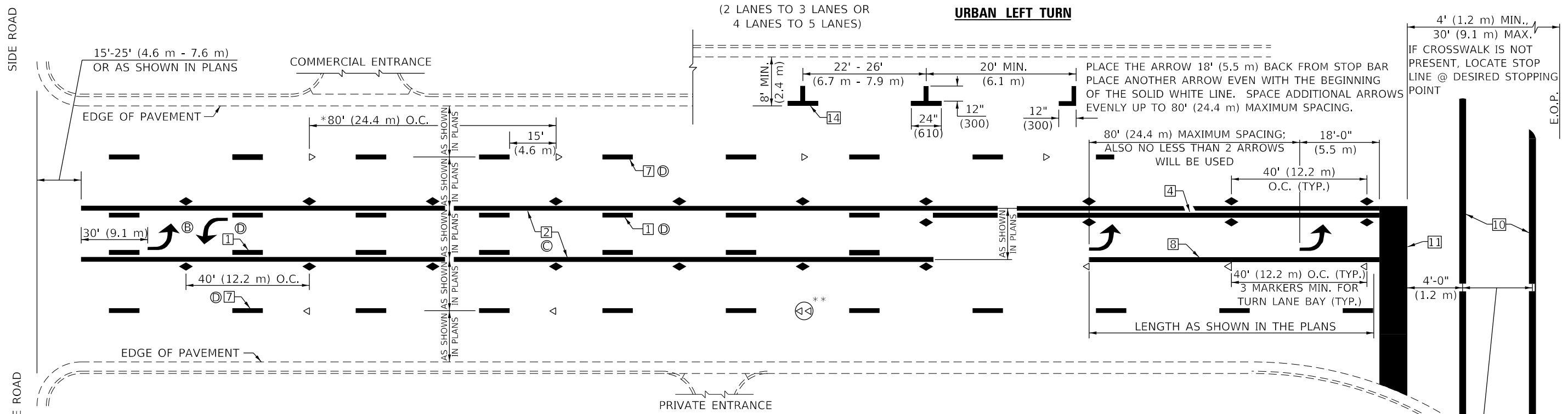

* REDUCE TO 40 FEET (12.2 METERS) ON CENTER ON CURVES WHERE ADVISORY SPEEDS ARE 10 MPH (15 km/h) LOWER THAN POSTED SPEEDS.

** DOUBLE LANE LINE MARKERS SHALL BE SPECIFIED AND SPACED AS SHOWN IN HIGHWAY STANDARD 781001 FOR MULTI-LANE DIVIDED AND UNDIVIDED HIGHWAYS.

GENERAL NOTES:

- (B) TURN ARROW PAIRS SHALL BE PLACED AT 250' (75 m) INTERVALS AND SHALL BE EVENLY SPACED BETWEEN BOTH ENDS OF THE BIDIRECTIONAL LEFT TURN LANE.
- (C) THE SOLID YELLOW PAVEMENT MARKINGS [2] SHOULD GENERALLY START OR END NEAR THE RADIUS POINT OF EACH STREET RETURN EXCEPT WHERE ONE OR BOTH ENDS WOULD INCLUDE STOP BARS.
- (D) THE SKIP-DASH PAVEMENT MARKINGS [1] OR [7] SHOULD BE CENTERED BETWEEN BOTH ENDS OF EACH CITY BLOCK AND SHALL BE PLACED SO THEY LINE UP ACROSS FROM EACH OTHER. SEE EXAMPLE ON SHEET 2 OF 3.
- (E) USE LARGE ARROW SIZE FOR BOTH RURAL AND URBAN LOCATIONS. (SEE LAST PAGE OF SECTION 780x FOR SYMBOLS TABLE)

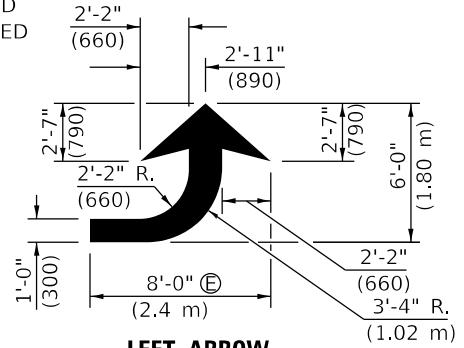

LEFT ARROW
REVERSE FOR RIGHT ARROW
AREA = 15.6 SQ. FT. (1.47 m²)
(WHITE)

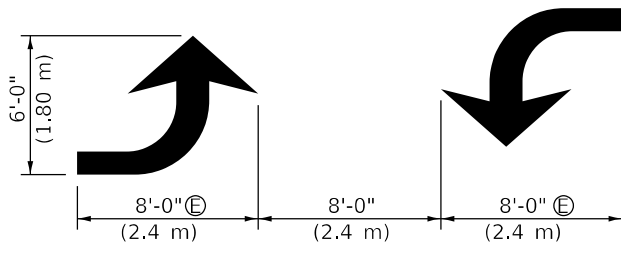

TYPICAL DOUBLE TURN ARROWS (WHITE)

BLOOMINGTON-NORMAL CITY LIMITS ONLY

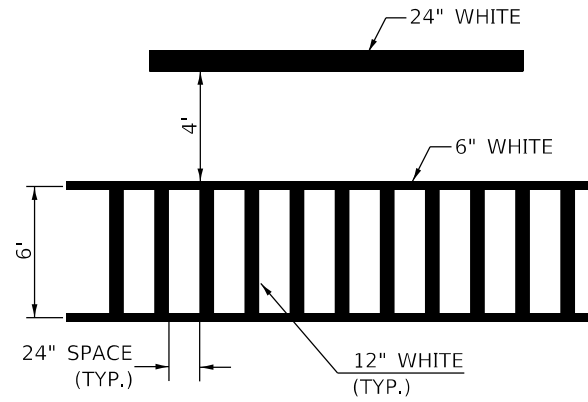

TYPICAL SPACING FOR CROSSWALKS & STOP BARS

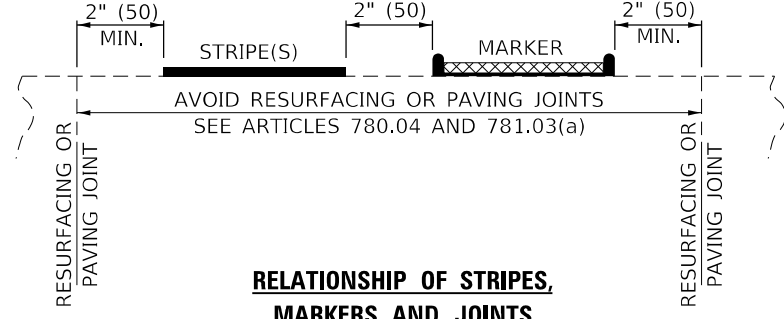

RELATIONSHIP OF STRIPES, MARKERS AND JOINTS

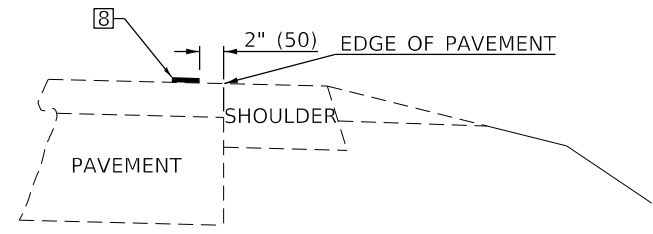

RELATIONSHIP OF EDGE LINE TO EDGE OF PAVEMENT
(SAFETY SHOULDER OR PAVED SURFACE)
SEE ARTICLE 780.04

Note: All dimensions are in INCHES (millimeters) unless otherwise shown.

MODEL: Default
 FILE NAME: p:\publib\civ\benlley.com\PHWD07\Documents\DOT Office\Drawings\Projects\0570E03\PH-Detail.dwg
 PROJECT: 0570E03\CADD\DATA\CAD\References\0570E03-Ph-Detail.dwg

USER NAME = keysmj	DESIGNED -	REVISED - 11/06
	DRAWN -	REVISED - 9/2009 KJT
PLOT SCALE = 40.0000 ' / in.	CHECKED -	REVISED - 04/14 JLA
PLOT DATE = 1/26/2022	DATE -	REVISED - 3/2019 SWN

**STATE OF ILLINOIS
DEPARTMENT OF TRANSPORTATION**

**PAVEMENT MARKING AND MARKERS
(RURAL & URBAN APPLICATIONS)**

SCALE: SHEET 2 OF 4 SHEETS STA. TO STA.

DISTRICT 5 DETAIL NO. 7800AAA				
F.A. RTE.	SECTION	COUNTY	TOTAL SHEETS	SHEET NO.
*	(9,10,11)RS-4,(9-1,9)RS-1	MCLEAN	45	42
FAS 2466 & FAP 676			CONTRACT NO. 70E03	
ILLINOIS		FED. AID PROJECT		

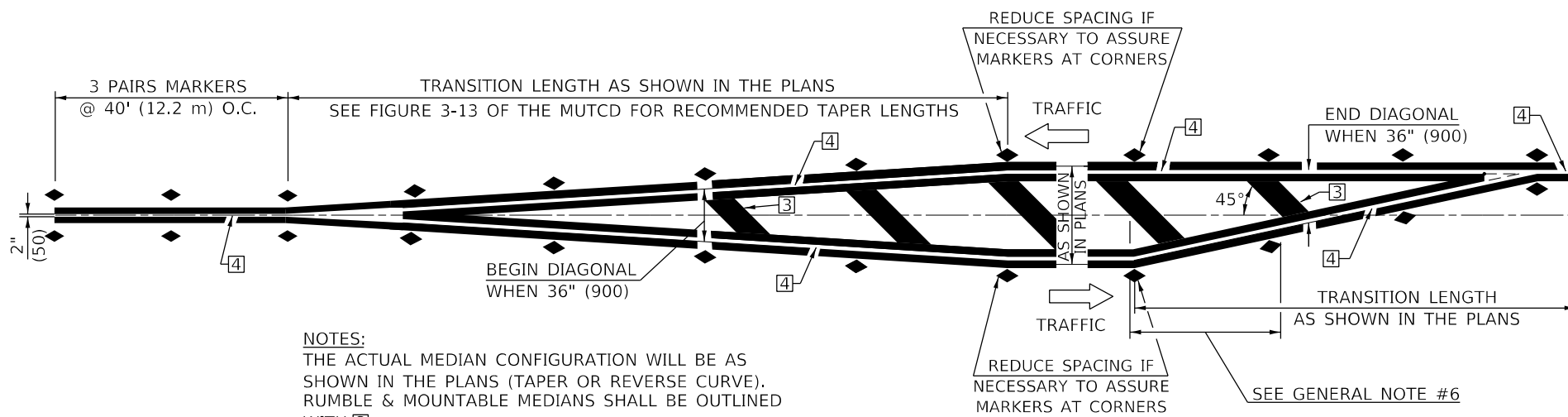

NOTES:
THE ACTUAL MEDIAN CONFIGURATION WILL BE AS SHOWN IN THE PLANS (TAPER OR REVERSE CURVE). RUMBLE & MOUNTABLE MEDIANS SHALL BE OUTLINED WITH [2].

TYPICAL MEDIAN TRANSITIONS

GENERAL NOTES

1. WHEN MEDIANS ARE PRESENT, PAVEMENT MARKINGS ARE TO BE PLACED ADJACENT TO MEDIANS.
2. SOME OF THE INFORMATION INCLUDED WITH THIS DETAIL MAY NOT BE APPLICABLE TO THIS IMPROVEMENT.
3. PAVEMENT MARKINGS ARE TO BE EXTENDED THROUGH OMISSIONS WHEN APPLICABLE.
4. A STRIPING KEY IS AVAILABLE ELSEWHERE AND SHALL BE SHOWN WHERE THE QUANTITIES ARE LISTED.
5. FINAL PAVEMENT MARKINGS SHALL BE IN PLACE PRIOR TO PLACING ANY RAISED REFLECTIVE PAVEMENT MARKERS.
6. THE FOLLOWING CRITERIA SHALL BE USED FOR SELECTING THE DIAGONAL PAVEMENT MARKING SPACING,
<30 MPH USE 15' (<50 km/h USE 4.5 m)
30-45 MPH USE 20' (50-75 km/h USE 6.0 m)
>45 MPH USE 30' (>75 km/h USE 9.0 m)

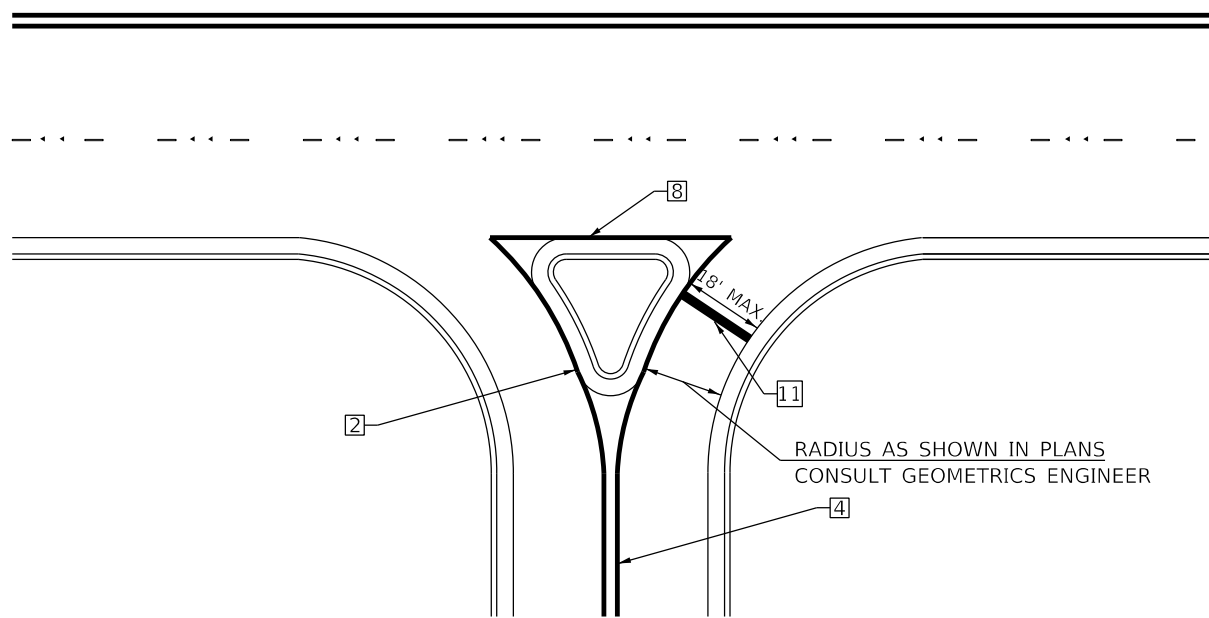

RIGHT IN - RIGHT OUT ACCESS

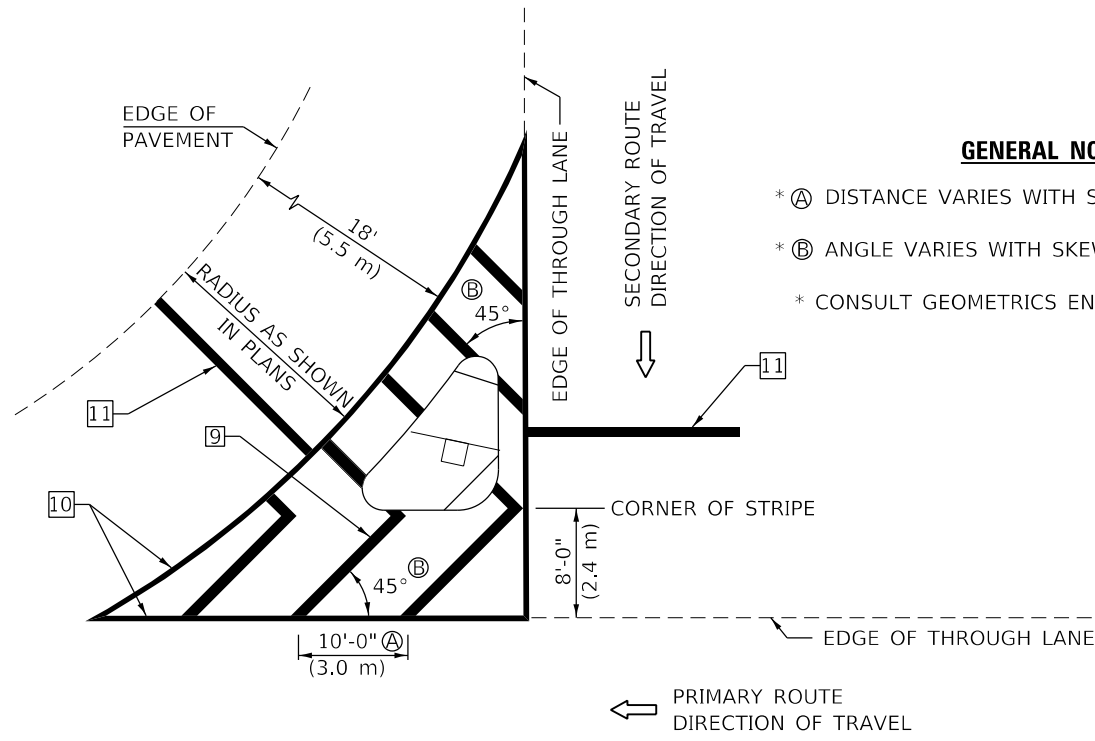

ISLAND

GENERAL NOTES

- * A DISTANCE VARIES WITH SKEW OF INTERSECTION.
- * B ANGLE VARIES WITH SKEW OF INTERSECTION.
- * CONSULT GEOMETRICS ENGINEER

Note: All dimensions are in INCHES (millimeters) unless otherwise shown.

MODEL: Default
 FILE: MainE_PlanDetail.dwg
 PROJECT: S:\Projects\2022\22-001\22-001.dwg
 PLOT DATE: 1/26/2022

USER NAME = keysmj	DESIGNED -	REVISD - 11/06
	DRAWN -	REVISD - 9/2009 KJT
PLOT SCALE = 40,0000 ' / in.	CHECKED -	REVISD - 04/14 JLA
PLOT DATE = 1/26/2022	DATE -	REVISD - 3/2019 SWN

**STATE OF ILLINOIS
DEPARTMENT OF TRANSPORTATION**

**PAVEMENT MARKING AND MARKERS
(RURAL & URBAN APPLICATIONS)**

SCALE: SHEET 3 OF 4 SHEETS STA. TO STA.

DISTRICT 5 DETAIL NO. 7800AAAA				
F.A. RTE.	SECTION	COUNTY	TOTAL SHEETS	SHEET NO.
*	(9,10,11)RS-4,(9-1,9)RS-1	MCLEAN	45	43
FAS 2466 & FAP 676			CONTRACT NO. 70E03	
ILLINOIS FED. AID PROJECT				

DESIGNER NOTE: SEE TABLE 2C-4 OF THE MUTCD FOR ADDITIONAL INFORMATION

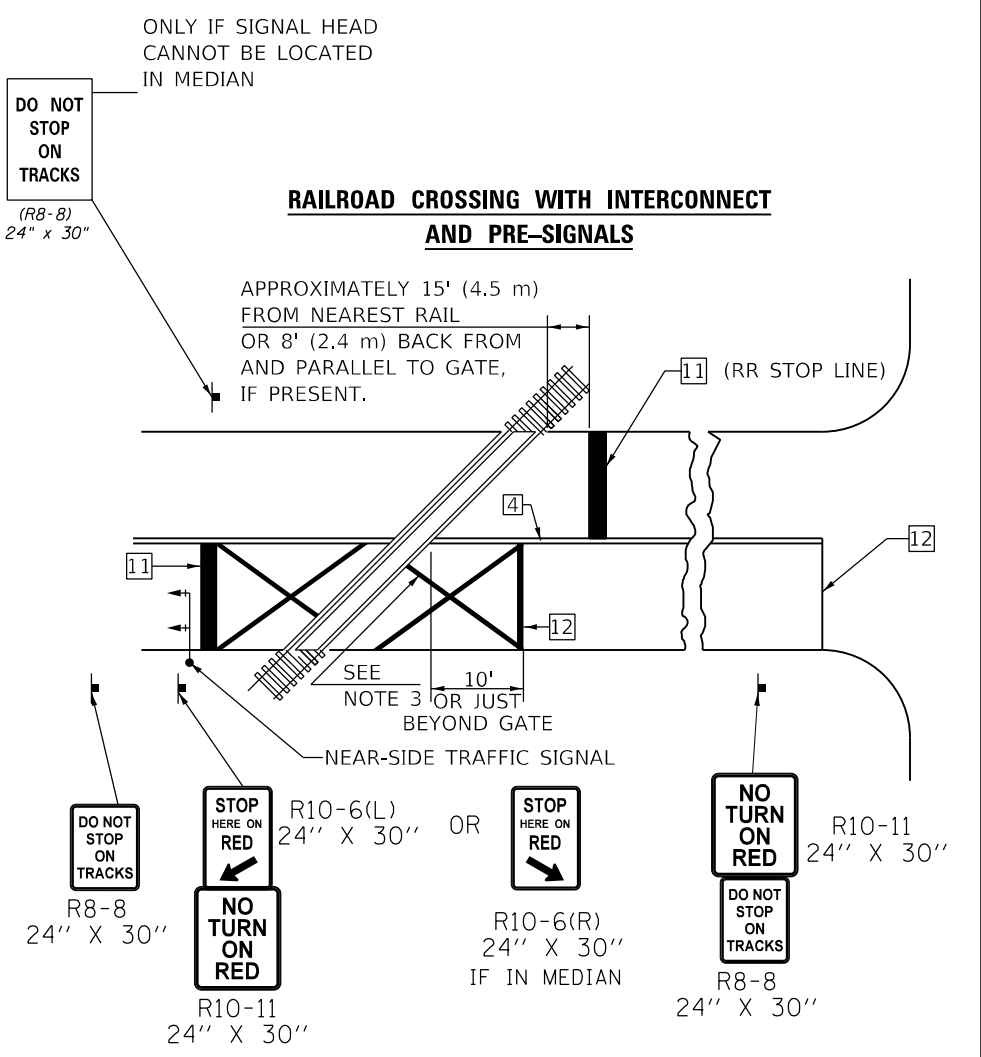
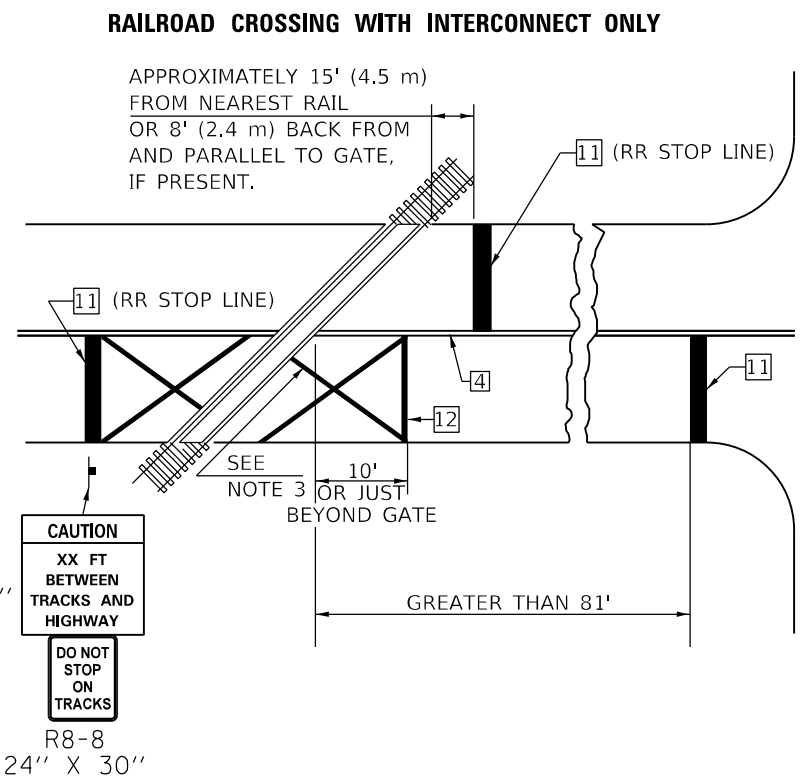
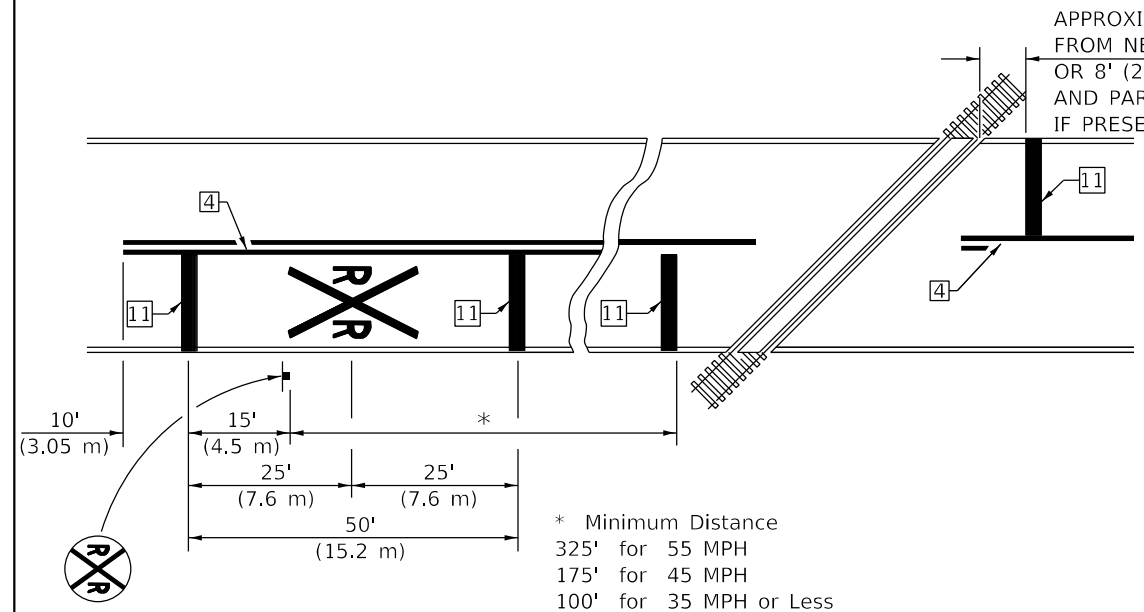

GENERAL NOTES

1. SUPPLEMENTAL PAVEMENT MARKINGS TO BE INSTALLED ONLY ON APPROACHES TO INTERSECTIONS CONTROLLED BY TRAFFIC SIGNALS WHICH ARE INTERCONNECTED WITH THE RAILROAD WARNING SIGNALS.
2. EXTEND PAVEMENT MARKINGS TO THE INTERSECTION ONLY WHERE NEAR-SIDE TRAFFIC SIGNALS ARE USED.
3. 6" WHITE PAVEMENT MARKINGS AT 45° TO PAVEMENT, 8' CENTER TO CENTER.
4. XX DISTANCE TO BE SHOWN ON SIGN MEASURED FROM A POINT 6 FEET FROM THE RAIL CLOSEST TO THE INTERSECTION OR FROM THE CLOSEST POINT ALONG THE EXIT GATE IF PRESENT OVER THE ROADWAY WHEN IN THE LOWERED POSITION TO THE STOP BAR OR CROSSWALK, WHICH EVER IS CLOSEST, ROUNDED DOWN TO NEAREST 5 FEET. WHERE THERE IS NO STOP LINE, MEASURE TO POINT WHERE DRIVER HAS A VIEW OF APPROACHING TRAFFIC.
5. THE CLEARANCE SIGN IS ALSO TO BE USED AS AN INTERIM MEASURE AT LOCATIONS WITH INTERCONNECTED INTERSECTION TRAFFIC SIGNALS WHERE IT IS PLANNED TO CHANGE THEM TO NEAR-SIDE SIGNALS AT A FUTURE TIME. IN THIS CASE, THE DISTANCE TO BE SHOWN ON THE SIGN IS MEASURED FROM THE EDGE OF THE STRIPED-OUT AREA INSTEAD OF 6 FEET FROM THE RAIL. THE SIGN IS TO BE REMOVED WHEN THE NEAR-SIDE SIGNALS ARE INSTALLED AND THE PAVEMENT MARKINGS EXTENDED TO THE INTERSECTION.

SUPPLEMENTAL PAVEMENT MARKING TREATMENT FOR RAILROAD-HIGHWAY GRADE CROSSING

ALTERNATE SIGNS

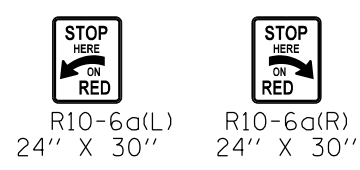

NOTES

THE TRAVERSE SPREAD OF THE "X" MAY VARY ACCORDING TO LANE WIDTH.

ON MULTI-LANE ROADS, THE STOP LINES SHALL EXTEND ACROSS ALL APPROACH LANES AND SEPARATE RXR SYMBOLS SHALL BE PLACED ADJACENT TO EACH OTHER IN EACH LANE.

WHEN THE PAVEMENT MARKING SYMBOL IS USED, A PORTION OF THE SYMBOL SHOULD BE LOCATED DIRECTLY ADJACENT TO THE ADVANCE WARNING SIGN (W10-1) AS PLACED BY TABLE II-1, CONDITION B OF THE MUTCD.

Note: All dimensions are in INCHES (millimeters) unless otherwise shown.

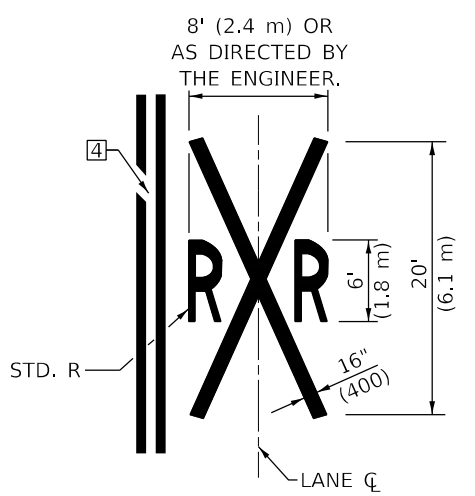

MODEL: Default FILE: MainE: p:\p\lides-cw-behndfey.com\PHWDOT\Documents\DOT Offices\Bentley: S:\Projects\0570E03\CaddData\CaddFiles\0570E03-rh-Detals.dgn

USER NAME = keysmj	DESIGNED -	REVISED - 11/06
	DRAWN -	REVISED - 9/2009 KJT
PLOT SCALE = 40.0000 ' / in.	CHECKED -	REVISED - 04/14 JLA
PLOT DATE = 1/26/2022	DATE -	REVISED - 3/2019 SWN

STATE OF ILLINOIS DEPARTMENT OF TRANSPORTATION

PAVEMENT MARKING AND MARKERS (RURAL & URBAN APPLICATIONS)

SCALE: SHEET 4 OF 4 SHEETS STA. TO STA.

DISTRICT 5 DETAIL NO. 7800AAA				
F.A. RTE.	SECTION	COUNTY	TOTAL SHEETS	SHEET NO.
*	(9,10,11)R5-4,(9-1,9)R5-1	MCLEAN	45	44
FAS 2466 & FAP 676			CONTRACT NO. 70E03	
ILLINOIS		FED. AID PROJECT		

CENTERLINE INTERSTATE OR MULTI-LANE TWO WAY DIVIDED HIGHWAY

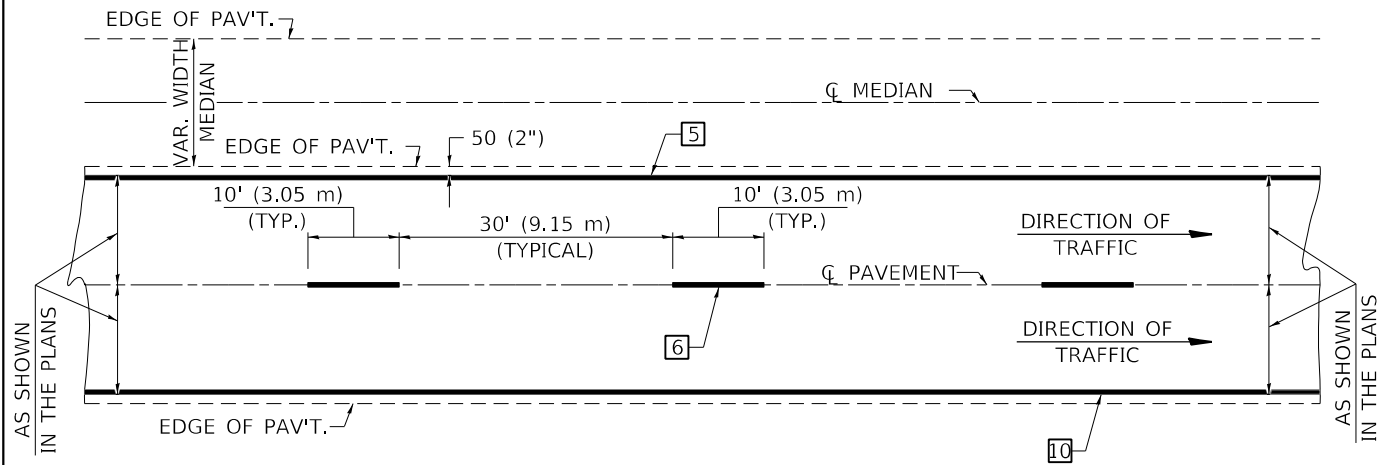

NOTE: PAVEMENT MARKINGS ARE TO BE EXTENDED THROUGH OMISSIONS WHEN APPLICABLE.

NOTE: SEE ARTICLES 780.04 & 781.03 FOR LOCATION OF STRIPES AND MARKERS RELATIVE TO EDGES OR JOINTS.

FOR RAISED REFLECTIVE PAVEMENT MARKERS, REFER TO STANDARD 781001.

TYPICAL PAVEMENT MARKING LEGEND

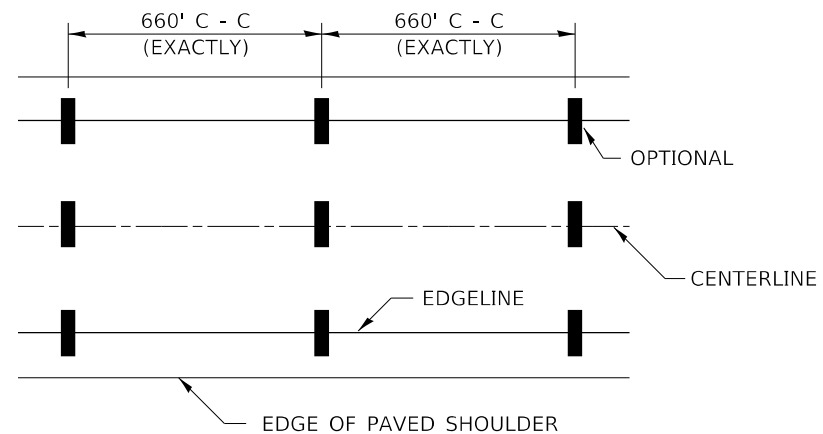

IT WILL BE NECESSARY TO HAVE A REPRESENTATIVE OF THE STATE POLICE PRESENT SO THAT THE ACCURACY OF MEASUREMENT CAN BE ATTESTED TO IN COURT.

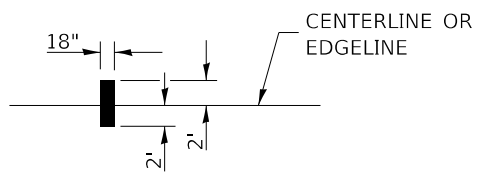

AERIAL SPEED CHECK ZONES

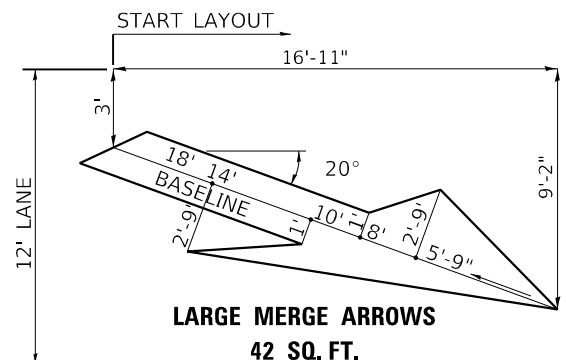

**LARGE MERGE ARROWS
42 SQ. FT.**

- 1 4" (100) SKIP-DASH (YELLOW)
- 2 4" (100) SOLID (YELLOW)
- 3 12" (300) DIAGONAL (YELLOW)
- 4 4" (100) DOUBLE YELLOW (NARROW)
- 5 6" (150) SOLID (YELLOW)
- 6 6" (150) SKIP-DASH (WHITE)
- 7 4" (100) SKIP-DASH (WHITE)
- 8 4" (100) SOLID (WHITE)
- 9 12" (300) DIAGONAL (WHITE)
- 10 6" (150) SOLID (WHITE)
- 11 24" (600) STOP BAR (WHITE)
- 12 8" (200) SOLID (WHITE)
- 13 6" (150) LANE LINE EXTENSIONS (WHITE)

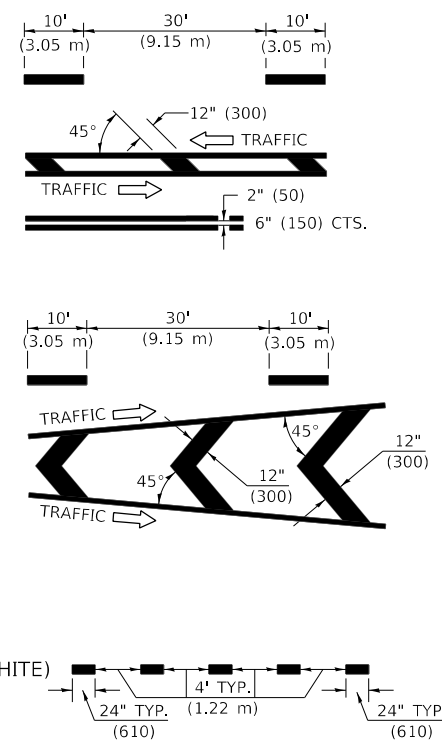

TYPICAL EXIT RAMP TERMINAL

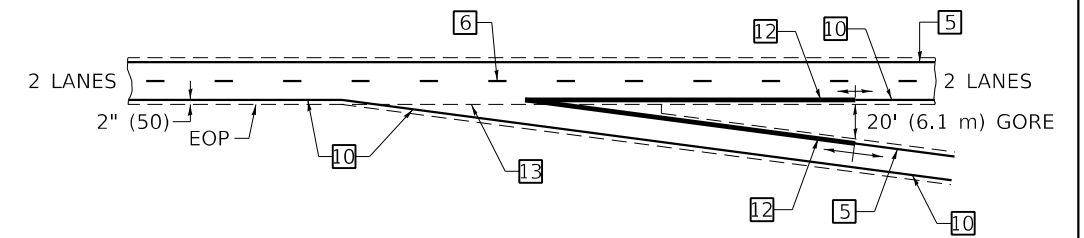

EXIT RAMP TERMINAL with EXCLUSIVE (auxiliary) LANE

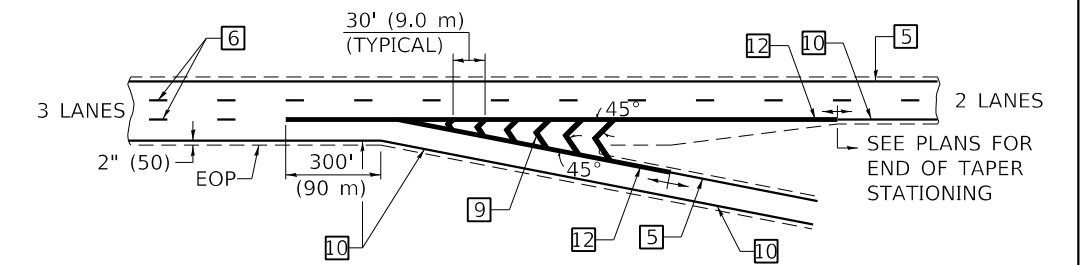

TYPICAL ENTRANCE RAMP TERMINAL

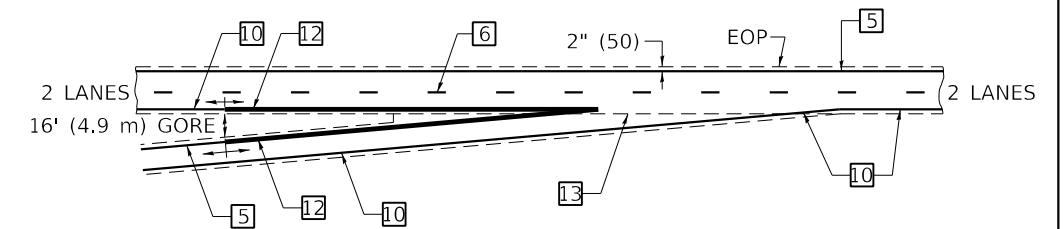

ENTRANCE RAMP TERMINAL with EXCLUSIVE LANE

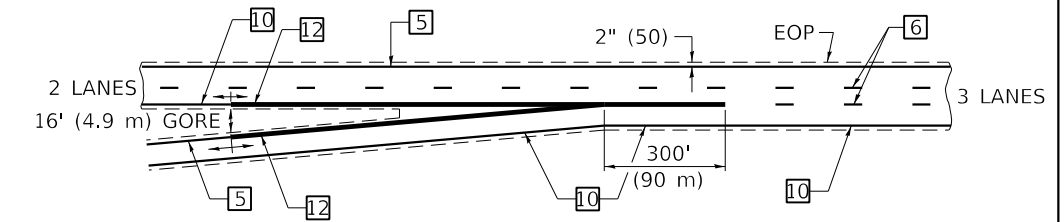

Note: All dimensions are in INCHES (millimeters) unless otherwise shown.

MODEL: D:\default... FILE NAME: P:\projects\7800B\7800B.dgn

USER NAME = keysmj	DESIGNED -	REVISED - 11/06
PLOT SCALE = 40,0000 ' / in.	DRAWN -	REVISED - 12/20
PLOT DATE = 1/26/2022	CHECKED -	REVISED -
	DATE -	REVISED -

**STATE OF ILLINOIS
DEPARTMENT OF TRANSPORTATION**

PAVEMENT MARKING (INTERSTATE & MULTI-LANE APPLICATIONS)

SCALE: SHEET 1 OF 1 SHEETS STA. TO STA.

DISTRICT 5 DETAIL NO. 7800BBBB				
F.A. RTE.	SECTION	COUNTY	TOTAL SHEETS	SHEET NO.
*	(9,10,11)RS-4,(9-1,9)RS-1	MCLEAN	45	45
*FAS 2466 & FAP 676			CONTRACT NO. 70E03	
ILLINOIS FED. AID PROJECT				