

**\*\*EXIST. AGG. SHOULDER LOCATIONS:**  
 AGG. SHLDR., 5' WIDTH  
 STA. 4+38 TO 7+39 (SOUTHBOUND)  
 AGG. SHLDR., 7' WIDTH  
 STA. 7+39 TO 9+05 (SOUTHBOUND)

**\*EXIST. HMA. SHOULDER LOCATIONS:**  
 HMA. SHLDR., 1' WIDTH  
 STA. 7+39 TO 9+05 (SOUTHBOUND)  
 HMA. SHLDR., 3' WIDTH  
 STA. 4+38 TO 7+39 (SOUTHBOUND)

**EXISTING TYPICAL SECTION**  
 STA. 4+38 TO 9+05  
 STA. 35+61 TO 38+40  
 STA. 40+11 TO 43+58  
 STA. 47+01 TO 52+05  
 STA. 53+14 TO 54+58

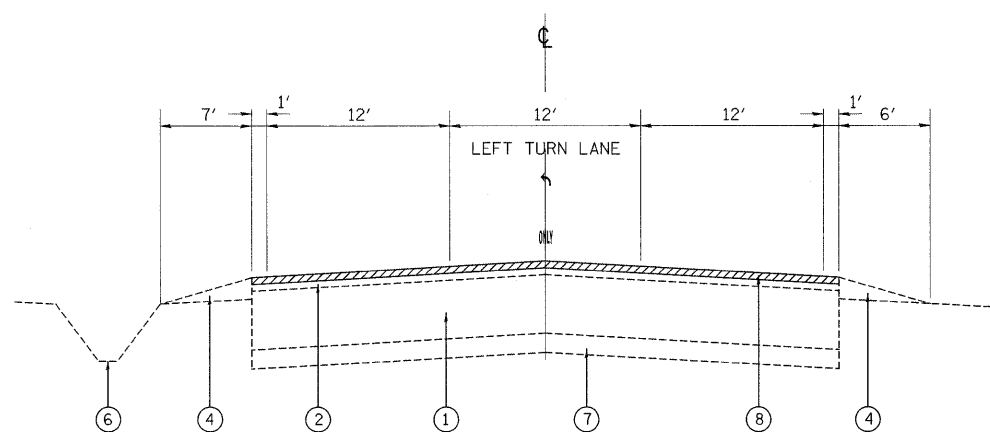

**EXISTING TYPICAL SECTION**  
 STA. 9+05 TO 11+05

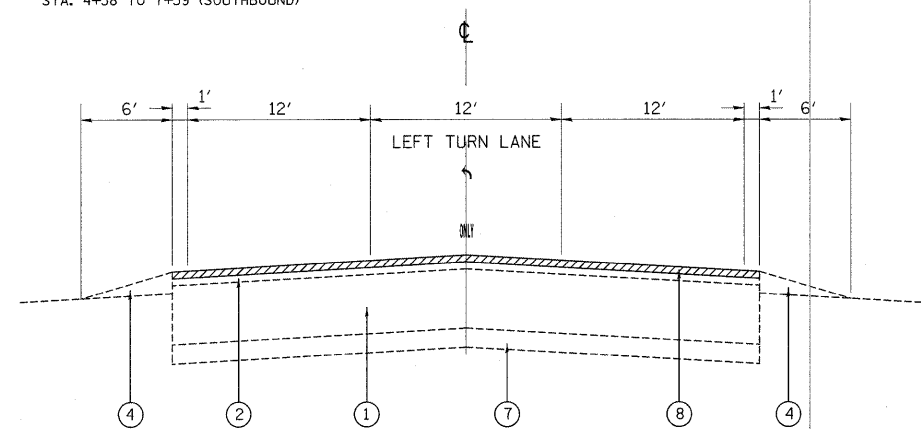

**EXISTING TYPICAL SECTION**  
 STA. 9+05 TO 11+05  
 STA. 39+11 TO 40+11  
 STA. 52+05 TO 53+14  
 STA. 54+58 TO 56+08

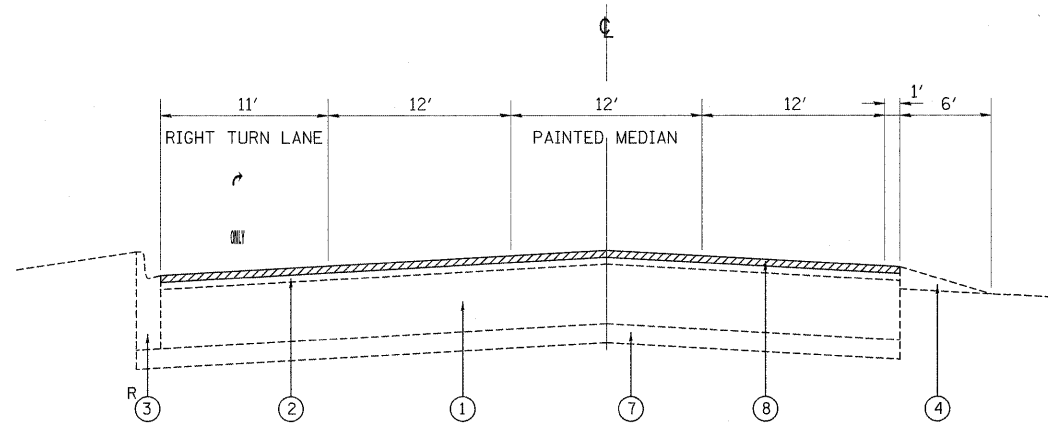

**EXISTING TYPICAL SECTION**  
 STA. 11+05 TO 13+28

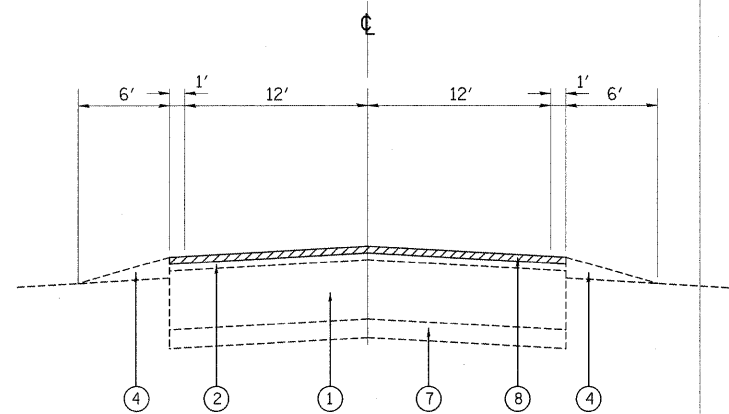

**EXISTING TYPICAL SECTION**  
 STA. 15+37 TO 35+61  
 STA. 43+58 TO 47+01

**LEGEND:**

- ① EXIST. P.C.C. PAVEMENT, ±9"
- ② EXIST. HOT-MIX ASPHALT SURFACE, ±4" (AFTER MILLING)
- ③ EXIST. COMBINATION CONCRETE CURB AND GUTTER, TYPE B-6.12
- ④ EXIST. AGGREGATE SHOULDERS
- ⑤ EXIST. HOT-MIX ASPHALT SHOULDERS
- ⑥ EXIST. DITCH
- ⑦ EXIST. STABILIZED SUB-BASE
- ⑧ PROP. HOT-MIX ASPHALT SURFACE REMOVAL, 2 1/4"
- ⑨ PROP. POLYMERIZED LEVELING BINDER (MACHINE METHOD), IL-4.75, N50, 3/4"
- ⑩ PROP. HOT-MIX ASPHALT SURFACE COURSE, MIX "D", N70, 1 1/2"
- ⑪ PROP. GRADING AND SHAPING SHOULDERS
- ⑫ PROP. GRADING AND SHAPING DITCHES
- ⑬ PROP. AGGREGATE WEDGE SHOULDERS, TYPE B
- ⑭ PROP. TURF REINFORCEMENT MAT
- ⑮ PROP. HOT-MIX ASPHALT SHOULDERS
- R CURB AND GUTTER REMOVAL AND REPLACEMENT

FILE NAME =	USER NAME = steedpa	DESIGNED -	REVISED -	<b>STATE OF ILLINOIS DEPARTMENT OF TRANSPORTATION</b>	EXISTING AND PROPOSED TYPICAL SECTIONS IL 7 (WOLF RD.)--151st ST. TO 143rd ST.			F.A.U. RTE.	SECTION	COUNTY	TOTAL SHEETS	SHEET NO.
c:\pwork\pwork\stedpa\d0146008\107909-shd-plan.dgn	PLOT SCALE = 50,0000' / IN.	DRAWN -	REVISED -					2688	3349 RS-3	COOK	24	4
	PLOT DATE = 11/10/2009	CHECKED -	REVISED -		CONTRACT NO. 60F52			FED. ROAD DIST. NO. 1   ILLINOIS FED. AID PROJECT				
		DATE -	REVISED -		SCALE:	SHEET NO.	OF	SHEETS	STA.	TO	STA.	