

LEGEND:

- ① EXIST. P.C.C. PAVEMENT, ±9"
- ② EXIST. HOT-MIX ASPHALT SURFACE, ±4" (AFTER MILLING)
- ③ EXIST. COMBINATION CONCRETE CURB AND GUTTER, TYPE B-6.12
- ④ EXIST. AGGREGATE SHOULDER, 6'
- ⑤ EXIST. HOT-MIX ASPHALT SHOULDER
- ⑥ EXIST. DITCH
- ⑦ EXIST. STABILIZED SUB-BASE
- ⑧ PROP. HOT-MIX ASPHALT SURFACE REMOVAL, 2 1/4"
- ⑨ PROP. POLYMERIZED LEVELING BINDER (MACHINE METHOD), IL-4.75, N50, 3/4"
- ⑩ PROP. HOT-MIX ASPHALT SURFACE COURSE, MIX "D", N70, 1 1/2"
- ⑪ PROP. GRADING AND SHAPING SHOULDERS
- ⑫ PROP. GRADING AND SHAPING DITCHES
- ⑬ PROP. AGGREGATE WEDGE SHOULDER, TYPE B
- ⑭ PROP. TURF REINFORCEMENT MAT
- ⑮ PROP. HOT-MIX ASPHALT SHOULDER
- R CURB AND GUTTER REMOVAL AND REPLACEMENT

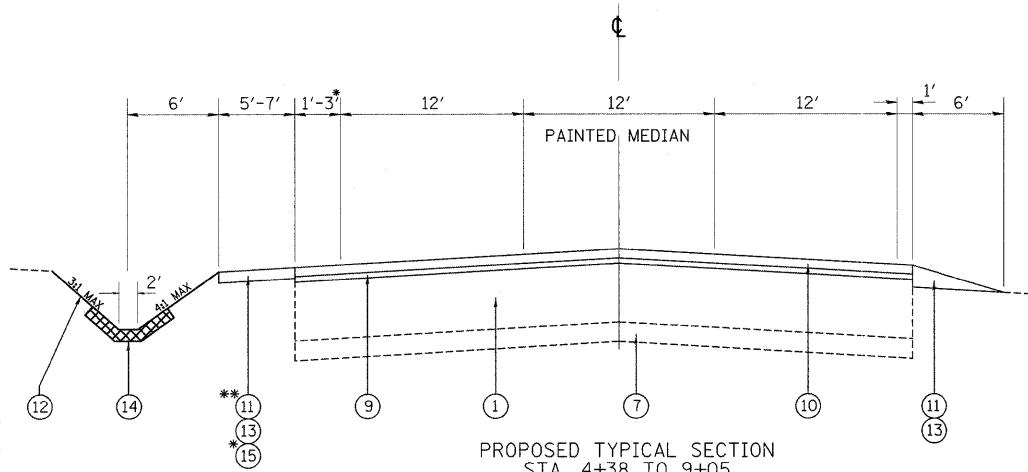

PROPOSED TYPICAL SECTION
 STA. 4+38 TO 9+05
 STA. 35+61 TO 38+40
 STA. 40+11 TO 43+58
 STA. 47+01 TO 52+05
 STA. 53+14 TO 54+58

****PROP. AGG. SHOULDER LOCATIONS:**
 AGG. SHLDR., 5' WIDTH
 STA. 4+38 TO 5+51 (SOUTHBOUND)

***PROP. HMA. SHOULDER LOCATIONS:**
 HMA. SHLDR., 5' WIDTH
 STA. 5+18 TO 7+39 (SOUTHBOUND)
 HMA. SHLDR., 7' WIDTH
 STA. 7+39 TO 9+05 (SOUTHBOUND)

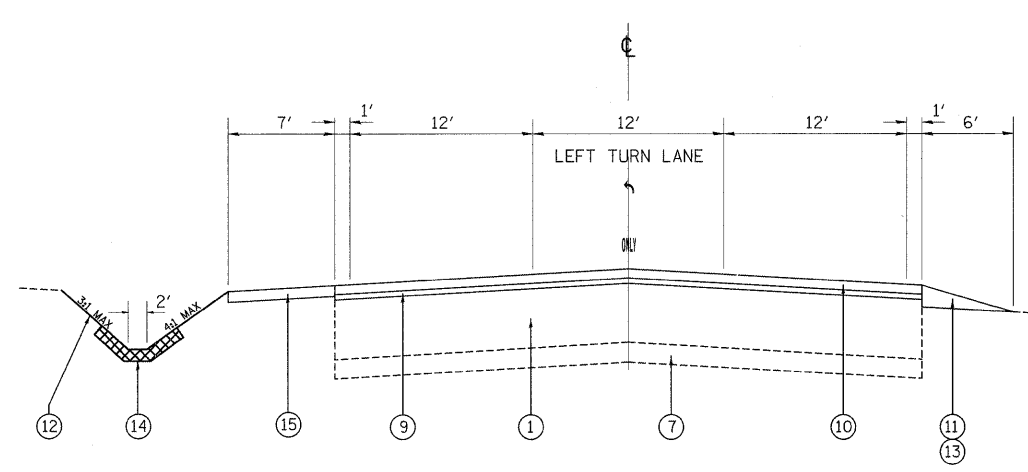

PROPOSED TYPICAL SECTION
 STA. 9+05 TO 11+05

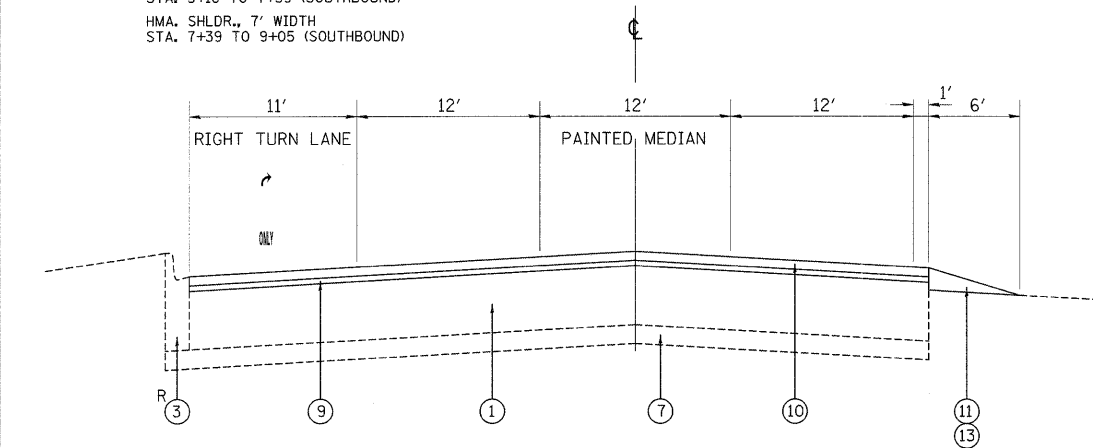

PROPOSED TYPICAL SECTION
 STA. 11+05 TO 13+28

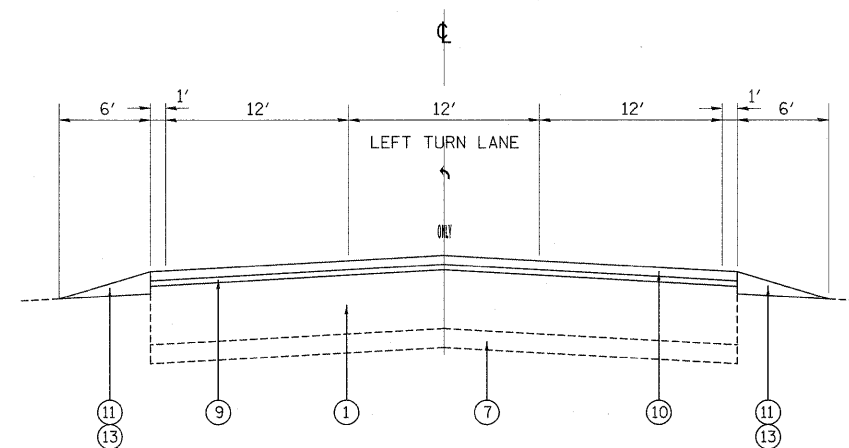

PROPOSED TYPICAL SECTION
 STA. 39+11 TO 40+11
 STA. 52+05 TO 53+14
 STA. 54+58 TO 56+08

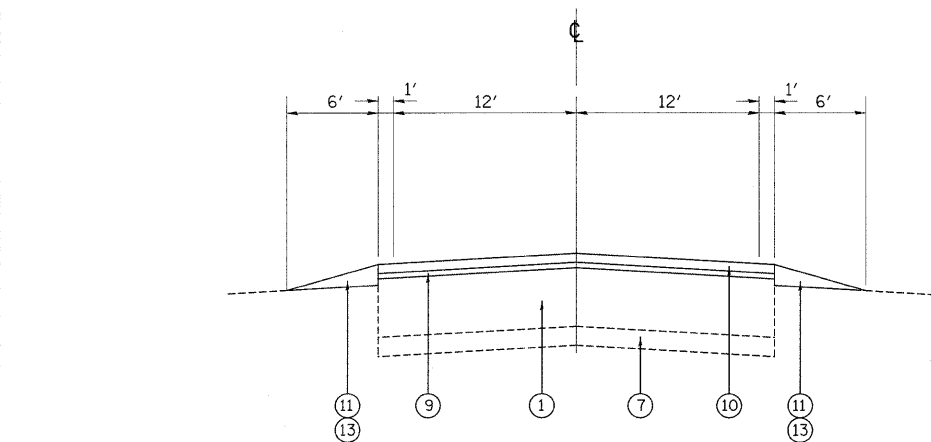

PROPOSED TYPICAL SECTION
 STA. 15+37 TO 35+61
 STA. 43+58 TO 47+01

MIXTURE REQUIREMENTS

MIXTURE USE	DESIGN AIR VOIDS
CLASS "D" PATCHES, 13" HMA BINDER COURSE, IL-19MM	4% @ 70
HOT-MIX ASPHALT SURFACE COURSE, MIX "D", N70, IL 9.5MM	4% @ 70
POLYMERIZED LEVELING BINDER (MACHINE METHOD), IL-4.75, N50	4% @ 50

NOTE:

THE UNIT WEIGHT USED TO CALCULATE ALL HOT-MIX ASPHALT QUANTITIES IS 112 LBS./SQ. YD./ IN.

THE "AC TYPE" FOR POLYMERIZED HMA MIXES SHALL BE "SBS/SBR PG 70 -22" AND FOR NON-POLYMERIZED HMA THE "AC TYPE" SHALL BE "PG 64 -22" UNLESS MODIFIED BY DISTRICT ONE SPECIAL PROVISIONS. FOR "PERCENT OF RAP" SEE DISTRICT ONE SPECIAL PROVISIONS.

THE MILLING SHALL BE DONE PRIOR TO PATCHING

FILE NAME =	USER NAME = steedpa	DESIGNED -	REVISED -	STATE OF ILLINOIS DEPARTMENT OF TRANSPORTATION	EXISTING AND PROPOSED TYPICAL SECTIONS IL 7 (WOLF RD.)--151st ST. TO 143rd ST.	F.A.U. RTE.	SECTION	COUNTY	TOTAL SHEETS	SHEET NO.
es:\pwork\p1dot\stedpa\d0146028\1010909-sht-plan.dgn		DRAWN -	REVISED -			2688	3349 RS-3	COOK	24	5
PLOT SCALE = 50.0000' / IN.		CHECKED -	REVISED -			CONTRACT NO. 60F52				
PLOT DATE = 11/10/2009		DATE -	REVISED -			FED. ROAD DIST. NO. 1 ILLINOIS FED. AID PROJECT				
					SCALE:	SHEET NO.	OF	SHEETS	STA.	TO STA.