

ILL. 1  
EXISTING TYPICAL SECTION  
STA. 35+00 TO STA. 50+35

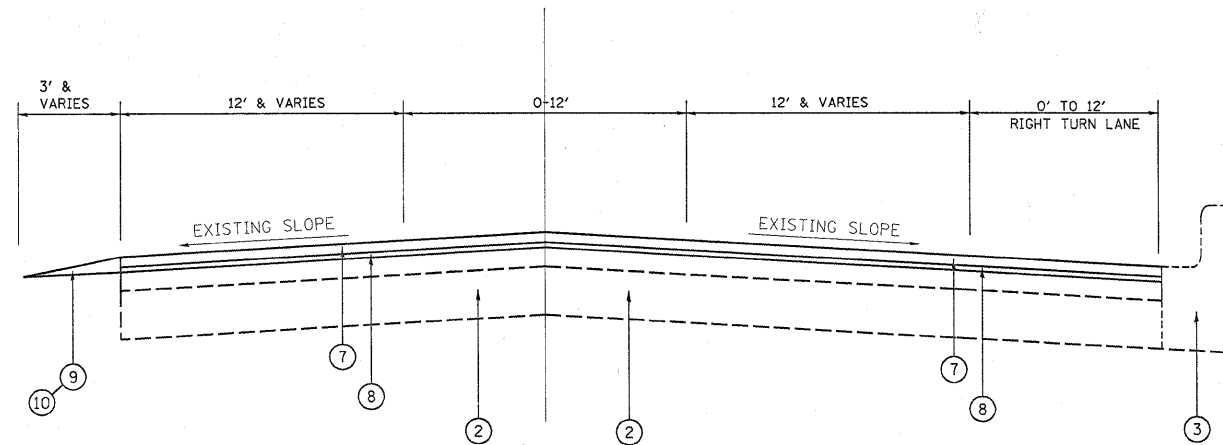

ILL. 1  
PROPOSED TYPICAL SECTION  
STA. 35+00 TO STA. 50+35

LEGEND

- ① EXISTING HOT-MIX ASPHALT SURFACE, 9" (+/-)
- ② EXISTING P.C.C. BASE COURSE, 8" (+/-)
- ③ EXISTING COMBINATION CONCRETE CURB & GUTTER, TYPE B-6.12
- ④ EXISTING HOT-MIX ASPHALT SHOULDER,
- ⑤ EXISTING AGGREGATE SHOULDER
- ⑥ PROPOSED HOT-MIX ASPHALT SURFACE REMOVAL, 2 "
- ⑦ PROPOSED HOT-MIX ASPHALT SURFACE COURSE, MIX "D", N70, 1 1/2 "
- ⑧ PROPOSED POLYMERIZED LEVELING BINDER (MACHINE METHOD), IL-4.5, N50, 3/4"
- ⑨ PROPOSED AGGREGATE WEDGE SHOULDER, TYPE B
- ⑩ PROPOSED GRADING AND SHAPING SHOULDERS
- ⑪ PROPOSED P.C.C. SURFACE REMOVAL (VARIABLE DEPTH)
- ⑫ PROPOSED SHOULDER RUMBLE STRIPS

NOTE:

MILLING TO BE DONE PRIOR TO PATCHING.

FILE NAME =	USER NAME = banks1	DESIGNED -	REVISED -	<b>STATE OF ILLINOIS DEPARTMENT OF TRANSPORTATION</b>	<b>IL. RTE. 1 (CHURCH RD. - ILL. RTE. 394) EXISTING AND PROPOSED TYPICAL CROSS SECTIONS</b>	F.A.U. RTE.	SECTION	COUNTY	TOTAL SHEETS	SHEET NO.	
ca:\pwwork\PWIDOT\BANKSL\d0157014\01035	0-shit-plan.dgn	DRAWN -	REVISED -			332	9 Y-RS-8	WILL	25	6	
	PLOT SCALE = 49.9999' / IN.	CHECKED -	REVISED -			CONTRACT NO. 60140					
	PLOT DATE = 1/29/2010	DATE -	REVISED -			FED. ROAD DIST. NO. 1   ILLINOIS   FED. AID PROJECT					
					SCALE:	SHEET NO. OF SHEETS		STA.	TO STA.		