

SHERIDAN ROAD

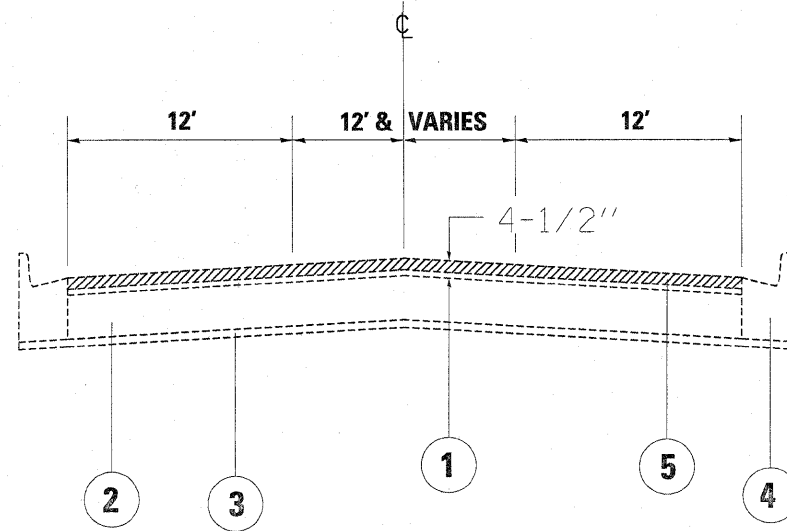

EXISTING TYPICAL CROSS SECTION  
STA. 36+04.5 TO STA. 44+00

LEGEND

- ① EXISTING HOT-MIX ASPHALT OVERLAY, 4 1/2"
- ② EXISTING PORTLAND CEMENT CONCRETE, 8"
- ③ EXISTING SUB-BASE GRANULAR MATERIAL, TYPE A, 4"
- ④ EXISTING CONCRETE CURB AND GUTTER, TYPE B-6.24
- ⑤ PROP. HOT-MIX ASPHALT SURFACE REMOVAL, 2 1/4"
- ⑥ PROP. POLYMERIZED HOT-MIX ASPHALT SURFACE COURSE, MIX "D", N70, 1 1/2"
- ⑦ PROP. POLYMERIZED LEVELING BINDER (MACHINE METHOD), IL-4.75, N50, 3/4"

NOTE: CONTRACTOR IS TO MILL ROADWAY BEFORE PATCHING

SHERIDAN ROAD

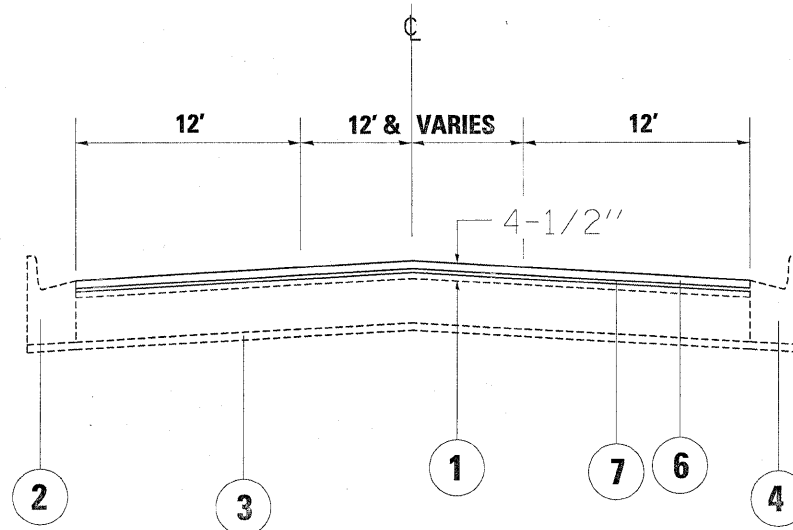

PROPOSED TYPICAL CROSS SECTION  
STA. 36+04.5 TO STA. 44+00

FILE NAME =	USER NAME = byunsh	DESIGNED -	REVISED -	<b>STATE OF ILLINOIS DEPARTMENT OF TRANSPORTATION</b>	<b>SHERIDAN ROAD BUCKLEY ROAD TO MLK BLVD EXISTING AND PROPOSED TYPICAL SECTIONS</b>	F.A.U. RTE.	SECTION	COUNTY	TOTAL SHEETS	SHEET NO.
at:\pwork\PWIDOT\BYUNSH\0173273\011452-Design.dgn	DRAWN -	REVISED -	2744			113R-3-R	LAKE	23	5	
PLOT SCALE = 50.0000' / IN.	CHECKED -	REVISED -	CONTRACT NO. 60J02							
PLOT DATE = 1/28/2010	DATE -	REVISED -	ILLINOIS FED. AID PROJECT							
					SCALE:	SHEET NO.	OF	SHEETS	STA.	TO STA.