

STAGE 1 TYPICAL SECTION - SB BRIDGE

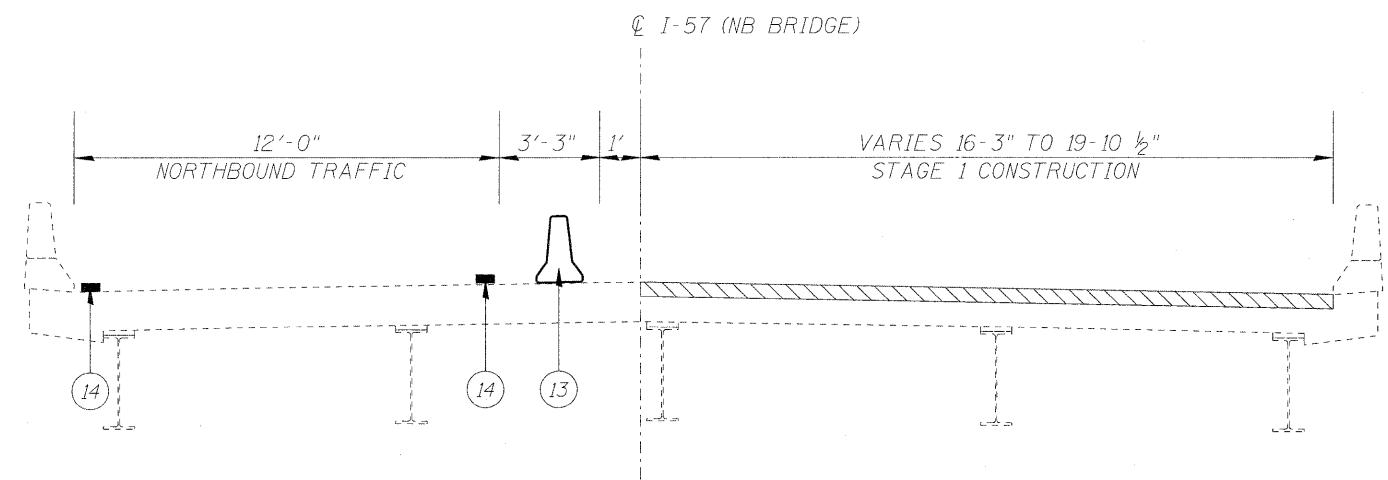

STAGE 1 TYPICAL SECTION - NB BRIDGE

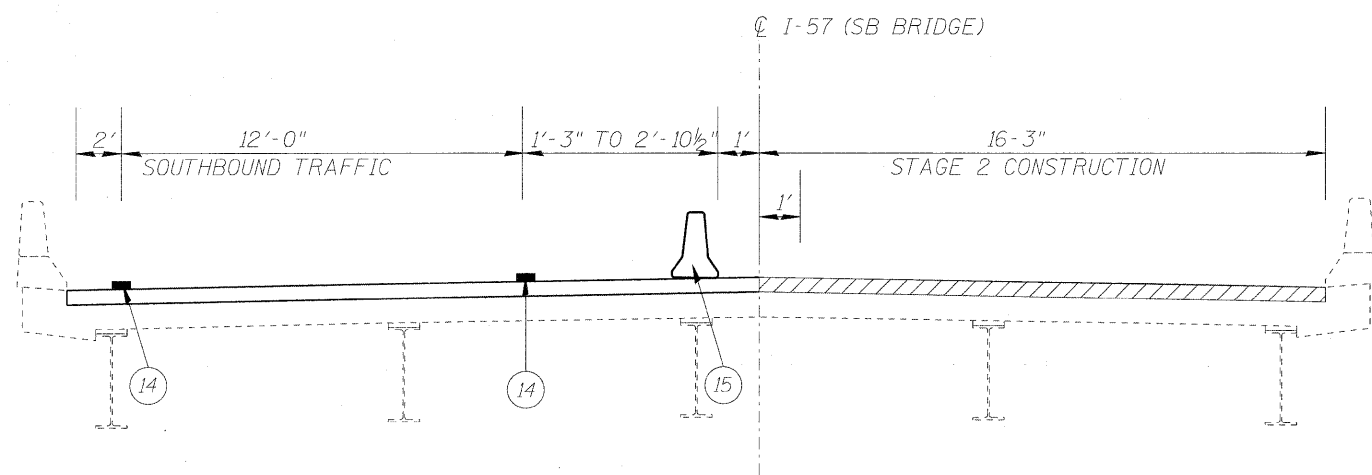

STAGE 2 TYPICAL SECTION- SB BRIDGE

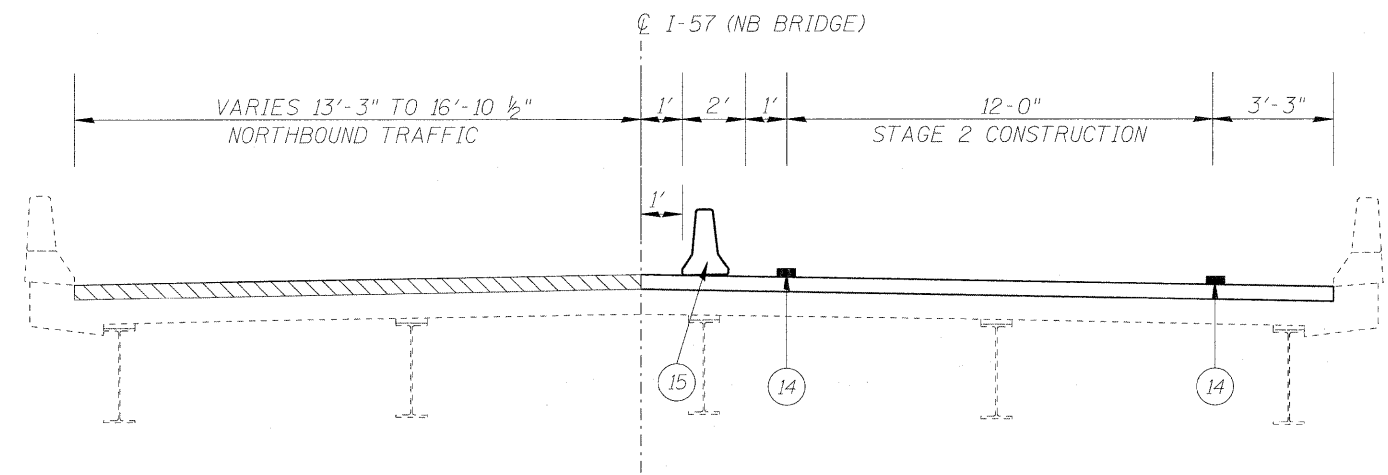

STAGE 2 TYPICAL SECTION- NB BRIDGE

- ⑬ TEMPORARY CONCRETE BARRIER
- ⑭ WET REFLECTIVE TEMPORARY TAPE, TYPE III, 4"
- ⑮ RELOCATE TEMPORARY CONCRETE BARRIER