

STATE OF ILLINOIS
DEPARTMENT OF TRANSPORTATION

ROUTE NO.	SECTION	COUNTY	TOTAL SHEETS	SHEET NO.	SHEET NO. 30
FAP 301	177-2	STEPHENSON	386	170	47 SHEETS
FED. ROAD DIST. NO. 7	ILLINOIS	FED. AID PROJECT-			

Contract No. 64799

WEST ABUTMENT
BILL OF MATERIAL

Bar	No.	Size	Length	Shape
h(E)	20	#5	23'-8"	
h1(E)	14	#5	6'-5"	
h2(E)	14	#5	6'-5"	
h3(E)	26	#4	15'-3"	
h4(E)	18	#4	15'-4"	
h5(E)	10	#6	23'-10"	
n(E)	28	#6	11'-8"	
n1(E)	12	#6	5'-10"	
p(E)	8	#7	48'-4"	
p1(E)	12	#7	16'-1"	
p2(E)	3	#4	16'-5"	
s(E)	66	#4	17'-5"	
s1(E)	34	#4	9'-5"	
s2(E)	18	#4	6'-0"	
u(E)	8	#6	10'-7"	
v(E)	46	#5	3'-2"	
v1(E)	46	#4	3'-6"	
v2(E)	34	#6	8'-1"	
v3(E)	6	#6	8'-1"	
v4(E)	28	#6	8'-3"	
v5(E)	92	#4	6'-9"	
Structure Excavation		Cu. Yd.	253	
Concrete Structures		Cu. Yd.	68.3	
Reinforcement Bars, Epoxy Coated		Pound	5,990	
Furnishing Steel Piles, HP12x53		Foot	600	
Driving Piles		Foot	600	
Test Pile, HP12x53		Each	1	
Pile Shoes		Each	12	
Concrete Encasement		Cu. Yd.	4.6	
Concrete Sealer		Sq. Ft.	173	
Porous Granular Embankment, Special		Cu. Yd.	83	
Geocomposite Wall Drain		Sq. Yd.	38	
Pipe Underdrain for Structures, 4" φ		Foot	53	

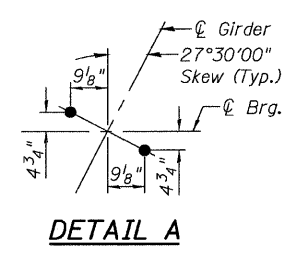
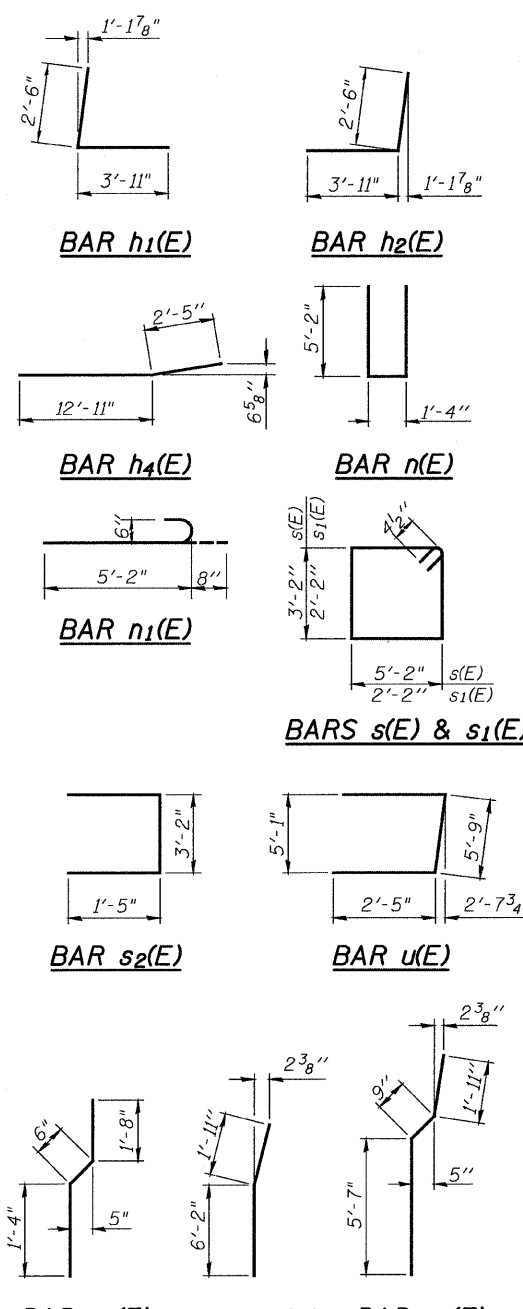
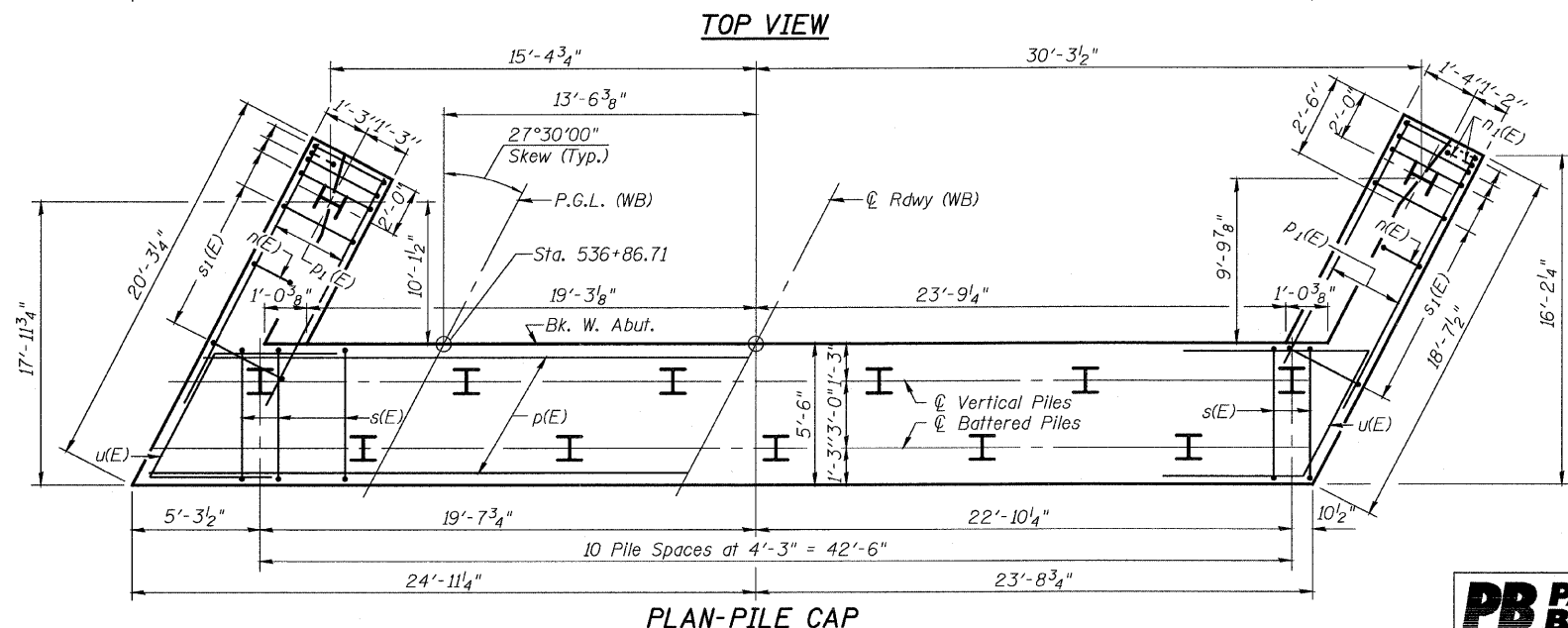
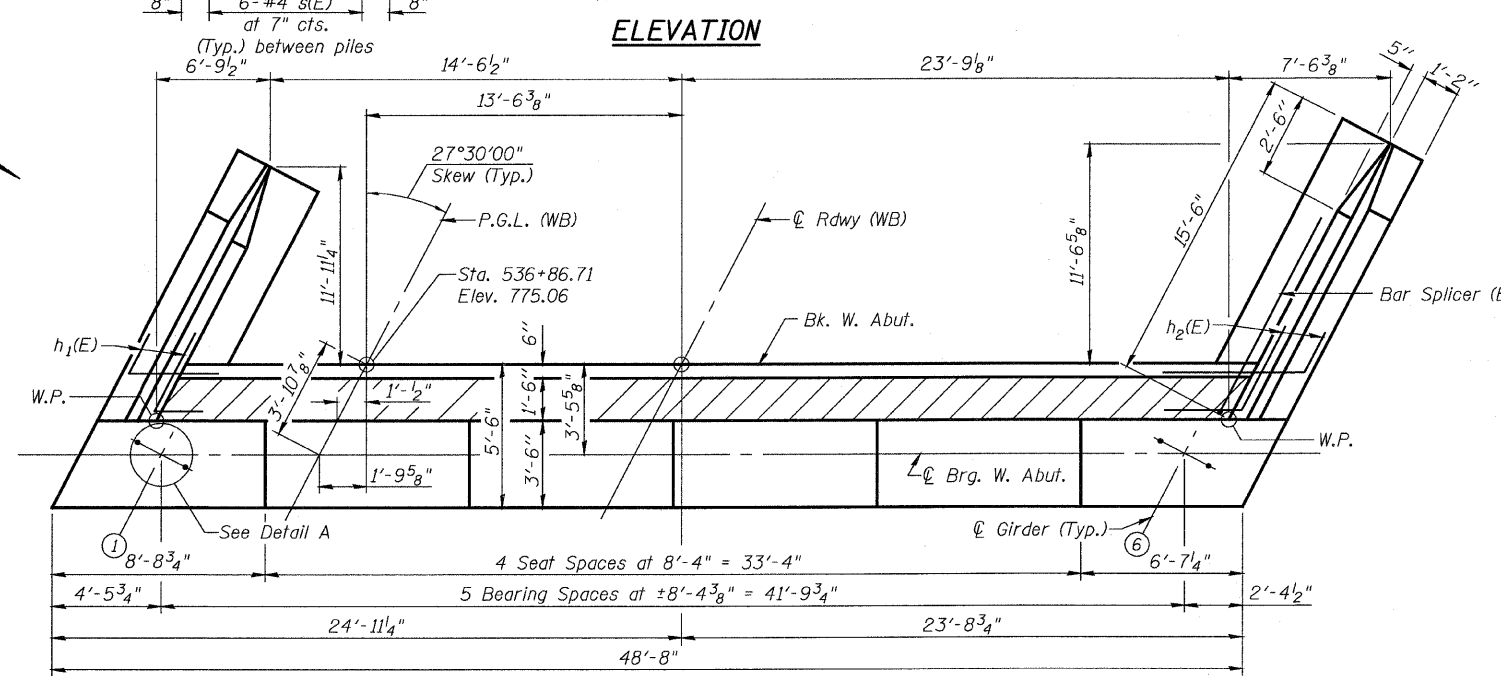
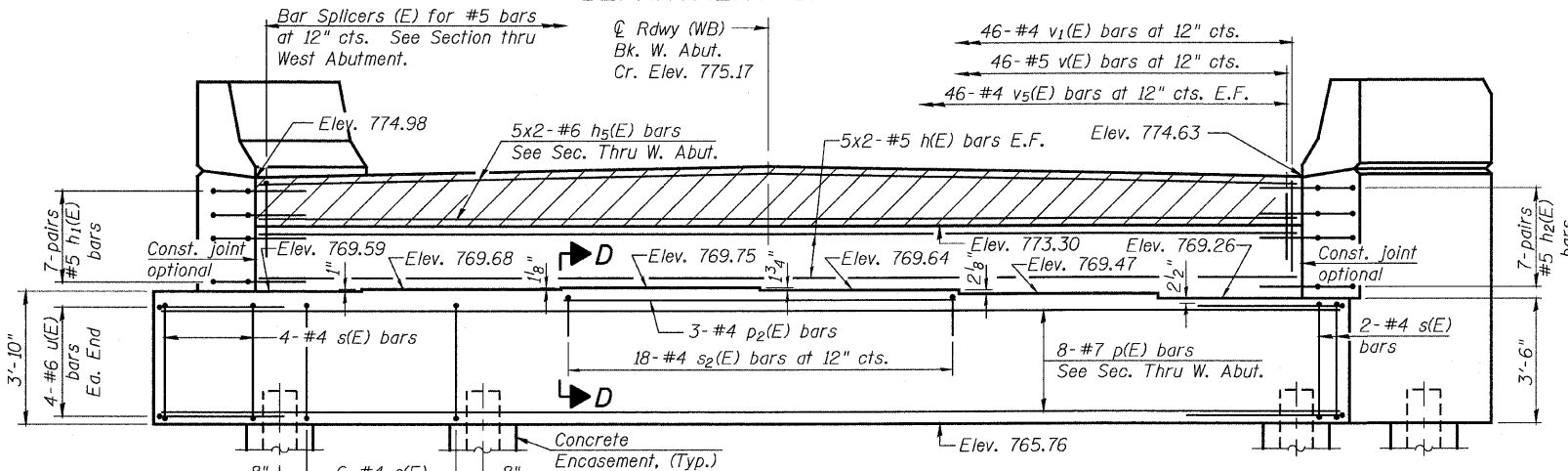

PILE DATA

Type: Steel HP12x53 w/Pile Shoes
Nominal Required Bearing: 419 Kips
Allowable Resistance Available: 120 Kips
Est. Length: 50 Ft.
No. Production Piles: 12
No. Test Piles: 1

DESIGNED	S.CHELBIAN
CHECKED	R.TINGLEY
DRAWN	D.C.PATEL
CHECKED	J.GRAINAWI

Notes:

- For details of Bar Splicers, see Sheet No. 40.
- For details of piles and Concrete Encasement, see Sheet No. 41.
- For details of the Drainage System behind the abutment, see Section Thru Abutment on Sheet No. 2.
- For Section Thru West Abutment & Section D-D, see Sheet No. 31.
- Work this sheet with Sheet No. 31.

MINIMUM BAR LAP

#5 bar = 2'-2"
#6 bar = 2'-7"

WEST ABUTMENT
E.A.P. ROUTE 301 SECTION 177-2B-1
STEPHENSON COUNTY
STATION 540+65.71
STRUCTURE NO. 089-0082



T:\18914\AS\StructCada\PreFinal\US20 Bridge 089-0082 (Pecatonica River Bridge)\000000-64799-000-030-030.dgn 25-JAN-2010 13:47