

STATE OF ILLINOIS  
DEPARTMENT OF TRANSPORTATION

BEAM REACTIONS

RP	(K)	46.5
Rt	(K)	54.4
Imp.	(K)	12.1
R (Total)	(K)	113.0

Notes:  
Diaphragm removal and reinstallation may be required to facilitate drilling holes. Cost included with Furnishing and Erecting Structural Steel.  
New steel extensions, shim plates and connection bolts are included with Furnishing and Erecting Structural Steel.  
Prior to ordering any material, the Contractor shall verify in the field all bearing height and shim thickness dimensions. Min. Jack capacity = 60 Tons.  
Anchor bolts shall be ASTM F1554 all-thread (or an Engineer-approved alternate material) of the grade(s) and diameter(s) specified. ASTM A307 Grade C anchor bolts may be used in lieu of ASTM F1554 Grade 36 (Fy=36ksi). The corresponding specified grade of AASHTO M314 anchor bolts may be used in lieu of ASTM F1554.

Drilled and set anchor bolts shall be installed according to Article 521.06 of the Standard Specifications.  
Side retainers shall be included in the cost of Elastomeric Bearing Assembly, Type I.  
If the analysis submitted to the Contractor for the jacking/temporary support system to be used shows temporary stiffeners are required to prevent web crippling or buckling, the stiffeners shall be steel and bolted to the web. If stiffeners are not required, hardwood timbers shall be installed tightly between the top and bottom flange to prevent flange rotation.

All structural steel shall be shop painted with the inorganic zinc rich primer per AASHTO M300, Type I. Cost included with Furnishing and Erecting Structural Steel.

Existing structural steel that will be in contact with new structural steel shall be cleaned and painted prior to erection as required by the Special Provision "Cleaning and Painting Contact Surface Areas of Existing Steel Structures".  
The existing structural steel coating contains lead. The Contractor shall take appropriate precautions to deal with the presence of lead on this project.

All structural steel shall conform to AASHTO Classification M-270 Gr. 36, unless otherwise noted.  
Fasteners shall be high strength bolts.

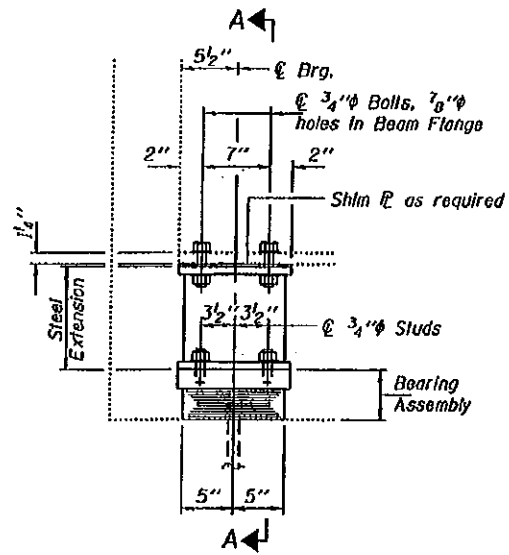

ELEVATION AT ABUTMENT

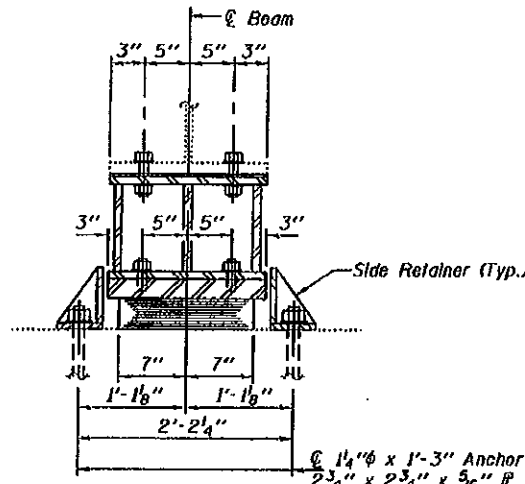

SECTION A-A

TYPE I ELASTOMERIC EXP. BRG.

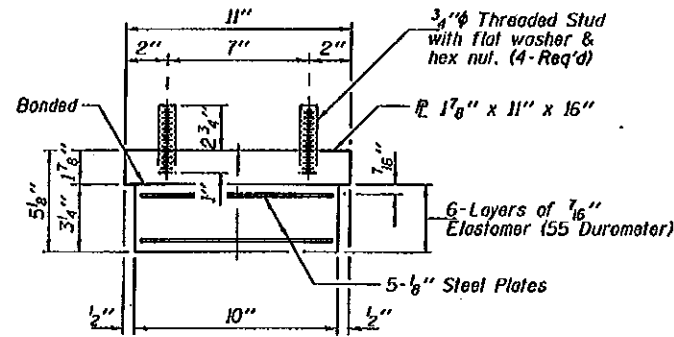

BEARING ASSEMBLY

Note:  
Shim plates shall not be placed under Bearing Assembly.

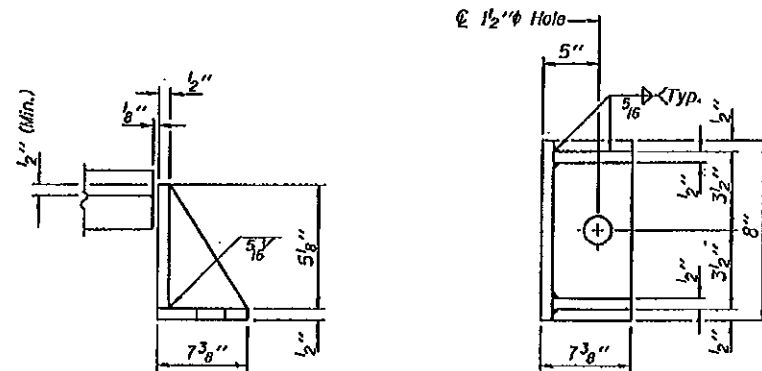

SIDE RETAINER

Equivalent rolled angle with stiffeners will be allowed in lieu of welded plates. (40 Required)

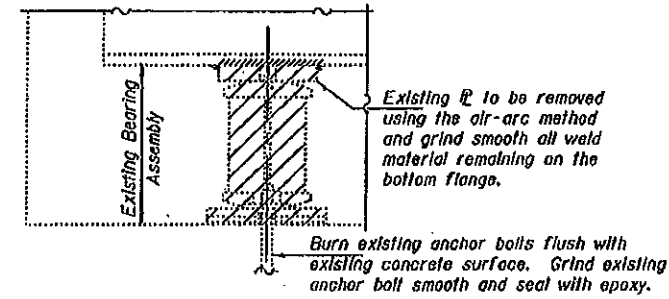

EXISTING BEARING REMOVAL DETAIL

Cost included with Jack and Remove Existing Bearings.

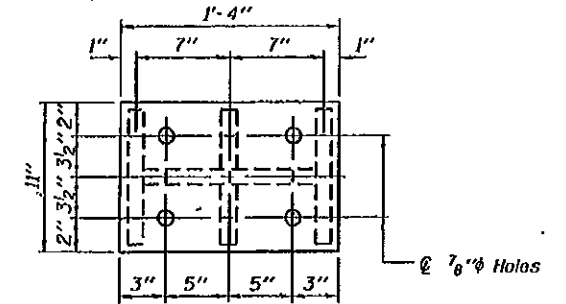

PLAN TOP AND BOTTOM PLATE

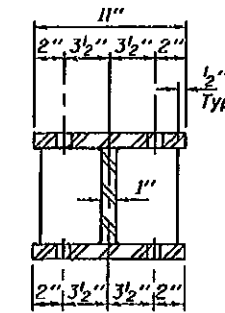

SECTION B-B

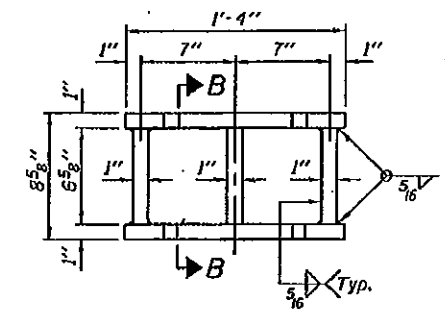

STEEL EXTENSION DETAIL

BILL OF MATERIAL

Item	Unit	Total
Elastomeric Bearing Assembly, Type I	Each	20
Jack and Remove Existing Bearings	Each	20
Furnishing and Erecting Structural Steel	Pound	3700
Anchor Bolts 1 1/4 inch	Each	40

ELASTOMERIC BEARING ASSEMBLY DETAILS  
SN 074-0055

DESIGNED	VHV
CHECKED	DAB
DRAWN	Kyle M. Steffen
CHECKED	VHV DAB

OCTOBER 5, 2009  
EXAMINED  
PASSED

PRE-FINAL  
DATE: 10-05-2009

TYI/REPS 12-03-2008

SHEET NO.	F.A.I. RTE.	SECTION	COUNTY	TOTAL SHEETS	SHEET NO.
- SHEETS	72	-	PIATT	251	144
FED. ROAD DIST. NO.			ILLINOIS FED. AID PROJECT		
CONTRACT NO.					