

MILLING TRANSITION DETAILS

TAPER DETAIL

LAKE LAWRENCE INTERCHANGE

RAMP A	
15A+01.22	TO 15A+36.22
RAMP B	
77B+02.50	TO 77B+37.50
RAMP C	
0C+08.08	TO 0C+43.08
RAMP D	
75D+74.44	TO 76D+09.44
RAMP E	
10E+47.38	TO 10E+82.38

LAKE LAWRENCE INTERCHANGE

RAMP A	
0A+00.00	TO 0A+20.00
RAMP B	
88B+38.92	TO 88B+58.92
RAMP C	
10C+16.75	TO 10C+36.75
RAMP D	
88D+98.95	TO 89D+18.95

US 50 EASTBOUND

940+06.81	TO	940+21.81
965+45.68	TO	965+60.68
967+66.86	TO	967+81.86
984+91.79	TO	985+06.79
987+15.96	TO	987+30.96
1063+50.00	TO	1063+65.00

US 50 WESTBOUND

940+06.81	TO	940+21.81
965+24.14	TO	965+39.14
967+45.32	TO	967+60.32
984+91.79	TO	985+06.79
987+15.96	TO	987+30.96
1063+50.00	TO	1063+65.00

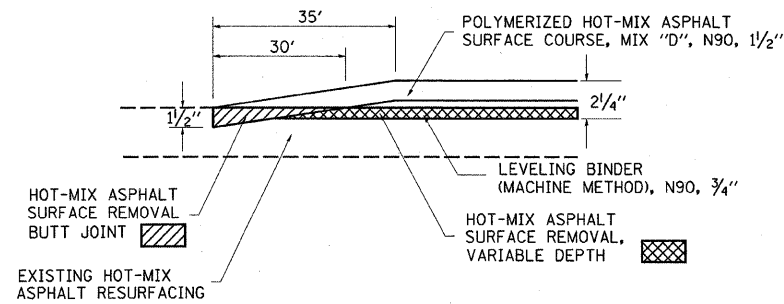

BUTT JOINT DETAIL

US 50 EASTBOUND		US 50 WESTBOUND	
806+34.43	TO 806+64.43	806+34.43	TO 806+64.43
849+14.81	TO 849+44.81	849+14.81	TO 849+44.81
851+45.19	TO 851+75.19	851+45.19	TO 851+75.19
864+08.89	TO 864+38.89	863+75.11	TO 864+05.11
865+50.89	TO 865+80.89	865+17.11	TO 865+47.11
935+23.19	TO 935+53.19	935+23.19	TO 935+53.19

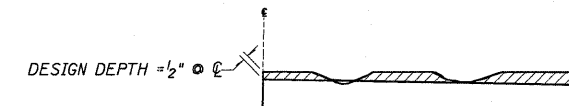

NOTES:

- MILLING SHALL BE DONE TO ATTAIN A 3/6" SLOPE IN CROWN SECTIONS
- EXISTING S.E. AND S.E. TRANSITIONS SHALL BE MAINTAINED UNLESS OTHERWISE SHOWN ON THE PLANS.
- MILLING TO THE BOTTOM OF WHEEL RUTS SHALL NOT BE NECESSARY UNLESS REQUIRED TO OBTAIN SLOPE OR THE DESIGN DEPTH AT CENTERLINE.
- THE AVERAGE DEPTH OF MILLING IS ESTIMATED TO BE 1/2" BUT MAY VARY IN ISOLATED LOCATIONS.

HOT-MIX ASPHALT SURFACE REMOVAL (VARIABLE DEPTH) DETAIL

NOTE: DETAILS NOT DRAWN TO SCALE

FILE NAME =	USER NAME = swartzw	DESIGNED -	REVISED -	STATE OF ILLINOIS DEPARTMENT OF TRANSPORTATION	MISC. JOB DETAILS			F.A.P. RTE.	SECTION	COUNTY	TOTAL SHEETS	SHEET NO.
ca:\pw_work\PWIDOT\SWARTZRW\d0138979\d7	4398-sht-details.dgn	DRAWN -	REVISED -					327	.	LAWRENCE	49	38
PLOT SCALE = 50.0000' / IN.		CHECKED -	REVISED -		SCALE: NA	SHEET NO. 1 OF 5 SHEETS	STA.	TO STA.	ILLINOIS FED. AID PROJECT			
PLOT DATE = 1/28/2010		DATE -	REVISED -									

(51-24)RS-3 & (51-24-2)RS-1