

**PROPOSED HMA RESURFACING
SUPERELEVATED SECTION**
STA. 244+33 TO STA. 254+09

- LEGEND**
- ① EXISTING PCC PAVEMENT
 - ② EXISTING HMA RESURFACING
 - ③ EXISTING 1' SAFETY SHOULDER
 - ④ PROPOSED 3/4" MILLING
 - ⑤ PROPOSED HMA SC "C" N70 1 1/2"
 - ⑥ PROPOSED LEVEL BINDER MM N70
 - ⑦ PROPOSED BIT MATL PRIME COAT
 - ⑧ PROPOSED AGG. PRIME COAT
 - ⑨ PROPOSED HMA SHOULDER 6"
 - ⑩ PROPOSED AGG. WEDGE SHLDR TYPE "B"
 - ⑪ PROPOSED STRIP REFLECTIVE CRACK CONTROL

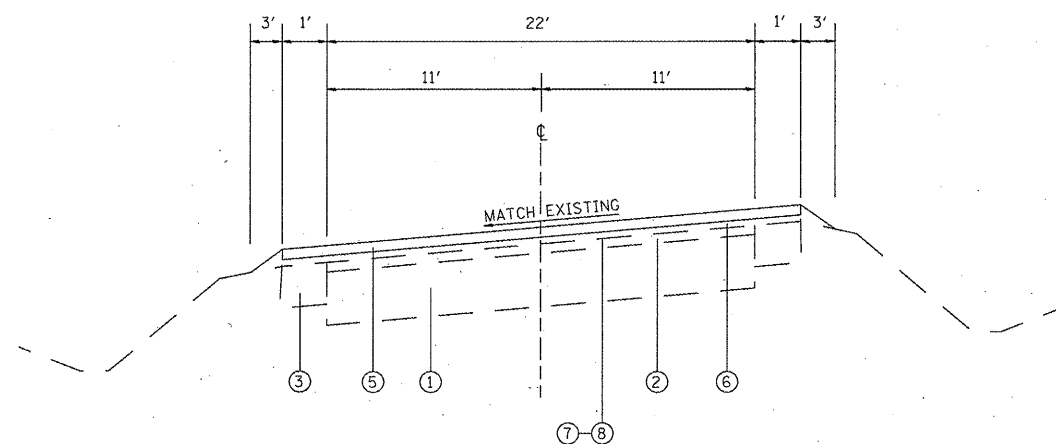

**PROPOSED HMA RESURFACING FOR MILLED
SUPERELEVATED SECTION**
STA. 12+25 TO STA. 24+59
STA. 49+44 TO STA. 59+85

FILE NAME =	USER NAME = *USER*	DESIGNED -	REVISED -	STATE OF ILLINOIS DEPARTMENT OF TRANSPORTATION	TYPICAL SECTIONS	F.A.S. RTE.	SECTION	COUNTY	TOTAL SHEETS	SHEET NO.	
#FILE#		DRAWN -	REVISED -			2780	128 RS-2	CLINTON	14	8	
	PLOT SCALE = *SCALE*	CHECKED -	REVISED -			CONTRACT NO. 76D82					
	PLOT DATE = *DATE*	DATE -	REVISED -			FED. ROAD DIST. NO. ILLINOIS FED. AID PROJECT					