

63RD STREET  
EXISTING TYPICAL SECTION  
 STA. 7+88 TO STA. 28+65

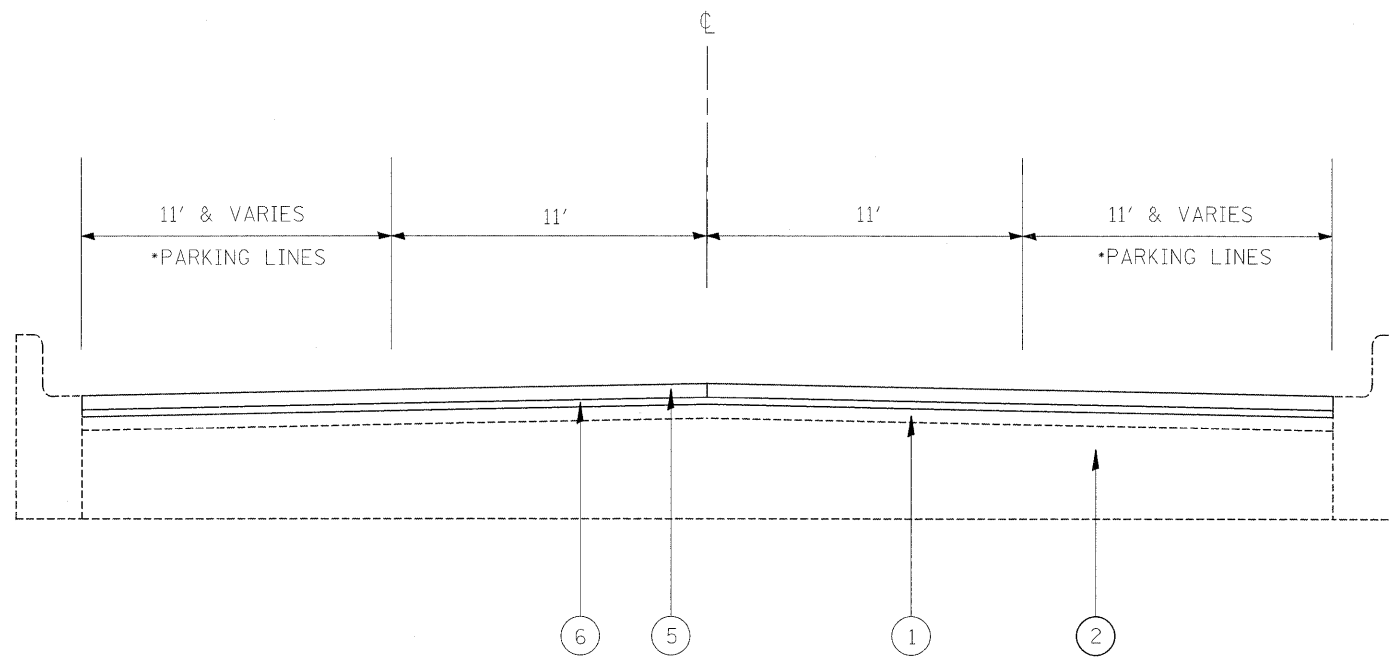

63RD STREET  
PROPOSED TYPICAL SECTION  
 STA. 7+88 TO STA. 28+65

LEGEND

- ① EXISTING HOT-MIX ASPHALT SURFACE, 3" (+/-)
- ② EXISTING CONCRETE BASE COURSE, 9" (+/-)
- ③ EXISTING COMBINATION CONCRETE CURB & GUTTER, TYPE B-6.12
- ④ PROPOSED HOT-MIX ASPHALT SURFACE REMOVAL, 2 1/4"
- ⑤ PROPOSED HOT-MIX ASPHALT SURFACE COURSE, MIX "D", N70, 1 1/2"
- ⑥ PROPOSED POLYMERIZED LEVELING BINDER (MACHINE METHOD), IL-4.5, N50, 3/4"

\* PATCHING TO BE DONE PRIOR TO MILLING

\* PARKING LANES SHOWN ON ROADWAY PLANS.

FILE NAME = ct:\pwwork\pwwid01\BANKSL\08110634\sh...dgn	USER NAME = banks1	DESIGNED -	REVISED -	<b>STATE OF ILLINOIS DEPARTMENT OF TRANSPORTATION</b>	<b>63RD STREET- ILL. 171 TO ILL. 43 EXISTING AND PROPOSED TYPICAL CROSS SECTIONS</b>	F.A.P. RTE. 1519	SECTION 2008-032 RS	COUNTY COOK	TOTAL SHEETS 21	SHEET NO. 5
PLOT SCALE = 49.9999' / IN.	CHECKED -	REVISED -	SCALE:			SHEET NO. OF SHEETS STA. TO STA.	FED. ROAD DIST. NO. 1 ILLINOIS FED. AID PROJECT			
PLOT DATE = 3/25/2009	DATE -	REVISED -	CONTRACT NO. 60E72							