

EXISTING TYPICAL SECTION
STA. 143+55.7 TO STA 146+10

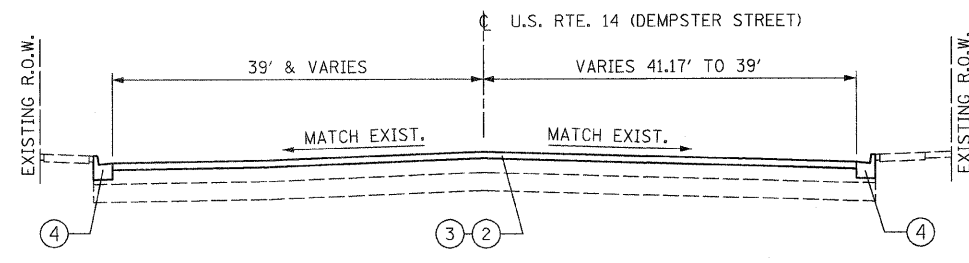

PROPOSED TYPICAL SECTION
STA. 143+55.7 TO STA 146+10

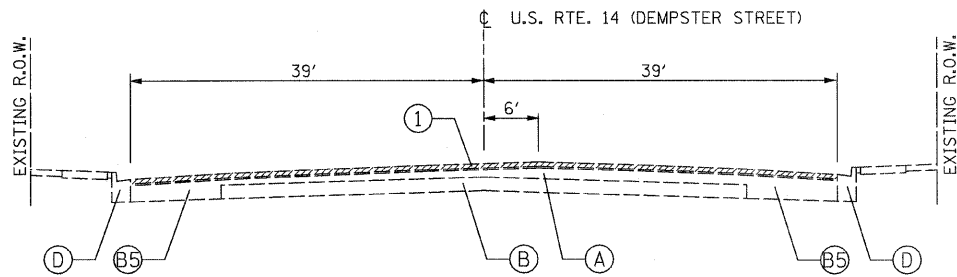

EXISTING TYPICAL SECTION
STA. 146+10 TO STA 176+33

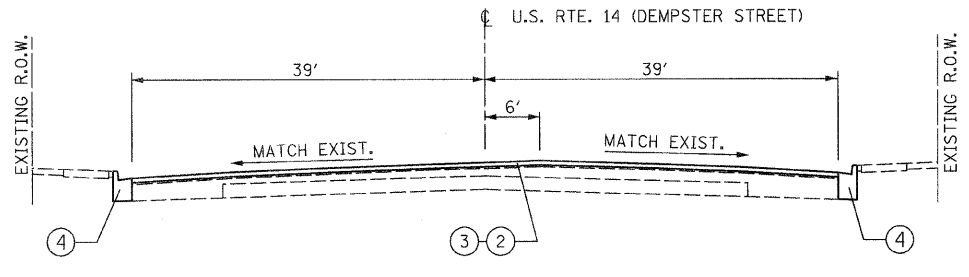

PROPOSED TYPICAL SECTION
STA. 146+10 TO STA 176+33

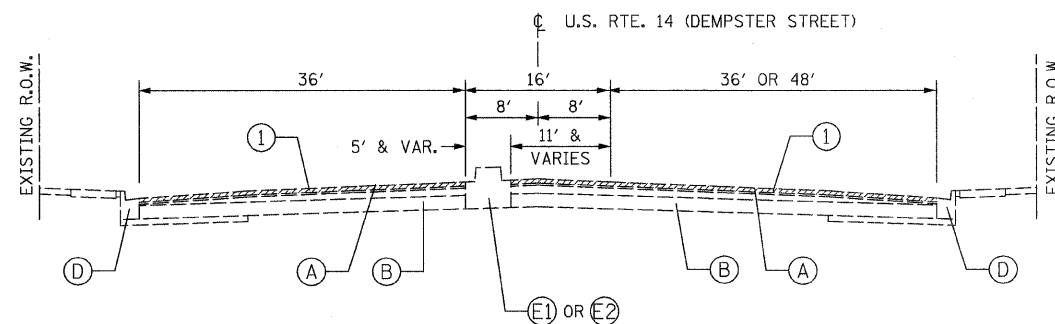

EXISTING TYPICAL SECTION
STA. 176+25 TO STA. 209+14

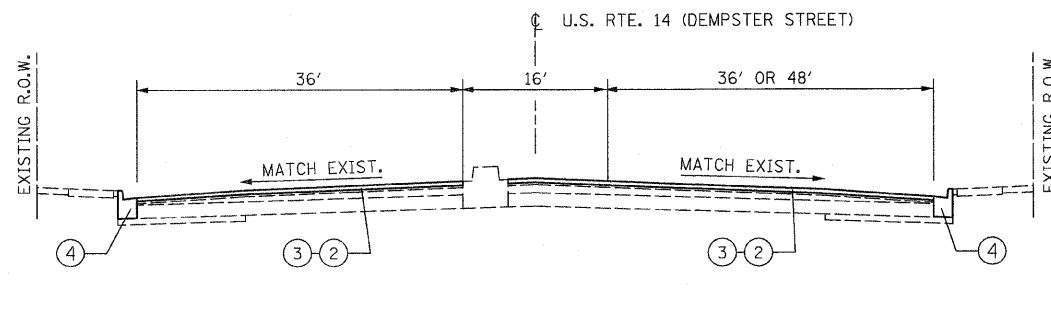

PROPOSED TYPICAL SECTION
STA. 176+25 TO STA. 209+14

EXISTING CONDITIONS:

- (A) HOT-MIX ASPHALT SURFACE AND BINDER COURSE, 5", 7" & VARIES
- (B) P.C. CONCRETE PAVEMENT, 9"
- (B1) P.C. CONCRETE BASE COURSE, 8' OR 9"
- (B2) HOT MIX ASPHALT BASE COURSE, 12"
- (B3) HOT MIX ASPHALT PAVEMENT (FULL DEPTH), 15 1/2"
- (B4) HOT MIX ASPHALT PAVEMENT (FULL DEPTH), 15 3/4"
- (B5) HOT MIX ASPHALT PAVEMENT (FULL DEPTH)
- (C) AGGREGATE SUBGRADE, 4", 6" AND VARIES
- (C1) AGGREGATE SUBGRADE, 12"
- (D) COMBINATION CONCRETE CURB & GUTTER, TYPE B-6.24
- (D1) COMBINATION CONCRETE CURB & GUTTER, TYPE B-6.18
- (D2) COMBINATION CONCRETE CURB & GUTTER, TYPE B-6.12
- (E) CONCRETE MEDIAN, TYPE SB-6.06
- (E1) CONCRETE MEDIAN, TYPE SB-6.12
- (E2) CONCRETE MEDIAN, TYPE SM-2.12
- (F) TIE BAR

PROPOSED IMPROVEMENTS:

- (1) HOT-MIX ASPHALT SURFACE REMOVAL, 2 1/2"
- (1A) HOT-MIX ASPHALT SURFACE REMOVAL, 1 3/4"
- (2) POLYMERIZED HOT-MIX ASPHALT SURFACE COURSE, MIX "F", N90, 1 3/4"
- (3) POLYMERIZED LEVELING BINDER (MACHINE METHOD), IL-4.75, N50, 3/4"
- (4) COMB. CONC. CURB AND GUTTER REMOVAL AND REPLACEMENT (LOCATION AS DETERMINED BY THE ENGINEER)

NOTE:

THE CONTRACTOR SHALL MILL FIRST BEFORE PATCHING.

FILE NAME = D160F26-ah-typ001.dgn
PLOT DATE = 3/30/2009



DESIGNED - G.F.L.	REVISED -
DRAWN - B.K.	REVISED -
CHECKED - M.P.	REVISED -
DATE - MARCH 2009	REVISED -

STATE OF ILLINOIS
DEPARTMENT OF TRANSPORTATION

TYPICAL SECTIONS
US 14 (DEMPSTER STREET) GRACE AVE. TO ILL 43 (WAUKEGAN RD.)

SCALE: NONE SHEET NO. 3 OF 3 SHEETS STA. 143+55.7 TO STA. 215+14

F.A.U. RTE. 1324	SECTION 3228 D-Z-Y-RS-1	COUNTY COOK	TOTAL SHEETS 32	SHEET NO. 6
FED. ROAD DIST. NO. 1 ILLINOIS FED. AID PROJECT				CONTRACT NO. 60F26