

GOLF ROAD / SIMPSON STREET

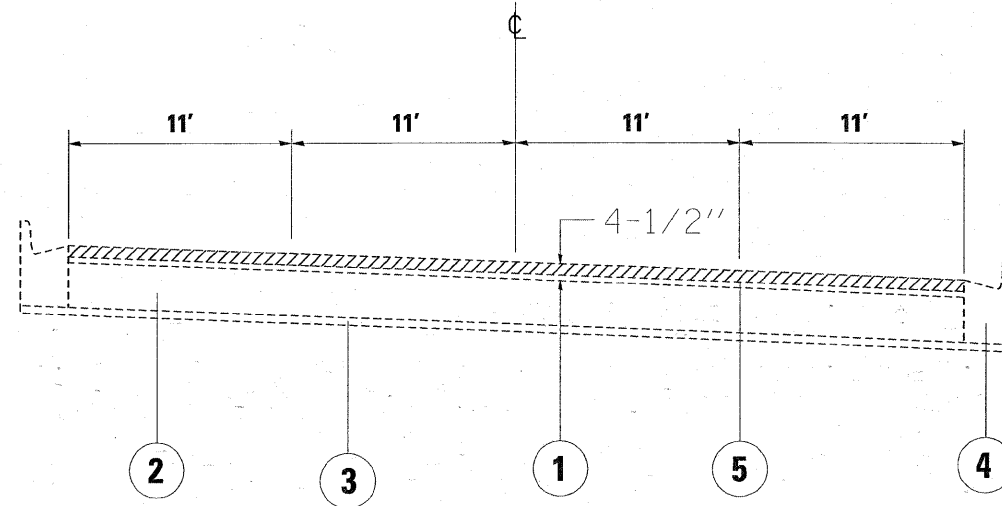

EXISTING TYPICAL CROSS SECTION  
STA. 73+63 TO STA. 77+32

GOLF ROAD / SIMPSON STREET

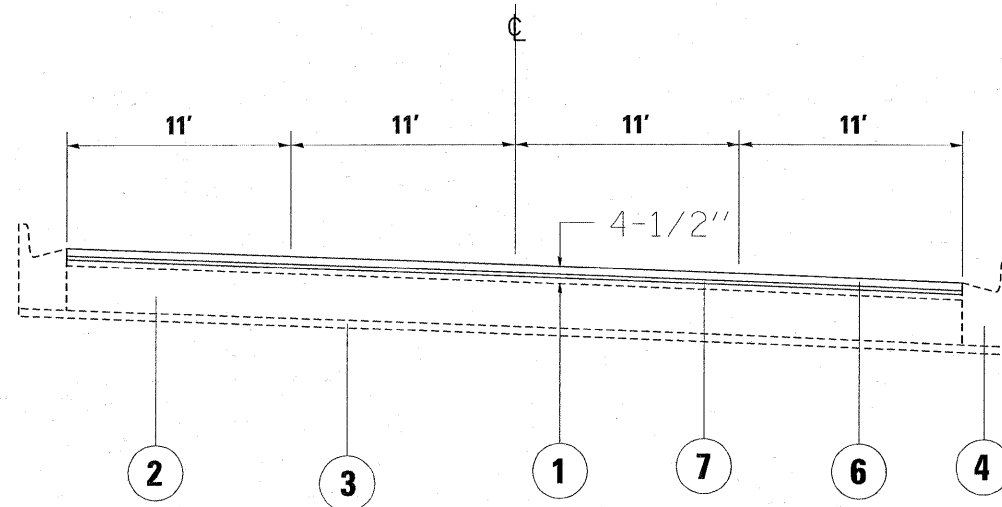

PROPOSED TYPICAL CROSS SECTION  
STA. 73+63 TO STA. 77+32

LEGEND

- ① EXISTING HOT-MIX ASPHALT OVERLAY, 4 1/2"
- ② EXISTING PORTLAND CEMENT CONCRETE, 8"
- ③ EXISTING SUB-BASE GRANULAR MATERIAL, TYPE A, 4"
- ④ EXISTING CONCRETE CURB AND GUTTER, TYPE B-6.24
- ⑤ PROP. HOT-MIX ASPHALT SURFACE REMOVAL, 2 1/2"
- ⑥ PROP. POLYMERIZED HOT-MIX ASPHALT SURFACE COURSE, MIX "F", N90, 1 3/4"
- ⑦ PROP. POLYMERIZED LEVELING BINDER (MACHINE METHOD), IL-4.75, N50, 3/4"

NOTE: CONTRACTOR IS TO MILL ROADWAY BEFORE PATCHING

FILE NAME =	USER NAME = byunsh	DESIGNED -	REVISED -	<b>STATE OF ILLINOIS DEPARTMENT OF TRANSPORTATION</b>	<b>GOLF ROAD / SIMPSON STREET GROSS POINT ROAD TO McCORMICK BLVD EXISTING AND PROPOSED TYPICAL SECTIONS</b>			F.A.U RTE. 1312	SECTION 2009-052 RS	COUNTY COOK	TOTAL SHEETS 27	SHEET NO. 6
et\p\work\PM100T\BYUNSH\d0136979\0125694-Design.dgn		DRAWN -	REVISED -		SCALE:	SHEET NO.	OF	SHEETS	STA.	TO STA.	CONTRACT NO. 60G89	
		CHECKED -	REVISED -								ILLINOIS FED. AID PROJECT	
		DATE -	REVISED -									