

MILLED TEMPORARY RAMP  
(FOR BUTT JOINT AND HMA TAPER SEE DETAIL BELOW)

**OPTION 1**

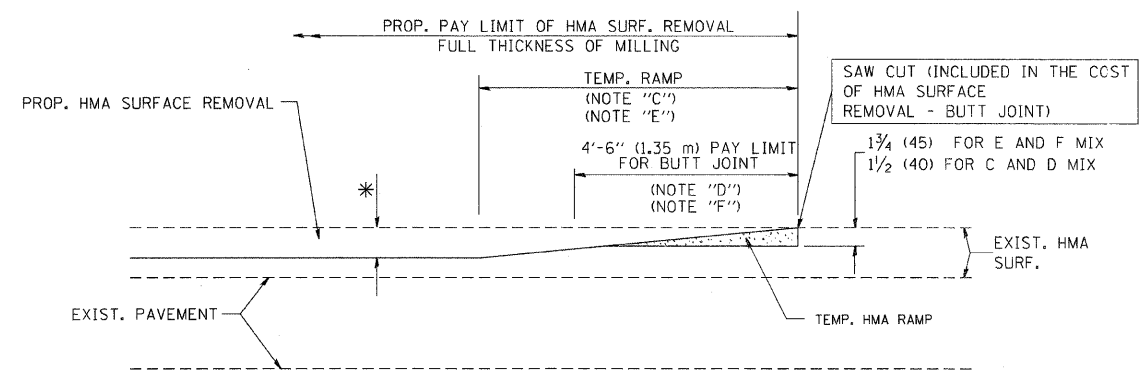

HMA CONSTRUCTED TEMPORARY RAMP  
(FOR BUTT JOINT AND HMA TAPER SEE DETAIL BELOW)

**OPTION 2**

**TYPICAL TEMPORARY RAMP**

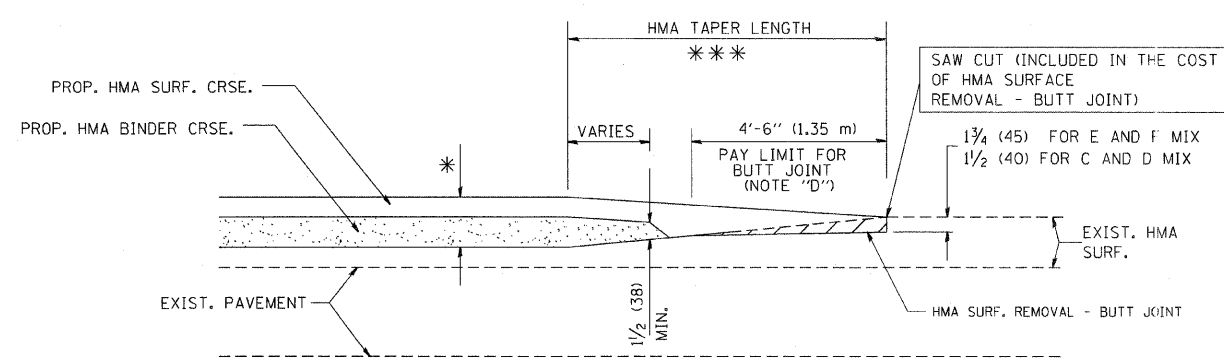

BUTT JOINT AND  
HMA TAPER

**TYPICAL BUTT JOINT AND HMA TAPER  
FOR MILLING AND RESURFACING**

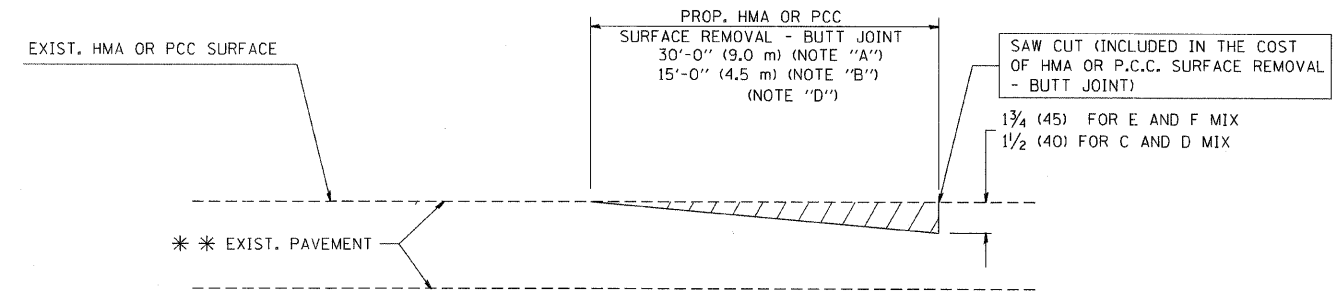

BUTT JOINT DETAIL

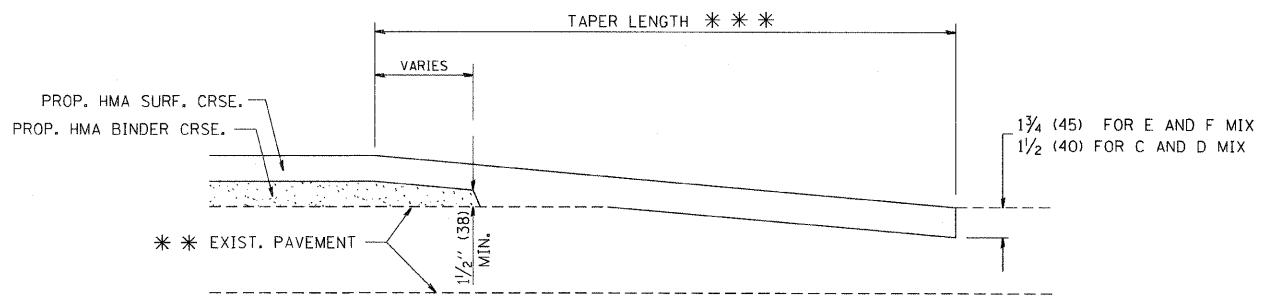

HMA TAPER DETAIL

**TYPICAL BUTT JOINT AND HMA TAPER  
FOR RESURFACING ONLY**

\*\*\* PC CONCRETE, HMA OR HMA RESURFACED PAVEMENT.

**NOTES**

- A: MAINLINE ROADWAYS AND MAJOR SIDE ROADS.
- B: MINOR SIDE ROADS.
- C: THE TEMP. RAMP SHALL BE CONSTRUCTED IMMEDIATELY UPON REMOVAL OF THE EXISTING HMA SURFACE.
- D: THE BUTT JOINT SHALL BE CONSTRUCTED IMMEDIATELY PRIOR TO PLACING THE PROPOSED HMA COURSES.
- E: TAPER THE TEMP. RAMP AT A RATE OF 3'-0" (900 mm) PER 1 INCH (25 mm) OF MILLING THICKNESS.
- F: INSTALLATION AND REMOVAL OF THE 4'-6" (1.35 m) TEMP. RAMP IS INCLUDED IN COST OF HMA SURFACE REMOVAL - BUTT JOINT
- G: SEE ARTICLE 406.08 AND 406.14 OF THE STANDARD SPECIFICATIONS FOR "HMA AND/OR PCC SURFACE REMOVAL, BUTT JOINT".
- \* SEE TYPICAL SECTIONS FOR MILLING THICKNESS.
- \*\*\* 20'-0" (6.1 m) PER 1 (25) RESURFACING (NOTE "A")  
10'-0" (3.0 m) PER 1 (25) RESURFACING (NOTE "B")

**BASIS OF PAYMENT:**

THE BUTT JOINT WILL BE PAID FOR AT THE CONTRACT UNIT PRICE PER SQUARE YARD (SQUARE METER) FOR "HOT-MIX ASPHALT SURFACE REMOVAL - BUTT JOINT" OR FOR "PORTLAND CEMENT CONCRETE SURFACE REMOVAL - BUTT JOINT".

ALL DIMENSIONS ARE IN INCHES (MILLIMETERS) UNLESS OTHERWISE SHOWN.

FILE NAME = W:\distatd\22x34\bd32.dgn	USER NAME = goglionobt	DESIGNED - M. DE YONG	REVISED - R. SHAH 10-25-94	<b>STATE OF ILLINOIS DEPARTMENT OF TRANSPORTATION</b>	<b>BUTT JOINT AND HMA TAPER DETAILS</b>	F.A.U. R.T.E. 1549	SECTION BR-RS	COUNTY COOK	TOTAL SHEETS 13	SHEET NO. 9	
PLOT SCALE = 50.0000' / IN.	CHECKED -	REVISOR - A. ABBAS 03-21-97	SCALE: NONE			SHEET NO. 1 OF 1 SHEETS	STA. TO STA.	<b>BD400-05 BD32</b>			
PLOT DATE = 1/4/2008	DATE - 06-13-90	REVISOR - M. GOMEZ 04-06-01				CONTRACT NO. 60H42					
		REVISOR - R. BORO 01-01-07				FED. ROAD DIST. NO. 1 ILLINOIS FED. AID PROJECT					