

F.A.U. RTE.	SECTION	COUNTY	TOTAL SHEETS	SHEET NO.
3592	(707, 707.1 & 708) RS-11	COOK	19	1
FED. ROAD DIST. NO.	ILLINOIS	CONTRACT NO. 62405		

**STATE OF ILLINOIS  
DEPARTMENT OF TRANSPORTATION  
DIVISION OF HIGHWAYS**

**PROPOSED  
HIGHWAY PLANS**

**FAU ROUTE 3592 (BRAINARD AVE.)  
SECTION: (0707, 0707.1 & 0708) RS-11  
S/O 130TH ST. TO N/O BURNHAM AVE.  
RESURFACING (3P)**

**COOK COUNTY  
C-91-087-02**



FOR INDEX OF SHEETS, SEE SHEET NO. 2

**PROJECT LOCATED IN  
THE CITY OF CHICAGO**

**TRAFFIC DATA**  
2006 ADT = 13,100  
POSTED SPEED LIMIT = 30-35 MPH

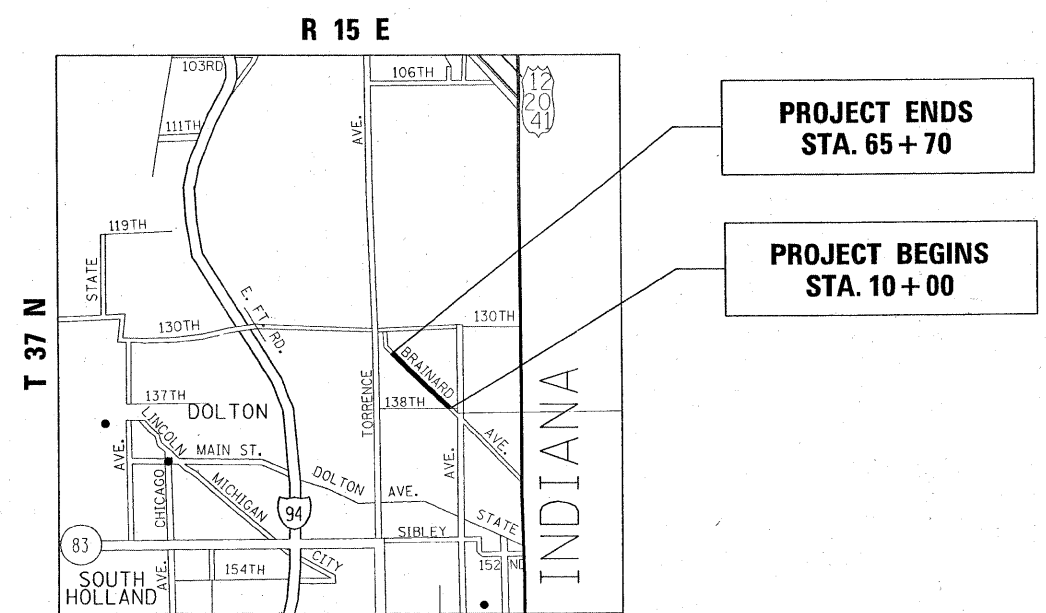

**GROSS AND NET LENGTH OF PROJECT = 5,570 LIN. FT. = 1.05 MILES**

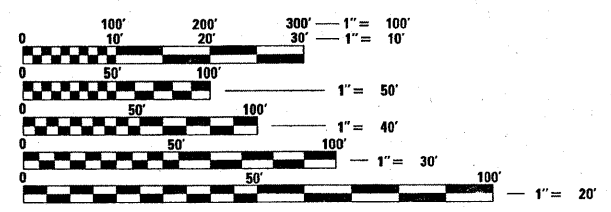

FULL SIZE PLANS HAVE BEEN PREPARED USING STANDARD ENGINEERING SCALES. REDUCED SIZED PLANS WILL NOT CONFORM TO STANDARD SCALES. IN MAKING MEASUREMENTS ON REDUCED PLANS, THE ABOVE SCALES MAY BE USED.

J.U.L.I.E.  
JOINT UTILITY LOCATION INFORMATION FOR EXCAVATION  
1-800-892-0123  
OR 811

**PROJECT ENGINEER: DANIEL WILGREEN (847) 705-4240  
PROJECT MANAGER: KEN ENG (847) 705-4247**

**CONTRACT NO. 62405**

STATE OF ILLINOIS  
DEPARTMENT OF TRANSPORTATION  
DIVISION OF HIGHWAYS

SUBMITTED MARCH 24, 2009

Diana M. O'Keefe DEPUTY DIRECTOR OF HIGHWAYS, REGION ENGINEER  
May 1, 2009

Charles E. Ingessoll ENGINEER OF DESIGN AND ENVIRONMENT  
May 1, 2009

Christine M. Reed DIRECTOR OF HIGHWAYS, CHIEF ENGINEER

**PRINTED BY THE AUTHORITY  
OF THE STATE OF ILLINOIS**

INDEX OF SHEETS

<u>SHEET NO.</u>	<u>DESCRIPTION</u>
1	COVER SHEET
2	INDEX OF SHEETS, STATE STANDARDS, AND GENERAL NOTES
3	SUMMARY OF QUANTITIES
4	TYPICAL SECTIONS
5-7	ROADWAY AND PAVEMENT MARKING PLANS
8	FRAMES AND LIDS ADJUSTMENT WITH MILLING; AND FRAMES AND LIDS ADJUSTMENT WITHOUT MILLING
9	CITY OF CHICAGO DETAILS FOR P.C. CONC. DRIVEWAY, ALLEY RETURN AND SIDEWALK
10	PAVEMENT PATCHING FOR HMA SURFACED PAVEMENT
11	CURB OR CURB AND GUTTER REMOVAL AND REPLACEMENT
12	BUTT JOINT AND HMA TAPER DETAILS
13	TRAFFIC CONTROL AND PROTECTION FOR SIDEROADS, INTERSECTIONS, AND DRIVEWAYS
14	TYPICAL APPLICATION FOR RAISED REFLECTIVE PAVEMENT MARKERS
15	TRAFFIC CONTROL AND PROTECTION AT TURN BAYS
16	PAVEMENT MARKING LETTERS AND SYMBOLS FOR TRAFFIC STAGING
17	ARTERIAL ROAD INFORMATION SIGN
18-19	CITY OF CHICAGO TYPICAL PAVEMENT MARKING

STATE STANDARDS

000001-05	STANDARD SYMBOLS, ABBREVIATIONS AND PATTERNS
280001-04	CLASS C AND D PATCHES
604001-03	FRAME AND LIDS TYPE 1
604086-02	CONCRETE CURB TYPE B AND COMBINATION CONCRETE CURB AND GUTTER
701301-03	LANE CLOSURE, 2L, 2W, SHORT TIME OPERATIONS
701306-02	LANE CLOSURE, 2L, 2W, SLOW MOVING OPERATION DAY ONLY FOR SPEEDS $\geq$ 45 MPH
701311-03	LANE CLOSURE, 2L 2W, MOVING OPERATIO, DAY ONLY
701606-06	URBAN LANE CLOSURE, MULTILANE 2W WITH MOUNTABLE MEDIAN
701701-06	URBAN LANE CLOSURE, MULTILANE INTERSECTION
701901-01	TRAFFIC CONTROL DEVICES
780001-02	TYPICAL PAVEMENT MARKING FOR RAILROAD CROSSING

CHICAGO NOTES

ALL CATCH BASINS IN THE CITY OF CHICAGO MUST MEET THE DEPARTMENT OF WATER MANAGEMENT SEWER SECTION STANDARD.

SEWER SIZES 525 MM (21") DIAMETER OR SMALLER MUST BE EXTRA STRENGTH VITRIFIED CLAY PIPE C-700 OR DUCTILE IRON PIPE WITH PUSHON OR MECHANICAL JOINTS. SEWER SIZES 600 MM (24") DIAMETER OR LARGER MUST BE REINFORCED CONCRETE PIPE TYPE C-76, CLASS III, WALL "B" WITH "O-RING" JOINTS.

PERMITS FROM THE DEPARTMENT OF WATER MANAGEMENT-SEWER SECTION ARE REQUIRED FOR ALL UNDERGROUND STORM, SANITARY OR COMBINED SEWER SYSTEM CONSTRUCTION, AND FOR ALL WORK INVOLVING ADJUSTMENT OF SEWER STRUCTURES. THE DEPARTMENT OF WATER OF WATER MANAGEMENT-SEWER SECTION PERMIT MUST BE OBTAINED BY A LICENSED SEWER DRAIN LAYER PRIOR TO START OF CONSTRUCTION. THE LICENSED SEWER CONTRACTOR/SUBCONTRACTOR MUST SUBMIT TWO SETS OF PLANS APPROVED BY THE DEPARTMENT OF WATER MANAGEMENT SEWER SECTION FOR THE ISSUE OF THE SEWER PERMIT TO SUITE 400, 333 SOUTH STATE STREET, CHICAGO, IL 60604-3971. INSPECTION WILL BE PROVIDED BY THE DEPARTMENT OF SEWERS.

IF THE SEWER PIPE COVER IS REDUCED TO LESS THAN 1 METER (3 FT), CONCRETE ENCASEMENT OF THE SEWER OR REPLACEMENT OF THE SEWER WITH CLASS 52 DUCTILE IRON PIPE WILL BE REQUIRED.

IN CASE OF DAMAGE TO CITY OF CHICAGO SEWERS, PRIVATE AND PUBLIC DRAINS, SEWER STRUCTURES AND/OR BENCH MONUMENTS, THE CONTRACTOR SHALL IMMEDIATELY CONTACT THE DEPARTMENT OF WATER MANAGEMENT-SEWER SECTION AT (312)747-7892 OR (312)747-7893.

PREFORMED LIDS SHALL BE PLACED ON ALL MANHOLES AND CATCH BASINS.

BENCH MONUMENT LOCATIONS WITHIN THE LIMITS OF THE IMPROVEMENT CAN BE OBTAINED FROM THE DEPARTMENT OF WATER MANAGEMENT SEWER SECTION AT SUITE 400, 333 SOUTH STATE STREET, CHICAGO, IL 60604-3971. THE CONTRACTOR IS RESPONSIBLE FOR THE COST OF REPLACING ANY BENCH MONUMET DAMAGE OR DESTROYED DURING CONSTRUCTION.

SIDEWALK ACCESSIBILITY RAMPS SHALL NOT BE CONSTRUCTED DIRECTLY OVER EXISTING OR PROPOSED DRAINAGE STRUCTURES

ALL BROKEN, CRACKED, WORN OR OTHERWISE DAMAGED OR BICYCLE UNSAFE FRAMES AND GRATES OR LIDS ON THE SEWER STRUCTURES SHALL BE REPLACED WITH THE NEW DEPARTMENT OF SEWERS' STANDARD FRAMES AND GRATES OR LIDS. OLD FRAMES AND GRATES OR LIDS SHALL BE DELIVERED TO THE DEPARTMENT OF WATER MANAGEMENT-SEWER SECTION AT 39TH STREET AND ASHLAND AVENUE.

CITY OF CHICAGO WATER VALVE VAULTS AND SEWER STRUCTURES SHALL NOT BE CLOSED, COVERED OR OTHERWISE OBSTRUCTED DURING CONSTRUCTION WITHOUT WRITTEN PERMISSION FROM THE CITY OF CHICAGO DEPARTMENT OF WATER AND/OR DEPARTMENT OF WATER MANAGEMENT SEWER SECTION.

CURB AND GUTTER CONSTRUCTION SHALL PROVIDE A MAXIMUM CURB HEIGHT OF 9" (225 MM) AT DRAINAGE STRUCTURES AND A MINIMUM 3" (75 MM) AT HIGH POINTS.

PAVEMENT REPLACEMENT AROUND FRAMES AND GRATES OR LIDS WHERE DRAINAGE, WATER MAIN OR ELECTRICAL STRUCTURES ARE ADJUSTED OR RECONSTRUCTED, SHALL WITH CLASS SI CONCRETE.

THE CONTRACTOR MUST NOTIFY CHICAGO'S OFFICE OF EMERGENCY MANAGEMENT AND COMMUNICATION (OEMC) 48 HOURS BEFORE COMMENCING CONSTRUCTION OR CHANGING TRAFFIC FLOW.

GENERAL NOTES

BEFORE STARTING ANY EXCAVATION, THE CONTRACTOR SHALL CALL "JULIE" AT 800-892-0123 FOR FIELD LOCATIONS OF BURIED ELECTRIC, TELEPHONE AND GAS FACILITIES. (48 HOURS NOTIFICATION REQUIRED).

10 FEET (3 METER) TRANSITIONS SHALL BE USED TO MATCH PROPOSED CURB AND GUTTER AND MEDIAN ITEMS OF WORK TO EXISTING CURB AND GUTTERS AND MEDIANS IN THE FIELD, UNLESS OTHERWISE SHOWN. THE TRANSITIONS SHALL BE PAID FOR AT THE CONTRACT UNIT PRICE FOR THE PROPOSED ITEMS OF WORK SPECIFIED.

THE CONTRACTOR SHALL COORDINATE CONSTRUCTION ACTIVITIES WITH UTILITY COMPANIES AND THE CITY OF CHICAGO.

THE CONTRACTOR WILL NOT BE ALLOWED TO SET UP A YARD OR FIELD OFFICE ON STATE PROPERTY WITHOUT WRITTEN PERMISSION FROM THE DEPARTMENT.

WHEN MILLED PAVEMENT IS OPEN TO TRAFFIC, THE MAXIMUM GRADE DIFFERENTIAL BETWEEN PASSES OF THE MILLING MACHINE SHALL NOT EXCEED 1 1/2 INCHES (40 MM) WHERE THE SPEED LIMIT IS 45 MPH (80 KM/H) OR LESS AND 1 INCH (25 MM) WHERE THE SPEED LIMIT IS GREATER THAN 45 MPH (80 KM/H). WITH WRITTEN APPROVAL FROM THE ENGINEER, A MAXIMUM GRADE DIFFERENTIAL OF 3 INCHES (75 MM) MAY BE ALLOWED IF THE EDGE OF THE MILLING IS SLOPED A MINIMUM 1:3 (V:H).

BUTT JOINTS WILL BE INSTALLED AT THE ENDS OF ALL RESURFACING (WHERE RESURFACING MEETS EXISTING PAVEMENT), IN ACCORDANCE WITH THE "BUTT JOINT AND HMA TAPER DETAILS" SHEET INCLUDED IN THE PLANS, UNLESS OTHERWISE SPECIFIED.

THE RESIDENT ENGINEER SHALL CONTACT MS. PATRICE HARRIS, AREA TRAFFIC FIELD ENGINEER AT (708) 597-9800 A MINIMUM OF 2 WEEKS PRIOR TO PLACEMENT OF PERMANENT PAVEMENT MARKING.

THE RESIDENT ENGINEER SHALL CONTACT THE TRAFFIC CONTROL SUPERVISOR AT (847) 705-4470 A MINIMUM OF 72 HOURS PRIOR TO THE PLACEMENT OF TEMPORARY TRAFFIC CONTROL DEVICES.

THE RESIDENT ENGINEER SHALL DETERMINE THE LOCATIONS OF CLASS "D" PATCHES.

FILE NAME =	USER NAME = shiranisb	DESIGNED -	REVISED -	<b>STATE OF ILLINOIS DEPARTMENT OF TRANSPORTATION</b>	<b>INDEX OF SHEETS, STATE STANDARDS, AND GENERAL NOTES BRAINARD AVE. SO 130TH ST. TO NO BURNHAM AVE.</b>	F.A.U. RTE.	SECTION	COUNTY	TOTAL SHEETS	SHEET NO.	
ca:\pw\work\PWIDOT\SHIRANISB\dms98877\sh	rdmg.dgn	DRAWN -	REVISED -			3592	(0701, 0707.1 & 0708) RS-11	COOK	19	2	
	PLOT SCALE = 50.0000' / IN.	CHECKED -	REVISED -			CONTRACT NO. 62405					
	PLOT DATE = 3/11/2009	DATE -	REVISED -			SCALE: 1"=50'	SHEET NO. OF SHEETS	STA. TO STA.	FED. ROAD DIST. NO. 1 ILLINOIS FED. AID PROJECT		

SUMMARY OF QUANTITIES			100% STATE	CONSTRUCTION TYPE CODE					SUMMARY OF QUANTITIES			100% STATE	CONSTRUCTION TYPE CODE				
CODE NO	ITEM	UNIT	TOTAL QUANTITIES	URBAN 1000					CODE NO	ITEM	UNIT	TOTAL QUANTITIES	URBAN 1000				
20201006	GRADING AND SHAPING SHOULDERS	UNIT	2	2					70300240	TEMPORARY PAVEMENT MARKING - LINE 6"	FOOT	950	950				
40600200	BITUMINOUS MATERIALS (PRIME COAT)	TON	12	12					70300280	TEMPORARY PAVEMENT MARKING - LINE 24"	FOOT	230	230				
40600300	AGGREGATE (PRIME COAT)	TON	59	59					70301000	WORK ZONE PAVEMENT MARKING REMOVAL	SQ FT	400	400				
40600400	MIXTURE FOR CRACKS, JOINTS, AND FLANGEWAYS	TON	9	9					* 78000100	THERMOPLASTIC PAVEMENT MARKING - LETTERS AND SYMBOLS	SQ FT	123	123				
40600895	CONSTRUCTING TEST STRIP	EACH	2	2					* 78000200	THERMOPLASTIC PAVEMENT MARKING - LINE 4"	FOOT	10056	10056				
40600982	HOT-MIX ASPHALT SURFACE REMOVAL - BUTT JOINT	SQ YD	316	316					* 78000400	THERMOPLASTIC PAVEMENT MARKING - LINE 6"	FOOT	950	950				
40601005	HOT-MIX ASPHALT REPLACEMENT OVER PATCHES	TON	977	977					* 78000650	THERMOPLASTIC PAVEMENT MARKING - LINE 24"	FOOT	230	230				
40603340	HOT-MIX ASPHALT SURFACE COURSE, MIX "D", N70	TON	2540	2540					78100100	RAISED REFLECTIVE PAVEMENT MARKER	EACH	270	270				
42001300	PROTECTIVE COAT	SQ YD	556	556					X0322256	TEMPORARY INFORMATION SIGNING	SQ FT	51.4	51.4				
42400200	PORTLAND CEMENT CONCRETE SIDEWALK 5 INCH	SQ FT	1000	1000					X0656100	DRIVEWAY PAVEMENT REMOVAL AND REPLACEMENT	SQ YD	50	50				
44000158	HOT-MIX ASPHALT SURFACE REMOVAL, 2 1/4"	SQ YD	29325	29,325					X4067107	POLYMERIZED LEVELING BINDER (MACHINE METHOD), IL-4.75, N50	TON	1190	1190				
44000600	SIDEWALK REMOVAL	SQ FT	1000	1000					Z0018500	DRAINAGE STRUCTURES TO BE CLEANED	EACH	10	10				
44001700	COMBINATION CONCRETE CURB AND GUTTER REMOVAL AND REPLACEMENT	FOOT	2500	2500					Z0048665	RAILROAD PROTECTIVE LIABILITY INSURANCE	L SUM	1	1				
44002216	HOT-MIX ASPHALT REMOVAL OVER PATCHES, 4"	SQ YD	4362	4362													
44201753	CLASS D PATCHES, TYPE II, 9 INCH	SQ YD	1730	1730													
44201757	CLASS D PATCHES, TYPE III, 9 INCH	SQ YD	720	720													
44201759	CLASS D PATCHES, TYPE IV, 9 INCH	SQ YD	1880	1880													
48102100	AGGREGATE WEDGE SHOULDER, TYPE B	TON	8	8													
60300105	FRAMES AND GRATES TO BE ADJUSTED	EACH	26	26													
60300310	FRAMES AND LIDS TO BE ADJUSTED (SPECIAL)	EACH	49	49													
60400105	FRAMES, TYPE 1	EACH	19	19													
67000400	ENGINEER'S FIELD OFFICE, TYPE A	CAL MO	6	6													
67100100	MOBILIZATION	L SUM	1	1													
70100460	TRAFFIC CONTROL AND PROTECTION, STANDARD 701306	L SUM	1	1													
70102625	TRAFFIC CONTROL AND PROTECTION, STANDARD 701606	L SUM	1	1													
70102635	TRAFFIC CONTROL AND PROTECTION, STANDARD 701701	L SUM	1	1													
70300100	SHORT-TERM PAVEMENT MARKING	FOOT	3530	3530													
70300210	TEMPORARY PAVEMENT MARKING - LETTERS AND SYMBOLS	SQ FT	123	123													
70300220	TEMPORARY PAVEMENT MARKING - LINE 4"	FOOT	10056	10056													

\* Specialty Items

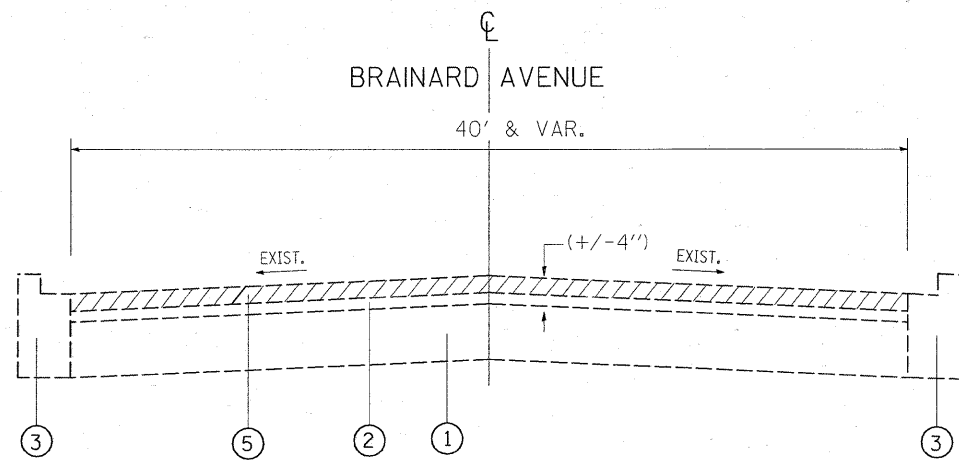

EXISTING TYPICAL SECTION

STA 10+00 TO STA 15+50  
 STA 48+78 TO STA 65+70  
 \* SEE DETAIL A

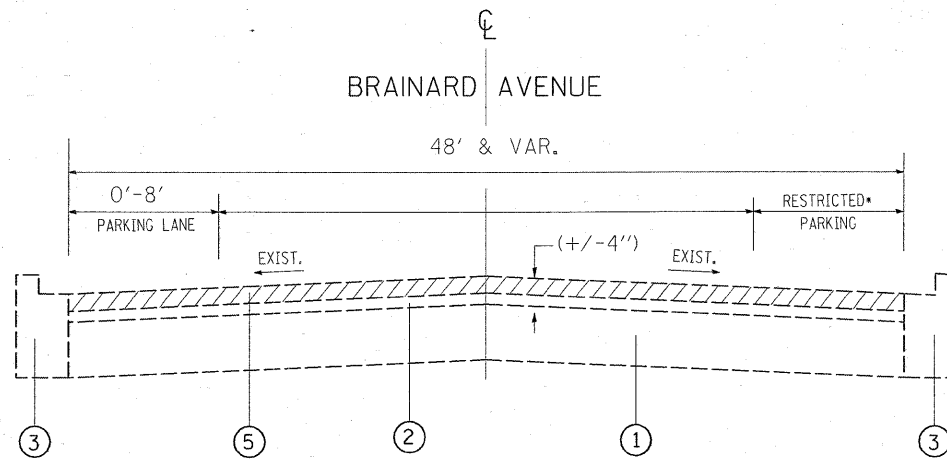

EXISTING TYPICAL SECTION

STA 15+50 TO STA 48+78

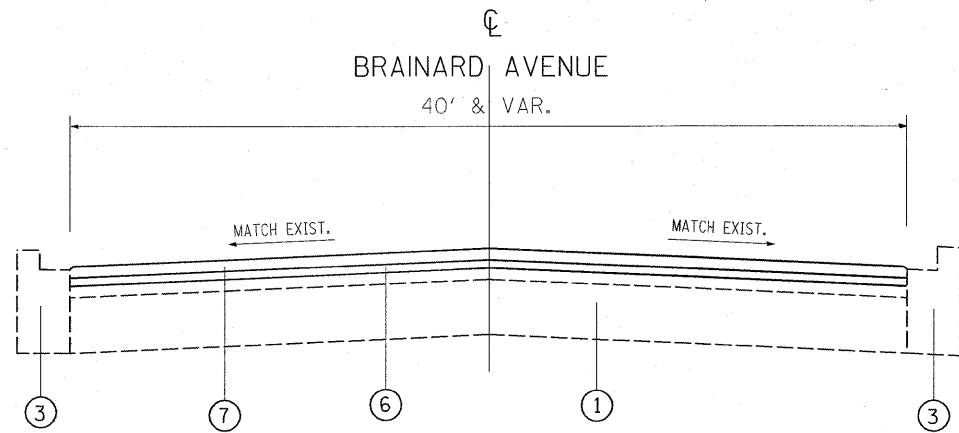

PROPOSED TYPICAL SECTION

STA 10+00 TO STA 15+50  
 STA 48+78 TO STA 65+70  
 \* SEE DETAIL A

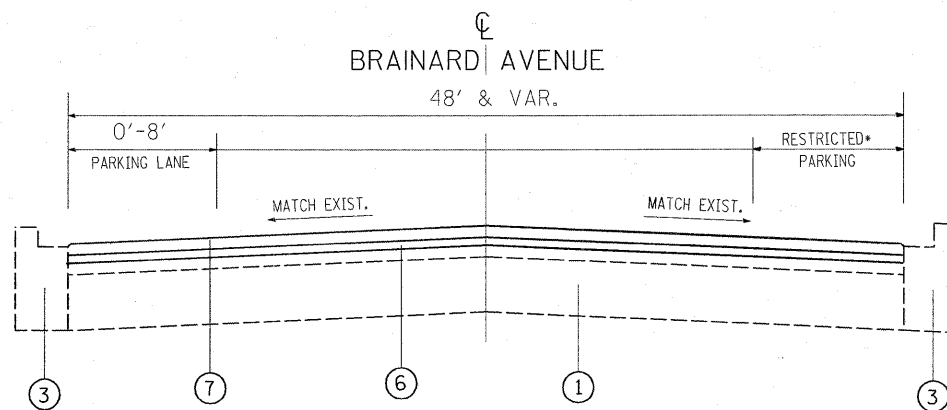

PROPOSED TYPICAL SECTION

STA 15+50 TO STA 48+78

LEGEND

- ① EXISTING P.C.C. PAVEMENT, 9" (+/-)
- ② EXISTING HMA SURFACE COURSE, 4" (+/-)
- ③ EXISTING COMBINATION CONCRETE CURB AND GUTTER
- ④ EXISTING AGGREGATE SHOULDER
- ⑤ PROPOSED HMA SURFACE REMOVAL, 2 1/4 "
- ⑥ PROPOSED POLYMERIZED LEVELING BINDER (MACHINE METHOD), IL-4.75, N50, 3/4 "
- ⑦ PROPOSED HMA SURFACE COURSE, MIX "D", N70, 1 1/2 "
- ⑧ PROPOSED AGGREGATE SHOULDER

\* CONTRACTOR SHALL PATCH FIRST BEFORE MILLING

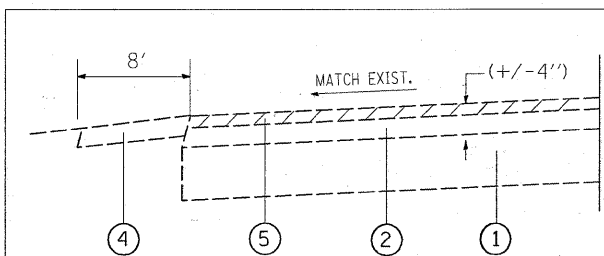

STA. 10+00 TO STA. 12+37  
 DETAIL A

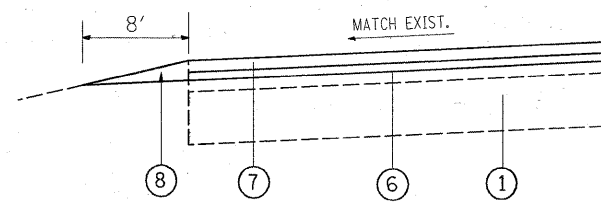

STA. 10+00 TO STA. 12+37  
 DETAIL A

HOT-MIX ASPHALT MIXTURE REQUIREMENTS		
MIXTURE USES	AC TYPE	DESIGN AIR VOIDS
HMA SURFACE COURSE, MIX "D", N70 (IL-9.5 mm)	PG 64-22	4% AT 70 GYR.
POLYMERIZED LEVELING BINDER (MM), IL-4.75, N50	SBS/SBR PG 76-28/-22	4% AT 50 GYR.
HMA REPLACEMENT OVER PATCHES (HMA BINDER, IL-19.0 mm)	* PG 64-22	4% AT 70 GYR.
CLASS D PATCHES, (HMA BINDER IL-19.0 mm)	* PG 64-22	4% AT 70 GYR.

NOTES:

THE UNIT WEIGHT USED TO CALCULATE ALL HMA SURFACE COURSE MIXTURES IS 112 LBS/SY/IN  
 \* WHEN RAP EXCEEDS 20%, THE NEW ASPHALT BINDER IN THE MIX SHALL BE PG 58-22

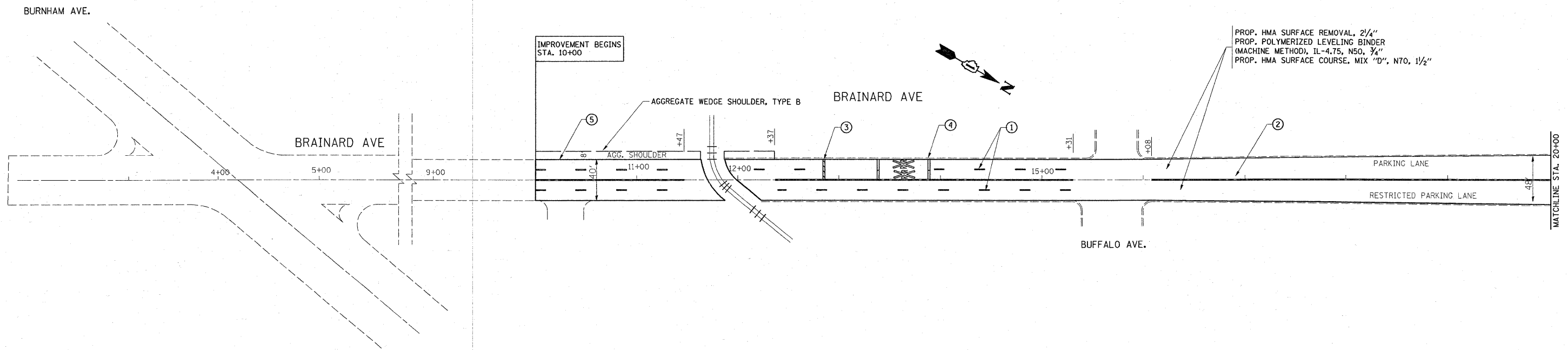

**LEGEND:**

- ① PROPOSED THERMOPLASTIC PAVEMENT MARKING LINE 4", SKIP DASH @ 30' SKIP AND 10' DASH, WHITE (TYP.)
- ② PROPOSED THERMOPLASTIC PAVEMENT MARKING LINE 4", DOUBLE LINE @ 11" C-C, YELLOW (TYP.)
- ③ PROPOSED THERMOPLASTIC PAVEMENT MARKING LINE 24", STOP BAR, WHITE (TYP.)
- ④ PROPOSED THERMOPLASTIC PAVEMENT MARKING LINE 24", TRANSVERSE LINES, RAILROAD CROSSING, WHITE (TYP.)
- ⑤ PROPOSED THERMOPLASTIC PAVEMENT MARKING LINE 4", EDGE LINE, WHITE (TYP.)
- ⑥ PROPOSED THERMOPLASTIC PAVEMENT MARKING LINE 6", CROSSWALK (PEDESTRIAN), WHITE (TYP.)

**NOTE:**

LIMIT OF RESURFACING ON SIDE ROADS AND STREETS SHALL BE TO THE RADIUS OF RETURN OR AS DIRECTED BY THE ENGINEER.

ALL PERMANENT PAVEMENT MARKINGS SHALL BE THERMOPLASTIC UNLESS OTHERWISE NOTED. SEE "DISTRICT ONE TYPICAL PAVEMENT MARKINGS" DETAIL (TC-13).

RAISED REFLECTIVE PAVEMENT MARKERS SHALL BE USED THROUGH THE IMPROVEMENT LIMITS. SEE "DISTRICT ONE TYPICAL APPLICATIONS RAISED REFLECTIVE PAVEMENT MARKERS" DETAIL (TC-11).

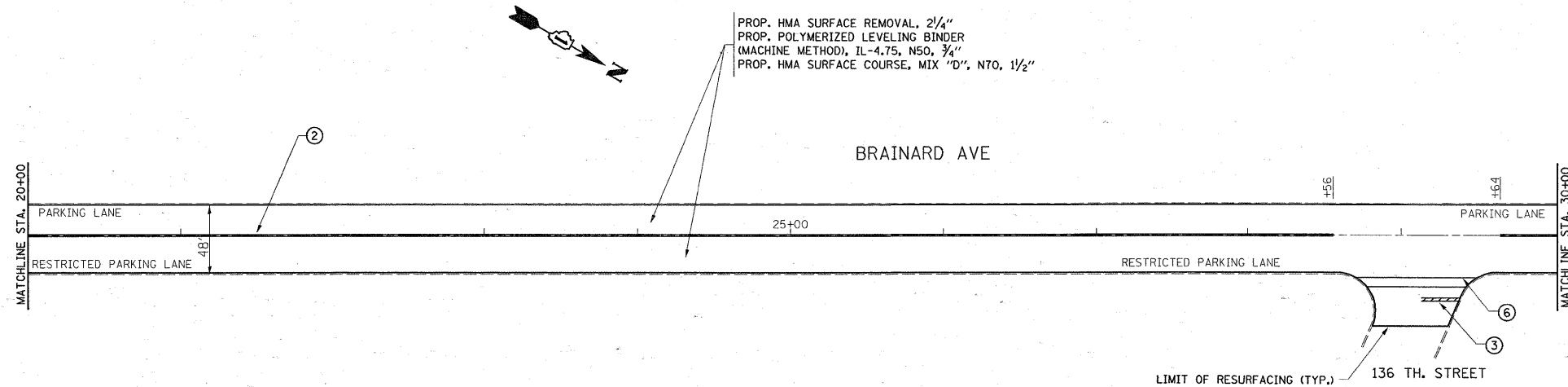

FILE NAME =	USER NAME = shiranisb	DESIGNED -	REVISED -
c:\pw_work\PWIDOT\SHIRANISB\dms88877\sh	shiranisb.dgn	DRAWN -	REVISED -
	PLOT SCALE = 50.0000' / IN.	CHECKED -	REVISED -
	PLOT DATE = 3/11/2009	DATE -	REVISED -

**STATE OF ILLINOIS  
DEPARTMENT OF TRANSPORTATION**

**ROADWAY AND PAVEMENT MARKING PLANS  
BRAINARD AVE. S.O 130TH ST. TO NO BURNHAM AVE.**

SCALE: 1"=50' SHEET NO. OF SHEETS STA. TO STA.

F.A.J. RTE.	SECTION	COUNTY	TOTAL SHEETS	SHEET NO.
3592	(0701, 0707.1 & 0708) RS-11	COOK	19	5
CONTRACT NO. 62405			FED. ROAD DIST. NO. 1 ILLINOIS FED. AID PROJECT	

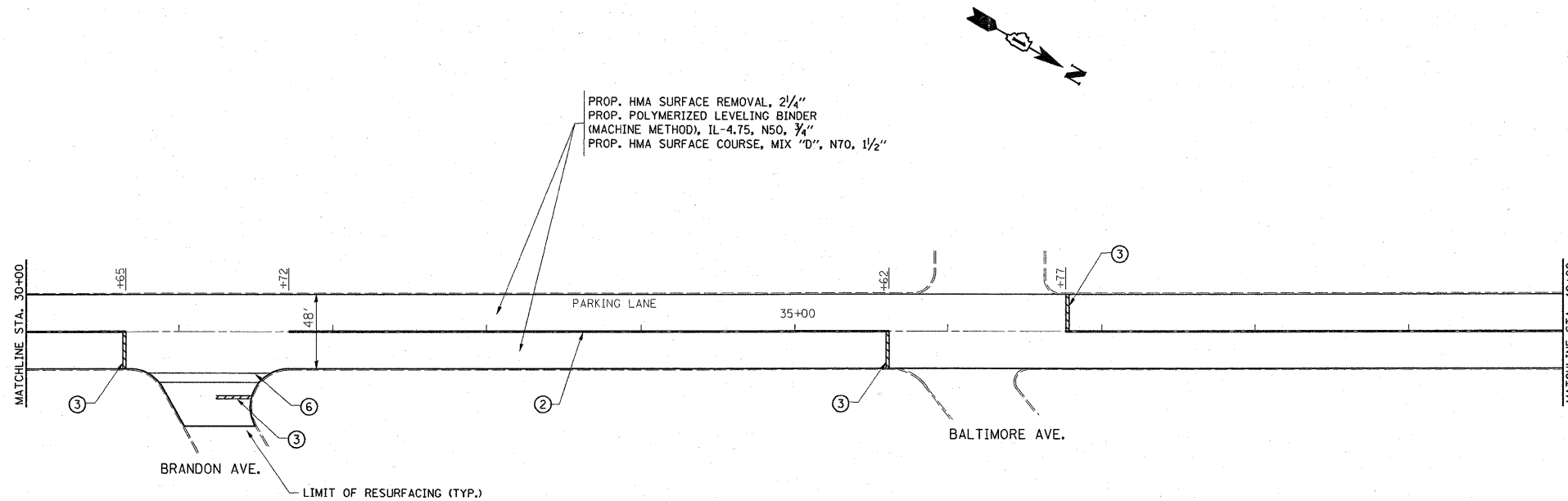

**LEGEND:**

- ① PROPOSED THERMOPLASTIC PAVEMENT MARKING LINE 4", SKIP DASH @ 30' SKIP AND 10' DASH, WHITE (TYP.)
- ② PROPOSED THERMOPLASTIC PAVEMENT MARKING LINE 4", DOUBLE LINE @ 11" C-C, YELLOW (TYP.)
- ③ PROPOSED THERMOPLASTIC PAVEMENT MARKING LINE 24", STOP BAR, WHITE (TYP.)
- ④ PROPOSED THERMOPLASTIC PAVEMENT MARKING LINE 24", TRANSVERSE LINES, RAILROAD CROSSING, WHITE (TYP.)
- ⑤ PROPOSED THERMOPLASTIC PAVEMENT MARKING LINE 4", EDGE LINE, WHITE (TYP.)
- ⑥ PROPOSED THERMOPLASTIC PAVEMENT MARKING LINE 6", CROSSWALK (PEDESTRIAN), WHITE (TYP.)

**NOTE:**

LIMIT OF RESURFACING ON SIDE ROADS AND STREETS SHALL BE TO THE RADIUS OF RETURN OR AS DIRECTED BY THE ENGINEER.

ALL PERMANENT PAVEMENT MARKINGS SHALL BE THERMOPLASTIC UNLESS OTHERWISE NOTED. SEE "DISTRICT ONE TYPICAL PAVEMENT MARKINGS" DETAIL (TC-13).

RAISED REFLECTIVE PAVEMENT MARKERS SHALL BE USED THROUGH THE IMPROVEMENT LIMITS. SEE "DISTRICT ONE TYPICAL APPLICATIONS RAISED REFLECTIVE PAVEMENT MARKERS" DETAIL (TC-11).

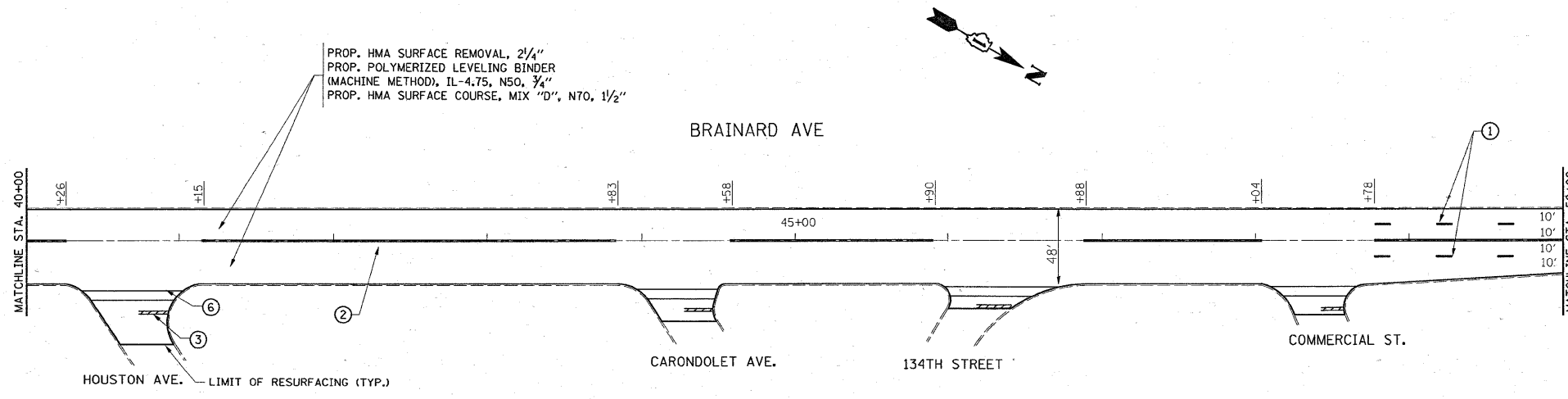

FILE NAME =	USER NAME = shiranisb	DESIGNED -	REVISED -	<b>STATE OF ILLINOIS DEPARTMENT OF TRANSPORTATION</b>	<b>ROADWAY AND PAVEMENT MARKING PLANS BRAINARD AVE. SO 130TH ST. TO NO BURNHAM AVE.</b>	F.A.I. RTE.	SECTION	COUNTY	TOTAL SHEETS	SHEET NO.
c:\pw_work\PW\DOT\SHIRANISB\dms88877\sh...	DRAWN -	REVISED -	3592			(0701, 0707.1 & 0708) RS-11	COOK	19	6	
PLOT SCALE = 50.0000 / IN.	CHECKED -	REVISED -	CONTRACT NO. 62405							
PLOT DATE = 3/11/2009	DATE -	REVISED -	FED. ROAD DIST. NO. 1 [ILLINOIS] FED. AID PROJECT							
				SCALE: 1"=50'	SHEET NO. OF SHEETS	STA. TO STA.				

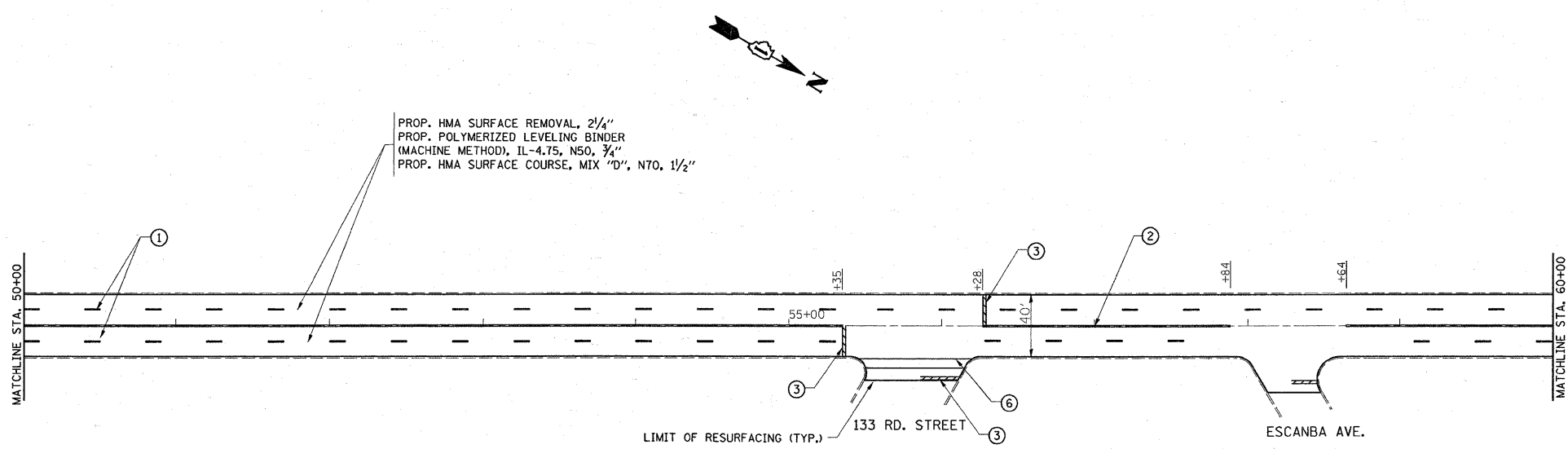

PROP. HMA SURFACE REMOVAL, 2/4"  
 PROP. POLYMERIZED LEVELING BINDER  
 (MACHINE METHOD), IL-4.75, N50, 3/4"  
 PROP. HMA SURFACE COURSE, MIX "D", N70, 1/2"

**LEGEND:**

- ① PROPOSED THERMOPLASTIC PAVEMENT MARKING LINE 4", SKIP DASH @ 30' SKIP AND 10' DASH, WHITE (TYP.)
- ② PROPOSED THERMOPLASTIC PAVEMENT MARKING LINE 4", DOUBLE LINE @ 11" C-C, YELLOW (TYP.)
- ③ PROPOSED THERMOPLASTIC PAVEMENT MARKING LINE 24", STOP BAR, WHITE (TYP.)
- ④ PROPOSED THERMOPLASTIC PAVEMENT MARKING LINE 24", TRANSVERSE LINES, RAILROAD CROSSING, WHITE (TYP.)
- ⑤ PROPOSED THERMOPLASTIC PAVEMENT MARKING LINE 4", EDGE LINE, WHITE (TYP.)
- ⑥ PROPOSED THERMOPLASTIC PAVEMENT MARKING LINE 6", CROSSWALK (PEDESTRIAN), WHITE (TYP.)

**NOTE:**

LIMIT OF RESURFACING ON SIDE ROADS AND STREETS SHALL BE TO THE RADIUS OF RETURN OR AS DIRECTED BY THE ENGINEER.

ALL PERMANENT PAVEMENT MARKINGS SHALL BE THERMOPLASTIC UNLESS OTHERWISE NOTED. SEE "DISTRICT ONE TYPICAL PAVEMENT MARKINGS" DETAIL (TC-13).

RAISED REFLECTIVE PAVEMENT MARKERS SHALL BE USED THROUGH THE IMPROVEMENT LIMITS. SEE "DISTRICT ONE TYPICAL APPLICATIONS RAISED REFLECTIVE PAVEMENT MARKERS" DETAIL (TC-11).

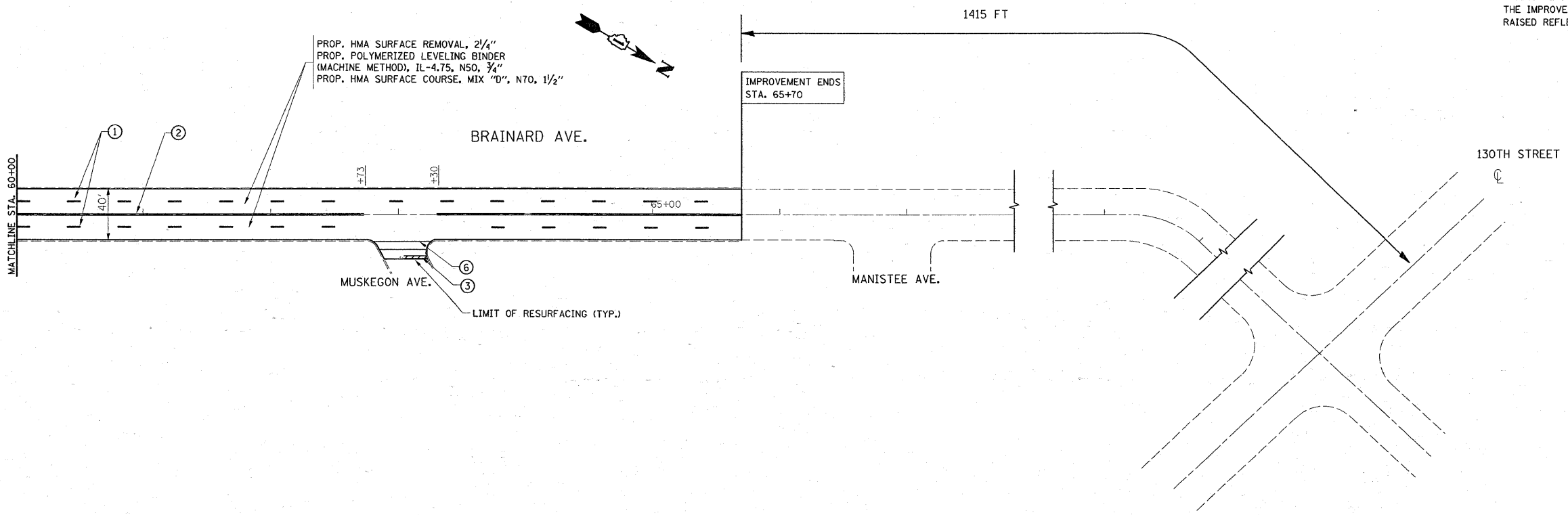

PROP. HMA SURFACE REMOVAL, 2/4"  
 PROP. POLYMERIZED LEVELING BINDER  
 (MACHINE METHOD), IL-4.75, N50, 3/4"  
 PROP. HMA SURFACE COURSE, MIX "D", N70, 1/2"

FILE NAME =	USER NAME = shiranisb	DESIGNED -	REVISED -	<b>STATE OF ILLINOIS DEPARTMENT OF TRANSPORTATION</b>	<b>ROADWAY AND PAVEMENT MARKING PLANS BRAINARD AVE. S/O 130TH ST. TO NO BURNHAM AVE.</b>			F.A.U. RTE.	SECTION	COUNTY	TOTAL SHEETS	SHEET NO.
c:\pwork\pwork\SHIRANISB\dms88877\sh	rdw.dgn	DRAWN -	REVISED -		3592	(0701, 0707.1 & 0708) RS-11	COOK	19	7			
PLOT SCALE = 50.0000' / IN.	CHECKED -	REVISED -	SCALE: 1"=50'		SHEET NO. OF SHEETS		STA. TO STA.		CONTRACT NO. 62405			
PLOT DATE = 3/11/2009	DATE -	REVISED -			FED. ROAD DIST. NO. 1		ILLINOIS FED. AID PROJECT					





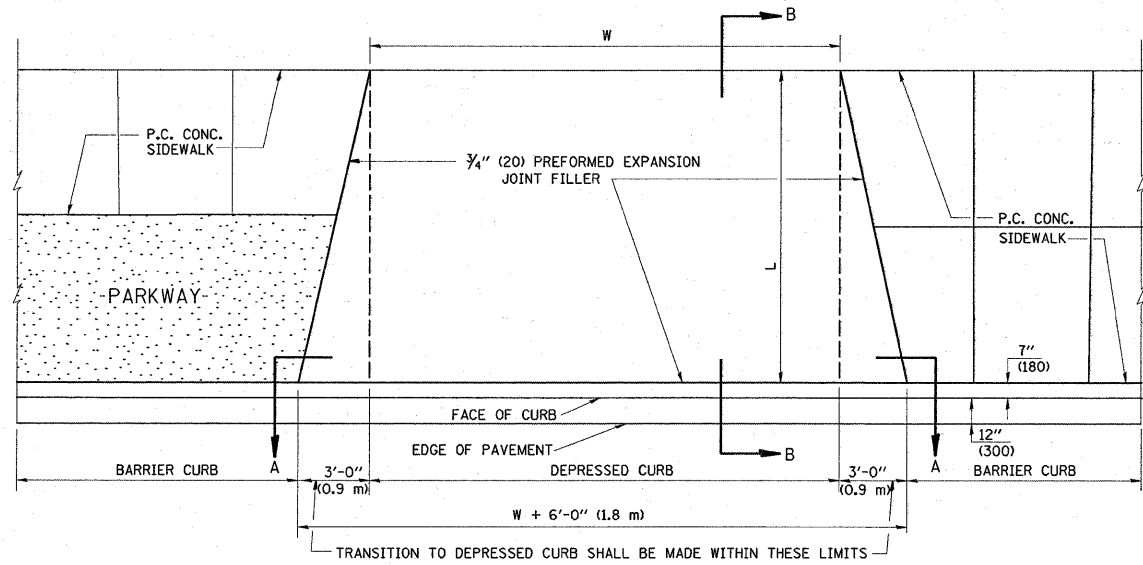

PLAN VIEW

- NOTES:
1. EXPANSION JOINTS SHALL BE CONSTRUCTED AS SHOWN ON THE DETAILS FOR P.C.C. SIDEWALK.
  2. THE CURB BETWEEN ADJACENT DRIVEWAYS SHALL BE FULL HEIGHT FOR A DISTANCE OF AT LEAST FOUR FEET (1.2 METERS)
  3. P.C. CONCRETE DRIVEWAYS SHALL BE CONSTRUCTED AT LOCATIONS SHOWN ON THE PLANS OR AS DIRECTED BY THE ENGINEER.
  4. 3/4" (20) PREFORMED EXPANSION JOINTS WILL NOT BE PAID FOR SEPARATELY BUT SHALL BE CONSIDERED INCIDENTAL TO P.C.C. DRIVEWAY PAVEMENT 8" (200).
  5. COMBINATION CONC. CURB AND GUTTER SHALL BE MEASURED STRAIGHT ACROSS THE DRIVEWAY. NO ADDITIONAL COMPENSATION WILL BE ALLOWED FOR THE TRANSITION CURB AND GUTTER.

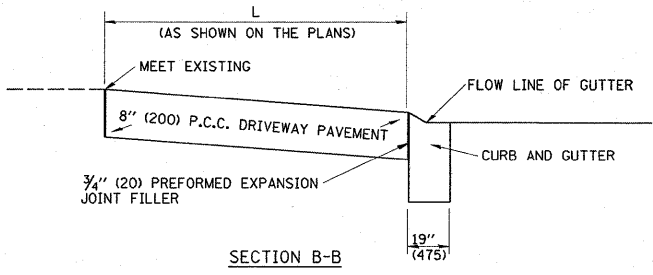

SECTION B-B

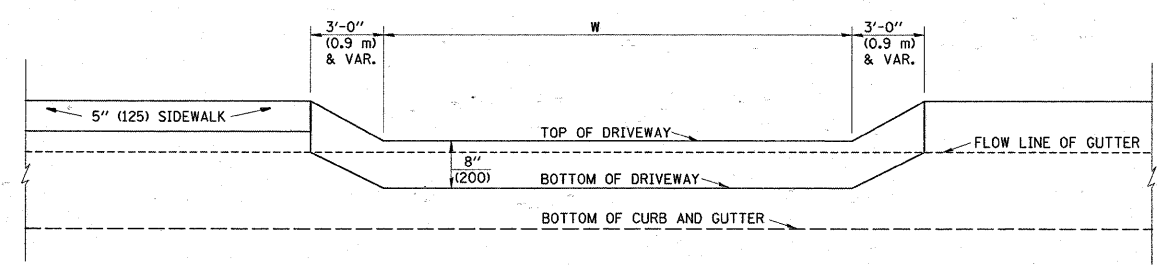

SECTION A-A

P.C.C. DRIVEWAY PAVEMENT DETAIL

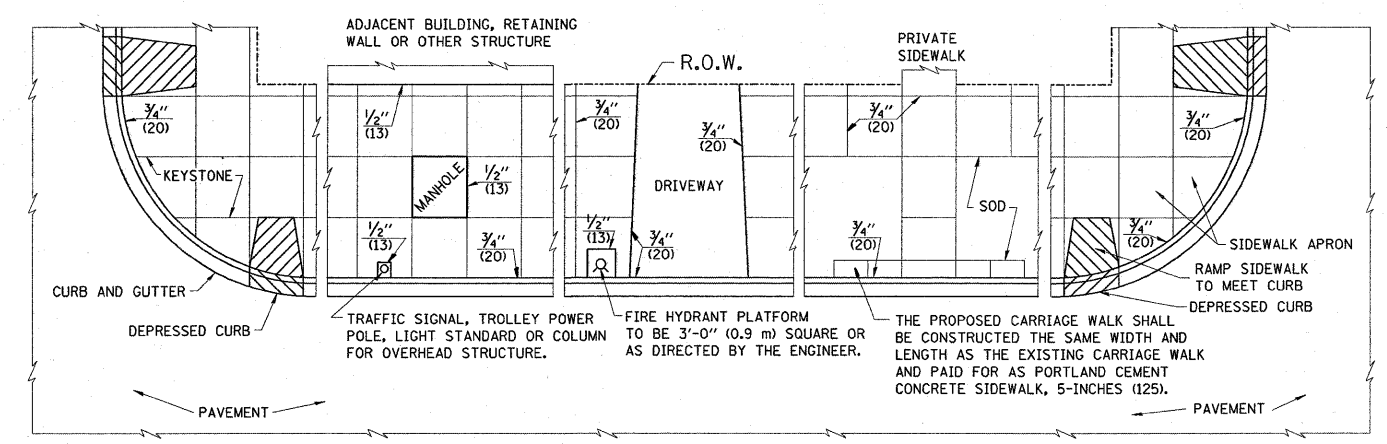

NOTES:

1. ONE-HALF INCH THICK EXPANSION JOINTS SHALL BE PLACED BETWEEN THE SIDEWALK AND ALL STRUCTURES SUCH AS LIGHT STANDARDS, TRAFFIC LIGHT STANDARDS, MANHOLES, WHICH EXTEND THROUGH THE SIDEWALK.
2. 3/4" (20) THICK EXPANSION JOINTS SHALL BE PLACED AT INTERVALS OF NOT MORE THAN 100 FEET (30 METERS) IN THE SIDEWALK. WHERE THE SIDEWALK IS CONSTRUCTED ADJACENT TO PAVEMENT OR CURB HAVING EXPANSION JOINTS, THE EXPANSION JOINTS IN THE SIDEWALK SHALL BE PLACED OPPOSITE THE EXISTING EXPANSION JOINTS AS NEARLY AS PRACTICABLE. EXPANSION JOINTS SHALL ALSO BE PLACED WHERE THE SIDEWALK ABUTS EXISTING SIDEWALKS, BETWEEN DRIVEWAY PAVEMENT AND SIDEWALK, AND BETWEEN SIDEWALK AND CURBS WHERE THE SIDEWALK ABUTS A CURB.

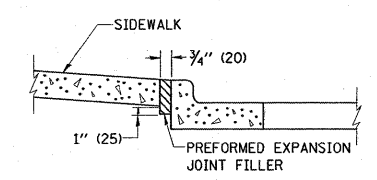

SLOPE FOR SIDEWALK  
1" (25) IN 3'-0" (0.9 m) IN CHICAGO

PORTLAND CEMENT CONCRETE SIDEWALK DETAILS

NOTES: NO EXTRA COMPENSATION SHALL BE ALLOWED FOR THE GUTTER FLARE

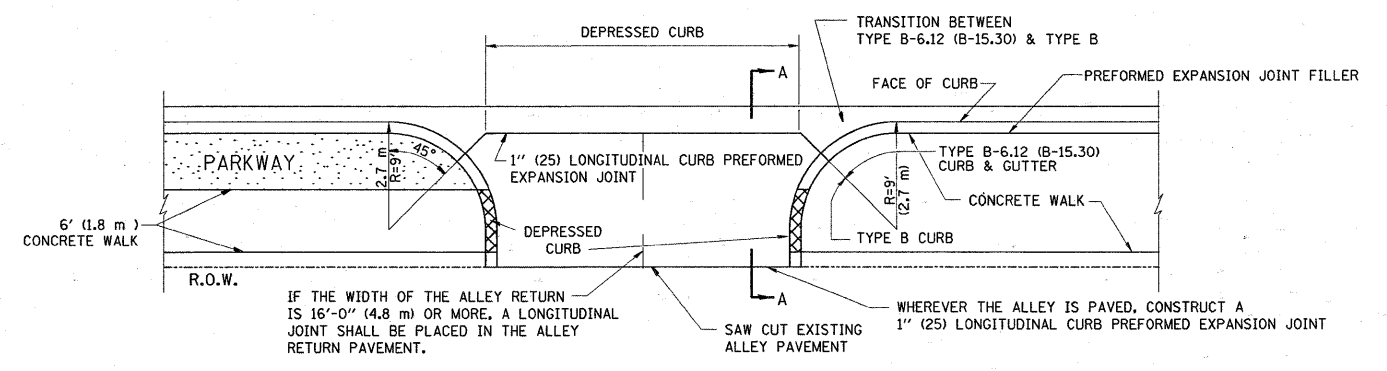

SECTION A-A

ALLEY RETURN DETAIL

ALL DIMENSIONS ARE IN INCHES (MILLIMETERS) UNLESS OTHERWISE SHOWN

FILE NAME = P:\Dtail-Brainerd\1\bd17.dgn	USER NAME = shronisb	DESIGNED - M. DE YONG	REVISED -	<b>STATE OF ILLINOIS DEPARTMENT OF TRANSPORTATION</b>	<b>CITY OF CHICAGO DETAILS FOR P.C. CONCRETE DRIVEWAY, ALLEY RETURN AND SIDEWALK</b>	F.A.U. RTE. 3592	SECTION (0707, 0707.1 & 0708)	COUNTY COOK	TOTAL SHEETS 19	SHEET NO. 9		
PLDT SCALE = 49.9999 1/1 IN.	CHECKED -	DATE - 06-13-90	REVISED -			SCALE: NONE	SHEET NO. 1 OF 1 SHEETS	STA. TO STA.	FED. ROAD DIST. NO. 1 [ILLINOIS] FED. AID PROJECT			
PLDT DATE = 3/7/2009	DATE -	REVISED -	REVISED -			CONTRACT NO. 62405						

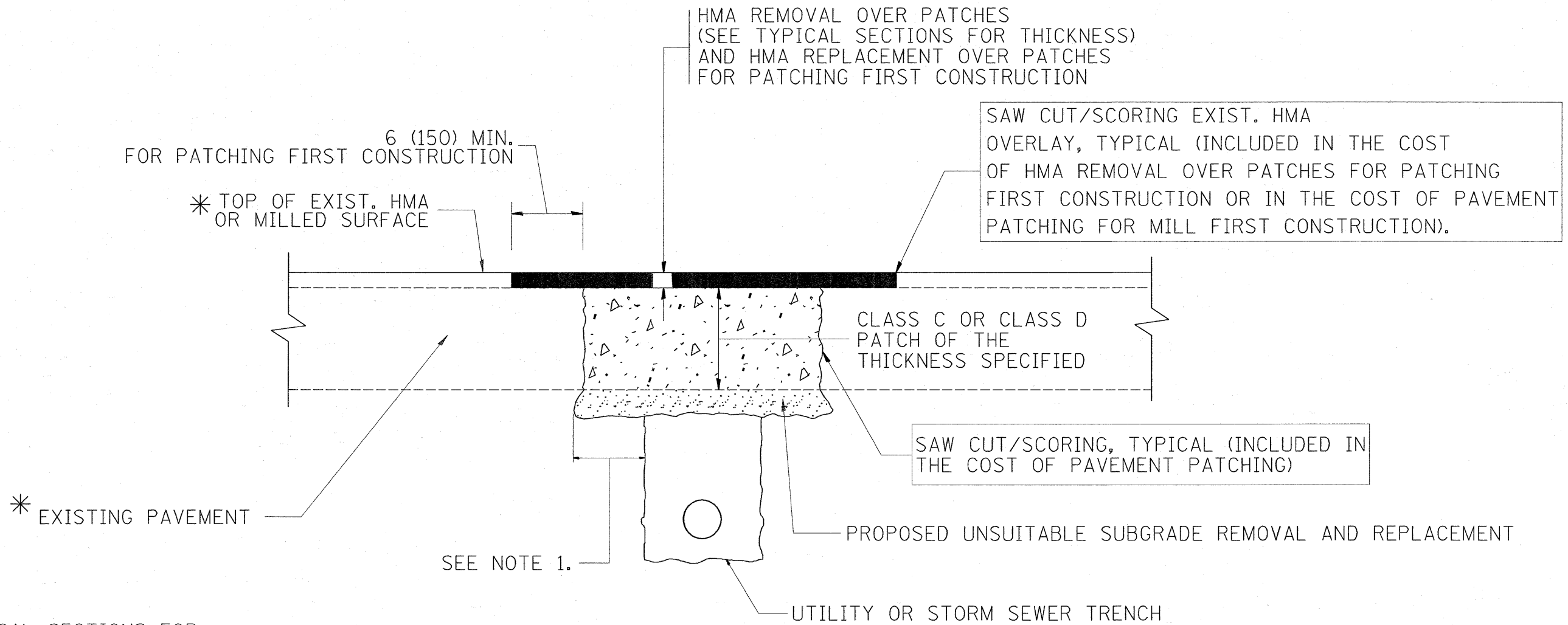

\* SEE TYPICAL SECTIONS FOR THICKNESS AND MATERIALS

**NOTES:**

1. THE WIDTH OF THE FULL DEPTH PATCH OVER A TRENCH SHALL BE 12 (300) WIDER ON EACH SIDE OF THE TRENCH.
2. FOR METHOD OF MEASUREMENT AND BASIS OF PAYMENT, SEE RECURRING SPECIAL PROVISION "PATCHING WITH HOT-MIX ASPHALT OVERLAY REMOVAL".

SEQUENCE OF CONSTRUCTION (PATCHING FIRST)

1. REMOVE THE EXISTING HMA MATERIAL OVER THE AREA TO BE PATCHED.
2. REMOVE AND REPLACE WITH CLASS C OR D PATCH.
3. REPLACE HMA MATERIAL OVER THE AREA TO BE PATCHED.

SEQUENCE OF CONSTRUCTION (MILLING FIRST)

1. MILL HMA FIRST IF THERE IS AT LEAST 4 1/2 INCHES OR MORE OF HMA MATERIAL ON TOP OF THE EXISTING PAVEMENT OR IF THE PAVEMENT IS FULL DEPTH HMA. A MINIMUM OF 2 INCHES OF HMA MATERIAL SHALL BE IN PLACE AFTER MILLING.
2. REMOVE AND REPLACE WITH FULL DEPTH CLASS D PATCHES TO TOP OF MILLED SURFACE.

ALL DIMENSIONS ARE IN INCHES (MILLIMETERS) UNLESS OTHERWISE SHOWN.

FILE NAME = P:\Dtail-Brainard1\bd22.dgn	USER NAME = shiraniqb	DESIGNED - R. SHAH	REVISED - A. ABBAS 04-27-98	<b>STATE OF ILLINOIS DEPARTMENT OF TRANSPORTATION</b>	<b>PAVEMENT PATCHING FOR HMA SURFACED PAVEMENT</b>			F.A.U. RTE. 3592	SECTION (0707, 0707.1 & 0708)	COUNTY COOK	TOTAL SHEETS 19	SHEET NO. 10
	PLOT SCALE = 50,000' / IN.	DRAWN -	REVISED - R. BORO 01-01-07		SCALE: NONE	SHEET NO. 1 OF 1 SHEETS	STA. TO STA.	<b>BD400-04 (BD-22)</b>		CONTRACT NO. 62405		
	PLOT DATE = 3/7/2009	CHECKED -	REVISED - R. BORO 09-04-07									
		DATE - 10-25-94	REVISED - K. ENG 10-27-08									

VARIABLE - TO MEET EXISTING DIMENSIONS AND FIELD CONDITIONS (SEE NOTE ②)

PROP. CONC. CURB OR CURB AND GUTTER REPLACEMENT IN ACCORDANCE WITH STATE STANDARD 606001. (SEE NOTE ②)

SAW CUT FULL DEPTH - INCLUDED IN THE COST OF SIDEWALK, DRIVEWAY OR MEDIAN SURFACE REMOVAL PAY ITEM.

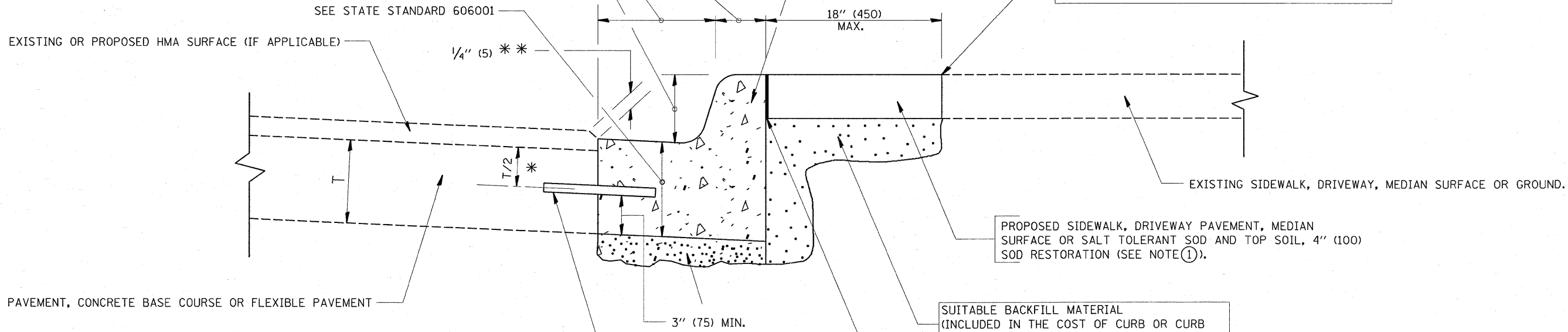

\* 3" (75) MINIMUM FROM TOP AND BOTTOM OF THE CONCRETE PAVEMENT OR BASE COURSE.

\*\* IF THE FINAL SURFACE OF THE PAVEMENT IS CONCRETE, THE GUTTER IS TO BE FLUSH WITH THE PAVEMENT.

NOTE: ① SIDEWALK, DRIVEWAY PAVEMENT OR MEDIAN SURFACE SHALL BE SIMILAR TO THE MATERIAL BEING REMOVED AND WILL BE PAID FOR SEPARATELY.

SALT TOLERANT SOD AND TOP SOIL, 4" (100) RESTORATION WILL NOT BE PAID FOR SEPARATELY, BUT SHALL BE INCLUDED IN THE COST OF CURB OR CURB AND GUTTER REMOVAL AND REPLACEMENT.

② CURB OR CURB AND GUTTER REPLACEMENT SHALL MATCH THE SHAPE OF THE EXISTING CURB OR CURB AND GUTTER UNLESS OTHERWISE SPECIFIED.

③ FOR CURB OR CURB AND GUTTER REMOVAL AND REPLACEMENT ADJACENT TO FLEXIBLE PAVEMENT DELETE EPOXY COATED TIE BARS.

④ LONGITUDINAL BARS, IF ENCOUNTERED IN THE EXISTING CURB OR CURB AND GUTTER, ARE NOT TO BE REPLACED. CUTTING AND REMOVING LONGITUDINAL BARS SHALL BE INCLUDED IN THE COST OF CURB OR CURB AND GUTTER REMOVAL AND REPLACEMENT.

⑤ THE COST OF HMA SURFACE REMOVAL IN THE EXISTING GUTTER FLAG SHALL BE INCLUDED IN THE COST OF THE CURB AND GUTTER REMOVAL AND REPLACEMENT.

⑥ THE REMOVAL AND REPLACEMENT OF THE EXISTING CURB OR CURB AND GUTTER SHALL BE DONE IN ACCORDANCE WITH THE APPLICABLE PORTIONS OF SECTION 440 AND 606 OF THE STANDARD SPECIFICATIONS.

⑦ THE LOCATIONS OF REMOVAL AND REPLACEMENT OF EXISTING CURB OR CURB AND GUTTER SHALL BE DETERMINED BY THE RESIDENT ENGINEER AT THE TIME OF CONSTRUCTION.

SUITABLE BACKFILL MATERIAL (INCLUDED IN THE COST OF CURB OR CURB AND GUTTER REMOVAL AND REPLACEMENT)

PROPOSED 3/4" (20) PREFORMED EXPANSION JOINT AT CONCRETE SIDEWALKS, DRIVEWAYS, AND MEDIANS. (INCLUDED IN THE COST OF CURB OR CURB AND GUTTER REMOVAL AND REPLACEMENT.)

UNSUITABLE SUB-BASE MATERIAL TO BE REMOVED, IF DIRECTED BY THE ENGINEER, SHALL BE REPLACED WITH EITHER SUB-BASE GRANULAR MATERIAL, TYPE B OR ADDITIONAL THICKNESS OF CONCRETE.

REMOVAL AND REPLACEMENT 4" (100) OR LESS IS INCLUDED IN THE COST OF CURB OR CURB AND GUTTER REMOVAL AND REPLACEMENT.

REMOVAL AND REPLACEMENT IN EXCESS OF 4" (100) WILL BE PAID FOR IN ACCORDANCE WITH ARTICLE 109.04 OF THE STANDARD SPECIFICATIONS.

PROPOSED #6 (20) EPOXY COATED TIE BARS 24" (600) LONG AT 24" (600) CENTERS WILL NOT BE PAID FOR SEPARATELY. DELETE EPOXY COATED TIE BARS IF EXISTING TIE BARS ARE USUABLE AS DETERMINED BY THE ENGINEER. (SEE NOTE ③).

**BASIS OF PAYMENT:**

THIS WORK WILL BE PAID FOR AT THE CONTRACT UNIT PRICE PER FOOT (METER) FOR "CURB REMOVAL AND REPLACEMENT" OR "COMBINATION CONCRETE CURB AND GUTTER REMOVAL AND REPLACEMENT".

# CURB OR CURB AND GUTTER REMOVAL AND REPLACEMENT

ALL DIMENSIONS ARE IN INCHES (MILLIMETERS) UNLESS OTHERWISE SHOWN.

FILE NAME = P:\Dtail1-Reinord\bd24.dgn	USER NAME = ahironisb	DESIGNED - A. HOUSEH	REVISED - R. SHAH 10-03-96	<b>STATE OF ILLINOIS DEPARTMENT OF TRANSPORTATION</b>	<b>CURB OR CURB AND GUTTER REMOVAL AND REPLACEMENT</b>			F.A.U. RTE. =	SECTION	COUNTY	TOTAL SHEETS	SHEET NO.	
		DRAWN -	REVISED - A. ABBAS 03-21-97		SCALE: NONE	SHEET NO. 1 OF 1 SHEETS	STA.	TO STA.	3592	(0707, 0707.1 & 0708)	COOK	19	11
		PLOT SCALE = 50.000' / IN.	CHECKED -		REVISED - M. GOMEZ 01-22-01				<b>BD600-06 (BD-24)</b>		CONTRACT NO. 62405		
		PLOT DATE = 3/7/2009	DATE - 03-11-94		REVISED - R. BORO 01-01-07				FED. ROAD DIST. NO. 1 ILLINOIS FED. AID PROJECT				

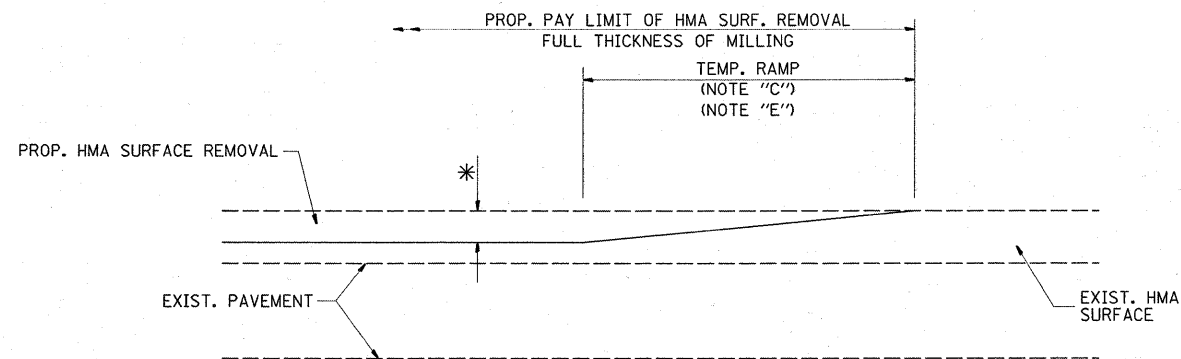

MILLED TEMPORARY RAMP  
(FOR BUTT JOINT AND HMA TAPER SEE DETAIL BELOW)

OPTION 1

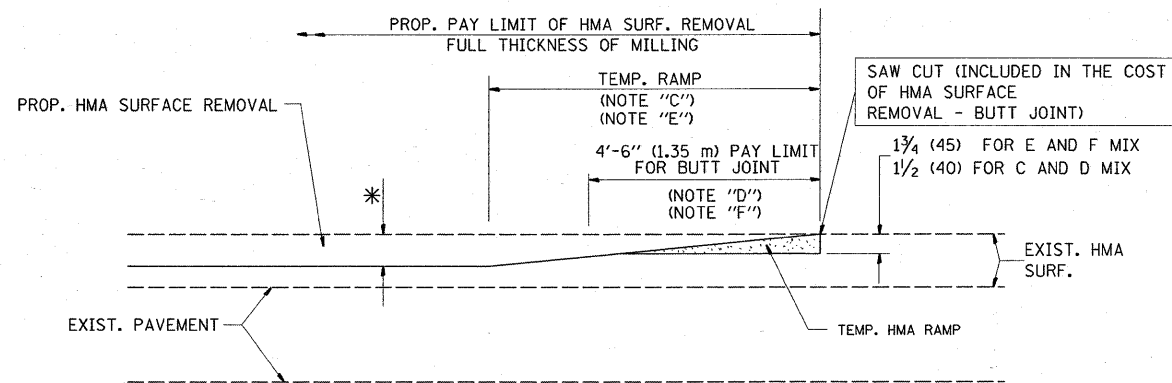

HMA CONSTRUCTED TEMPORARY RAMP  
(FOR BUTT JOINT AND HMA TAPER SEE DETAIL BELOW)

OPTION 2

TYPICAL TEMPORARY RAMP

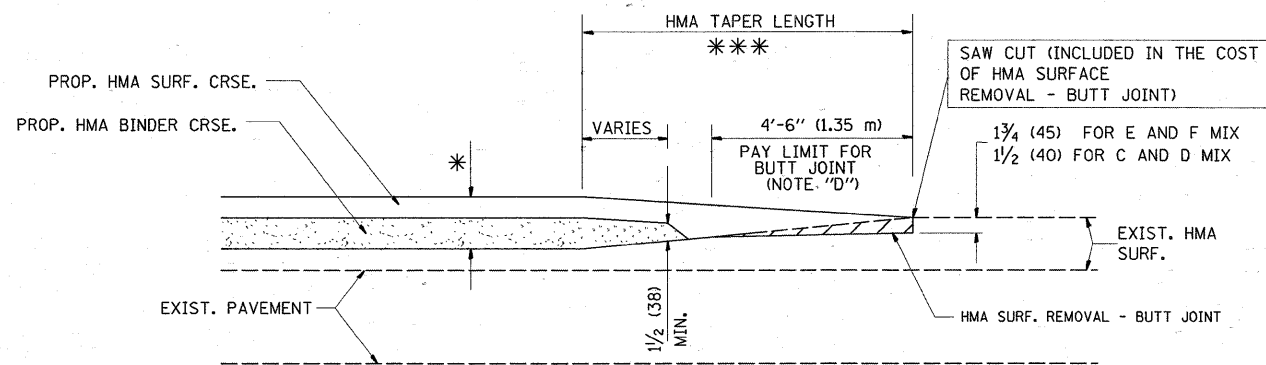

BUTT JOINT AND HMA TAPER  
  
TYPICAL BUTT JOINT AND HMA TAPER  
FOR MILLING AND RESURFACING

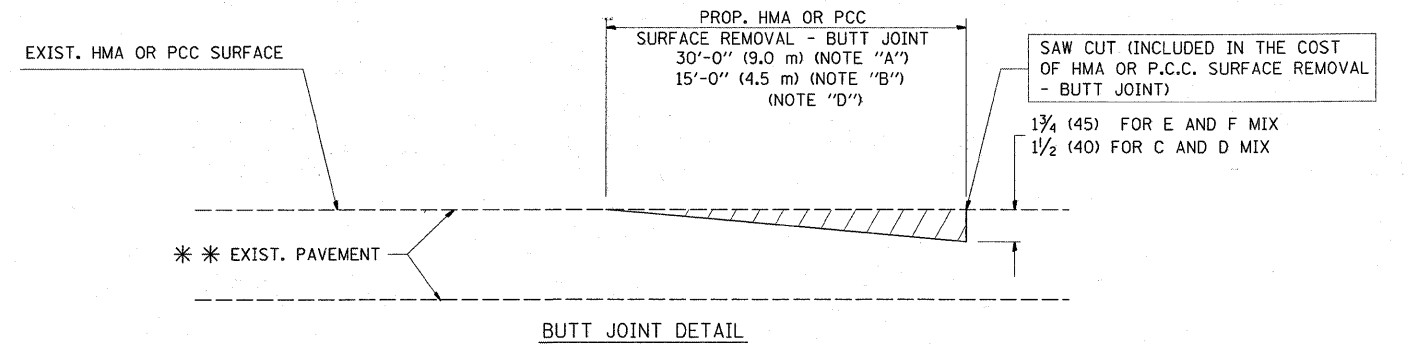

BUTT JOINT DETAIL

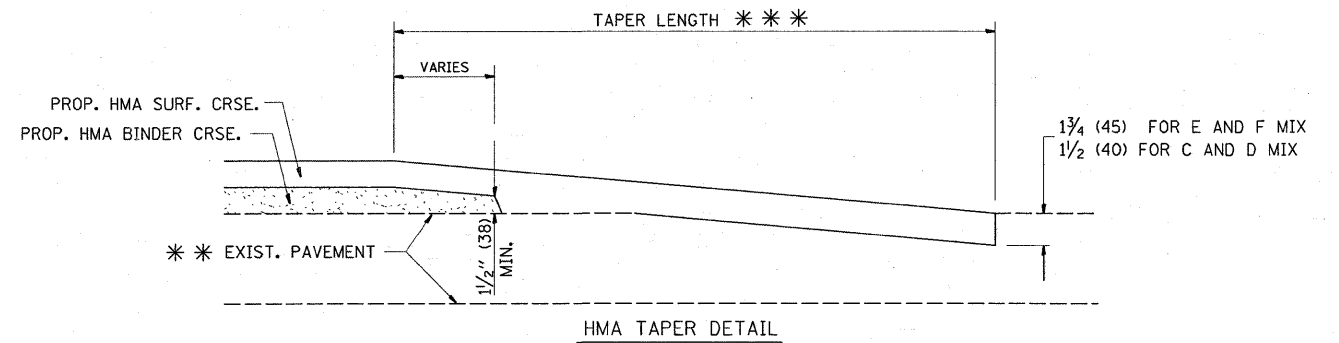

HMA TAPER DETAIL

TYPICAL BUTT JOINT AND HMA TAPER  
FOR RESURFACING ONLY

\*\*\* PC CONCRETE, HMA OR HMA RESURFACED PAVEMENT.

NOTES

- A: MAINLINE ROADWAYS AND MAJOR SIDE ROADS.
  - B: MINOR SIDE ROADS.
  - C: THE TEMP. RAMP SHALL BE CONSTRUCTED IMMEDIATELY UPON REMOVAL OF THE EXISTING HMA SURFACE.
  - D: THE BUTT JOINT SHALL BE CONSTRUCTED IMMEDIATELY PRIOR TO PLACING THE PROPOSED HMA COURSES.
  - E: TAPER THE TEMP. RAMP AT A RATE OF 3'-0" (900 mm) PER 1 INCH (25 mm) OF MILLING THICKNESS.
  - F: INSTALLATION AND REMOVAL OF THE 4'-6" (1.35 m) TEMP. RAMP IS INCLUDED IN COST OF HMA SURFACE REMOVAL - BUTT JOINT
  - G: SEE ARTICLE 406.08 AND 406.14 OF THE STANDARD SPECIFICATIONS FOR "HMA AND/OR PCC SURFACE REMOVAL, BUTT JOINT".
- \* SEE TYPICAL SECTIONS FOR MILLING THICKNESS.
- \*\*\* 20'-0" (6.1 m) PER 1 (25) RESURFACING (NOTE "A")  
10'-0" (3.0 m) PER 1 (25) RESURFACING (NOTE "B")

BASIS OF PAYMENT:

THE BUTT JOINT WILL BE PAID FOR AT THE CONTRACT UNIT PRICE PER SQUARE YARD (SQUARE METER) FOR "HOT-MIX ASPHALT SURFACE REMOVAL - BUTT JOINT" OR FOR "PORTLAND CEMENT CONCRETE SURFACE REMOVAL - BUTT JOINT".

ALL DIMENSIONS ARE IN INCHES (MILLIMETERS) UNLESS OTHERWISE SHOWN.

FILE NAME = P:\N\tail-Brainerd\1\bd32.dgn

USER NAME = shuransib  
PLOT SCALE = 49.9999 // IN.  
PLOT DATE = 3/7/2009

DESIGNED - M. DE YONG  
DRAWN -  
CHECKED -  
DATE - 06-13-90

REVISED - R. SHAH 10-25-94  
REVISED - A. ABBAS 03-21-97  
REVISED - M. GOMEZ 04-06-01  
REVISED - R. BORO 01-01-07

STATE OF ILLINOIS  
DEPARTMENT OF TRANSPORTATION

BUTT JOINT AND  
HMA TAPER DETAILS

SCALE: NONE SHEET NO. 1 OF 1 SHEETS STA. TO STA.

F.A.J. RTE.	SECTION	COUNTY	TOTAL SHEETS	SHEET NO.
3592	(0707, 0707.1 & 0708)	COOK	19	12
BD400-05 BD32		CONTRACT NO. 62405		
FED. ROAD DIST. NO. 1 ILLINOIS FED. AID PROJECT				

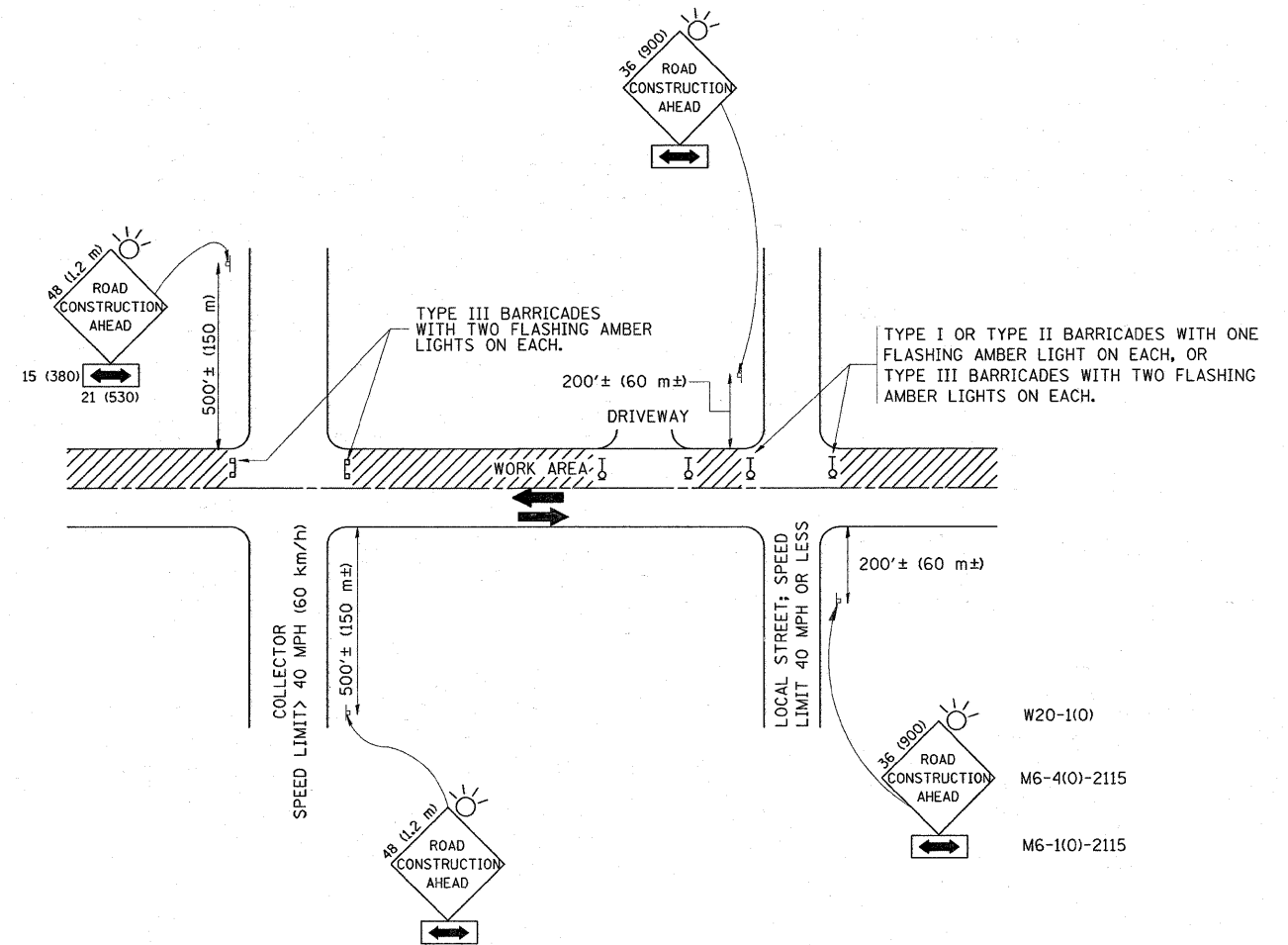

TRAFFIC CONTROL AND PROTECTION FOR SIDE ROADS, INTERSECTIONS, AND DRIVEWAYS

NOTES:

- A. FOR NO LANE RESTRICTION ON THE SIDE ROAD OR DRIVEWAYS
  1. SIDE ROAD WITH A SPEED LIMIT OF 40 MPH (60 km/h) OR LESS AS SHOWN ON THE DRAWING AND AS DIRECTED BY THE ENGINEER:
    - a) ONE ROAD CONSTRUCTION AHEAD SIGN 36 x 36 (900x900) WITH A FLASHER AND FLAG MOUNTED ON IT APPROXIMATELY 200' (60 m) IN ADVANCE OF THE MAIN ROUTE.
    - b) THE CLOSED PORTION OF THE MAIN ROUTE SHALL BE PROTECTED BY BLOCKING WITH TYPE I, TYPE II OR TYPE III BARRICADES, 1/3 OF THE CROSS SECTION OF THE CLOSED PORTION.
  2. SIDE ROAD WITH A SPEED LIMIT GREATER THAN 40 MPH (60 km/h) AS SHOWN ON THE DRAWING AND AS DIRECTED BY THE ENGINEER:
    - a) ONE ROAD CONSTRUCTION AHEAD SIGN 48 x 48 (1.2 m x 1.2 m) WITH A FLASHER MOUNTED ON IT APPROXIMATELY 500' (150 m) IN ADVANCE OF THE MAIN ROUTE.
    - b) THE CLOSED PORTION OF THE MAIN ROUTE SHALL BE PROTECTED BY BLOCKING WITH TYPE III BARRICADES, 1/2 OF THE CROSS SECTION OF THE CLOSED PORTION.
  3. WHEN THE SIDE ROAD LIES BETWEEN THE BEGINNING OF THE MAINLINE SIGNING AND THE WORK ZONE, A SINGLE HEADED ARROW (M6-1) SHALL BE USED IN LIEU OF THE DOUBLE HEADED ARROW (M6-4).
- B. FOR A LANE CLOSURE ON A SIDE ROAD OR DRIVEWAY:
 

USE APPLICABLE PORTIONS OF THE TYPICAL APPLICATION OF TRAFFIC CONTROL DEVICES (STD. 701501, STD. 701606 OR THE APPROPRIATE STANDARD). THE SPACING OF SIGNS AND BARRICADES SHALL BE ADJUSTED FOR FIELD CONDITIONS AS DIRECTED BY THE ENGINEER. THE DIRECTIONAL ARROW SHALL BE COVERED OR REMOVED WHEN NO LONGER CONSISTENT WITH THE SIDE ROAD LANE CLOSURE.
- C. ADVANCE WARNING SIGNS ARE TO BE OMITTED ON DRIVEWAY UNLESS OTHERWISE NOTED.
- D. THE TRAFFIC CONTROL AND PROTECTION FOR SIDE ROADS, INTERSECTIONS, AND DRIVEWAYS SHALL BE INCIDENTAL TO THE COST OF SPECIFIED TRAFFIC CONTROL STANDARDS OR ITEMS.

All dimensions are in inches (millimeters) unless otherwise shown.

FILE NAME = P:\Dtail-Brainard\1\1010.dgn	USER NAME = shiraniab	DESIGNED - LHA	REVISED - J. OBERLE 10-18-95
		DRAWN -	REVISED - A. HOUSEH 03-06-96
	PLOT SCALE = 50.000 ' / IN.	CHECKED -	REVISED - A. HOUSEH 10-15-96
	PLOT DATE = 3/7/2009	DATE - 06-89	REVISED - T. RAMMACHER 01-06-00

STATE OF ILLINOIS  
DEPARTMENT OF TRANSPORTATION

TRAFFIC CONTROL AND PROTECTION FOR  
SIDE ROADS, INTERSECTIONS, AND DRIVEWAYS

SCALE: NONE SHEET NO. 1 OF 1 SHEETS STA. TO STA.

F.A.J. RTE.	SECTION	COUNTY	TOTAL SHEETS	SHEET NO.
3592	(0707, 0707.1 & 0708)	COOK	19	13
TC-10			CONTRACT NO. 62405	
FED. ROAD DIST. NO. 1 [ILLINOIS] FED. AID PROJECT				

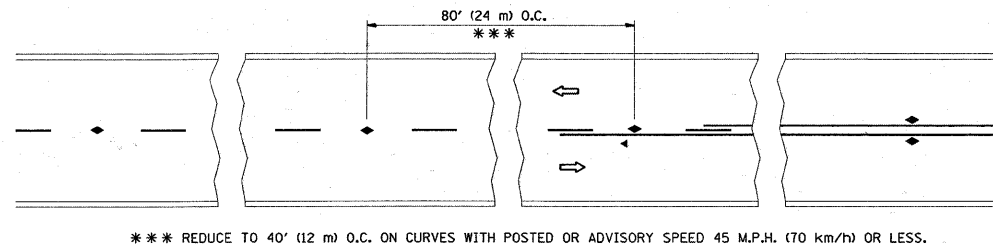

\*\*\* REDUCE TO 40' (12 m) O.C. ON CURVES WITH POSTED OR ADVISORY SPEED 45 M.P.H. (70 km/h) OR LESS.

TWO-LANE/TWO-WAY

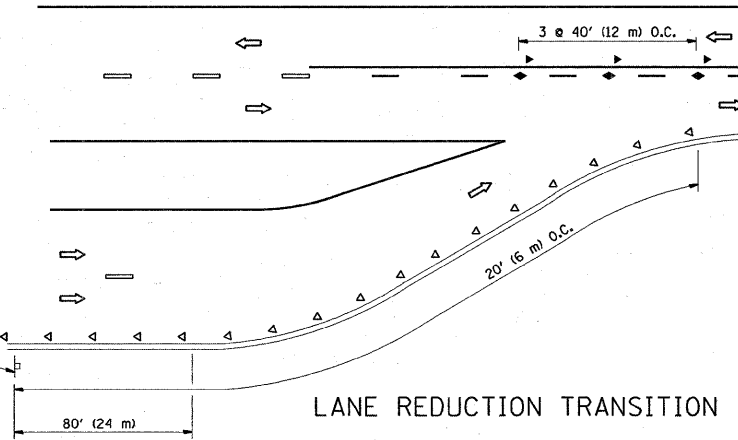

LANE REDUCTION TRANSITION

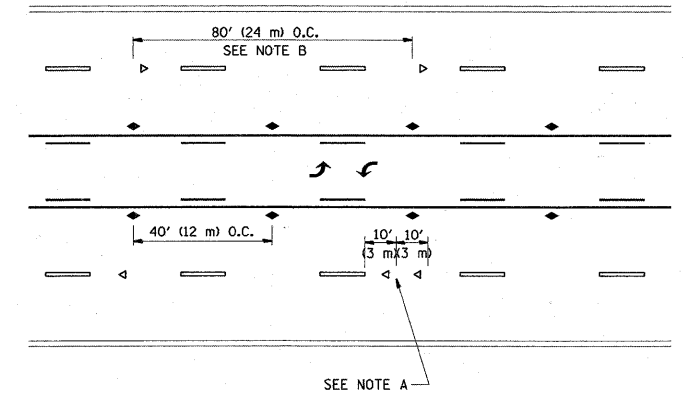

TWO-WAY LEFT TURN

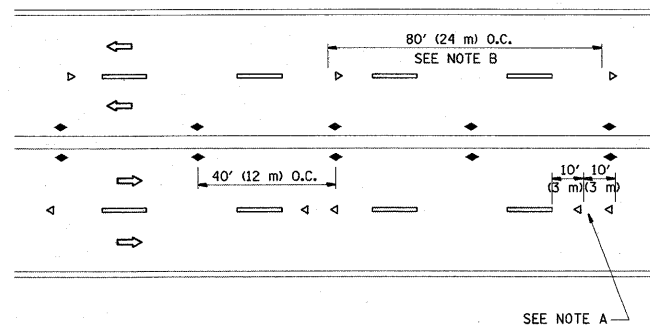

MULTI-LANE/UNDIVIDED

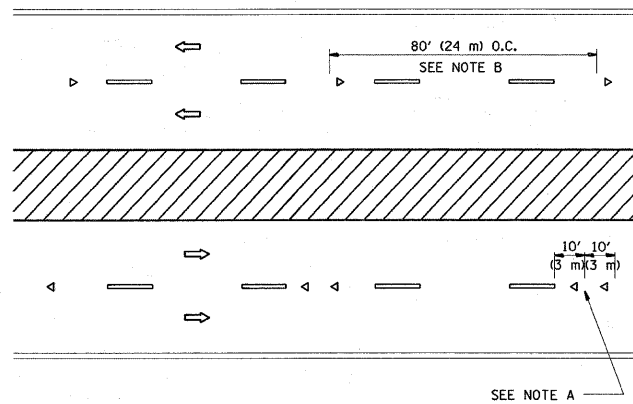

MULTI-LANE/DIVIDED

GENERAL NOTES

1. MARKERS USED WITH DASHED LINES SHALL BE CENTERED IN THE GAP BETWEEN SEGMENTS.
2. MARKERS USED ADJACENT TO SOLID LINES SHALL BE OFFSET 2 TO 3 (50 TO 75) TOWARD TRAFFIC AS SHOWN.
3. MARKERS THROUGH TANGENTS LESS THAN 500' (150 m) IN LENGTH BETWEEN CURVES SHALL BE INSTALLED AT THE LESSER OF THE TWO CURVE SPACINGS.

SYMBOLS

- YELLOW STRIPE
- WHITE STRIPE
- ◀ ONE-WAY AMBER MARKER
- ◀ ONE-WAY CRYSTAL MARKER (W/O)
- ◆ TWO-WAY AMBER MARKER

LANE MARKER NOTES

- B. REDUCE TO 40' (12 m) O.C. ON CURVES WHERE ADVISORY SPEEDS ARE 10 M.P.H. (20 km/h) LOWER THAN POSTED SPEEDS.
- A. USE DOUBLE LANE LINE MARKERS SPACED AS SHOWN.

DESIGN NOTES

1. DOUBLE LANE LINE MARKERS SHALL BE USED UNLESS SPECIFIED OTHERWISE.
2. EXCEPT AS SHOWN ON THE LANE REDUCTION TRANSITION AND FREEWAY EXIT RAMP DETAIL, MARKERS ARE NOT TO BE SPECIFIED ON RIGHT EDGE LINES.
3. THE EXACT MARKER LIMITS, SPACING, AND COLOR SHOULD BE INCLUDED IN THE PLANS.
4. MARKERS SHOULD NOT BE USED ALONGSIDE CURBS EXCEPT FOR EXTREMELY SHORT SECTIONS OF CURBS WHERE NOT MORE THAN TWO MARKERS WOULD BE INVOLVED.

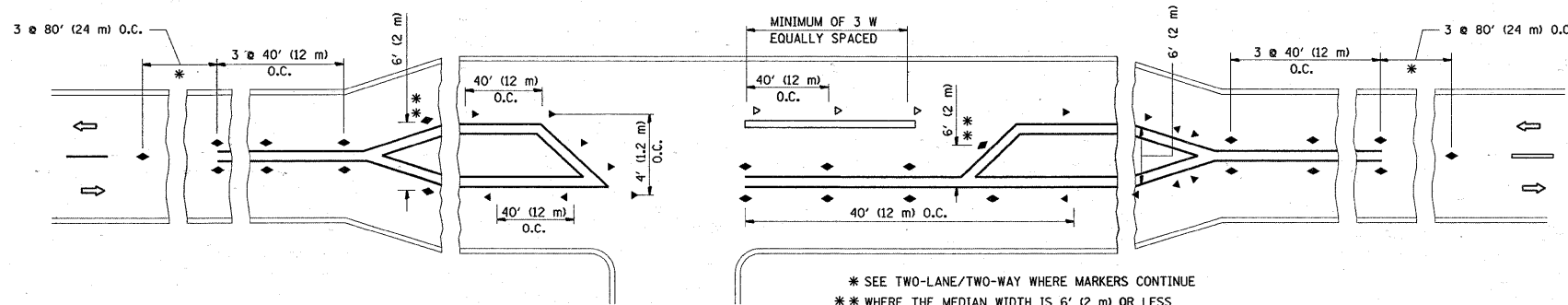

LEFT TURN

\* SEE TWO-LANE/TWO-WAY WHERE MARKERS CONTINUE  
\*\* WHERE THE MEDIAN WIDTH IS 6' (2 m) OR LESS USE TWO-WAY MARKERS.

All dimensions are in inches (millimeters) unless otherwise shown.



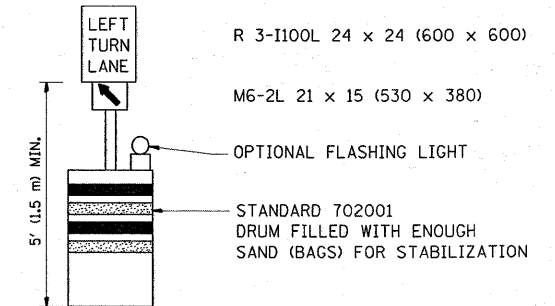
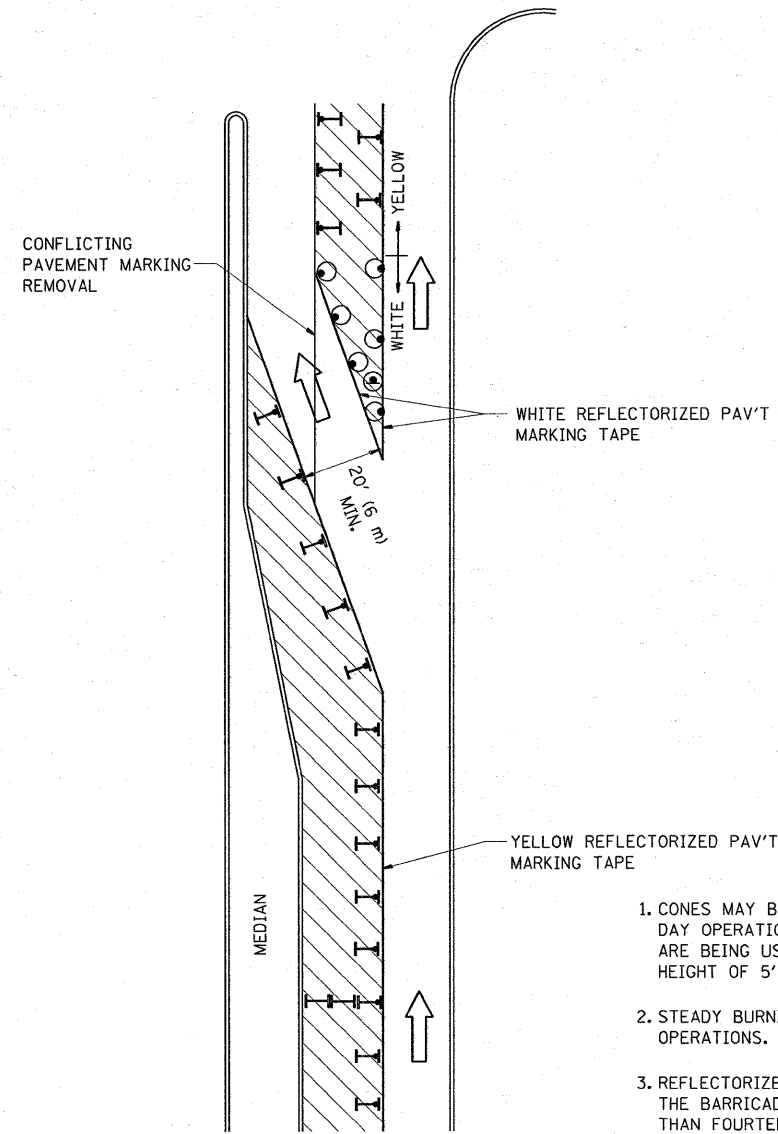



FILE NAME = P:\Dtail-Brainard\1\toill.dgn	USER NAME = shuranisb	DESIGNED -	REVISED - T. RAMMACHER 09-19-94	<b>STATE OF ILLINOIS DEPARTMENT OF TRANSPORTATION</b>	<b>TYPICAL APPLICATIONS RAISED REFLECTIVE PAVEMENT MARKERS (SNOW-PLOW RESISTANT)</b>			F.A.J. RTE. 3592	SECTION (0707, 0707.1 & 0708)	COUNTY COOK	TOTAL SHEETS 19	SHEET NO. 14
	PLOT SCALE = 50,000' / IN.	DRAWN -	REVISED - T. RAMMACHER 03-12-99		SCALE: NONE	SHEET NO. 1 OF 1 SHEETS	STA. TO STA.	<b>TC-11</b>				
	PLOT DATE = 3/7/2009	CHECKED -	REVISED - T. RAMMACHER 01-06-00		CONTRACT NO. 62405							
		DATE -	REVISED -		FED. ROAD DIST. NO. 1 [ILLINOIS] FED. AID PROJECT							

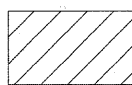

**GENERAL NOTES**

1. CONES MAY BE SUBSTITUTED FOR BARRICADES OR DRUMS AT HALF THE SPACING DURING DAY OPERATIONS. CONES SHALL BE A MINIMUM OF 28 (710) IN HEIGHT. WHEN CONES ARE BEING USED, THE "LEFT TURN LANE" SIGN MAY BE SKID MOUNTED AT A MINIMUM HEIGHT OF 5' (1.5 m).
2. STEADY BURNING LIGHTS WILL NOT BE REQUIRED ON BARRICADES OR DRUMS FOR DAY OPERATIONS. ALL LIGHTS SHALL BE MONODIRECTIONAL.
3. REFLECTORIZED TEMPORARY PAVEMENT MARKING TAPE SHALL BE PLACED THROUGHOUT THE BARRICADED AREA OF EACH TURN BAY WHERE THE CLOSURE TIME IS GREATER THAN FOURTEEN DAYS.
4. THIS APPLICATION ALSO APPLIES WHEN WORK IS BEING PERFORMED IN THE RIGHT LANE(S) AND THE RIGHT TURN BAY IS TO REMAIN OPEN. UNDER THIS CONDITION, "RIGHT TURN LANE" R3-100 24 x 24 (600 x 600) AND M6-2R 21 x 15 (530 x 380) SHALL BE USED.
5. THESE CONTROLS SHALL SUPPLEMENT MAINLINE TRAFFIC CONTROL FOR LANE CLOSURES.
6. LONGITUDINAL DIMENSIONS MAY BE ADJUSTED TO FIT FIELD CONDITIONS.
7. FORM BT 725 IS REQUIRED.
8. TRAFFIC CONTROL AND PROTECTION AT TURN BAYS (TO REMAIN OPEN TO TRAFFIC) SHALL BE INCLUDED IN THE COST SPECIFIED TRAFFIC CONTROL STANDARDS OR ITEMS.

**LEGEND**

-  WORK AREA
-  LANE OPEN TO TRAFFIC
-  TYPE I OR II BARRICADE WITH STEADY BURN LIGHT
-  DRUM WITH STEADY BURN LIGHT
-  DRUM WITH SIGN (WITH OPTIONAL FLASHING LIGHT) SEE DETAIL
-  TYPE I OR II CHECK BARRICADE WITH FLASHING LIGHT

All dimensions are in inches (millimeters) unless otherwise shown.

FILE NAME =	USER NAME = shurenisb	DESIGNED -	REVISED -T. RAMMACHER 09-08-94
Pa\Dot1-Brainard1\14.dgn		DRAWN -	REVISED - A. HOUSEH 11-07-95
	PLOT SCALE = 49.9999 / IN.	CHECKED -	REVISED - A. HOUSEH 10-12-96
	PLOT DATE = 3/7/2009	DATE -	REVISED -T. RAMMACHER 01-06-00

**STATE OF ILLINOIS  
DEPARTMENT OF TRANSPORTATION**

<b>TRAFFIC CONTROL AND PROTECTION AT TURN BAYS (TO REMAIN OPEN TO TRAFFIC)</b>			
SCALE: NONE	SHEET NO. 1 OF 1 SHEETS	STA.	TO STA.

F.A.U. RTE.	SECTION	COUNTY	TOTAL SHEETS	SHEET NO.
3592	(0707, 0707.1 & 0708)	COOK	19	15
TC-14			CONTRACT NO. 62405	
FED. ROAD DIST. NO. 1 ILLINOIS FED. AID PROJECT				

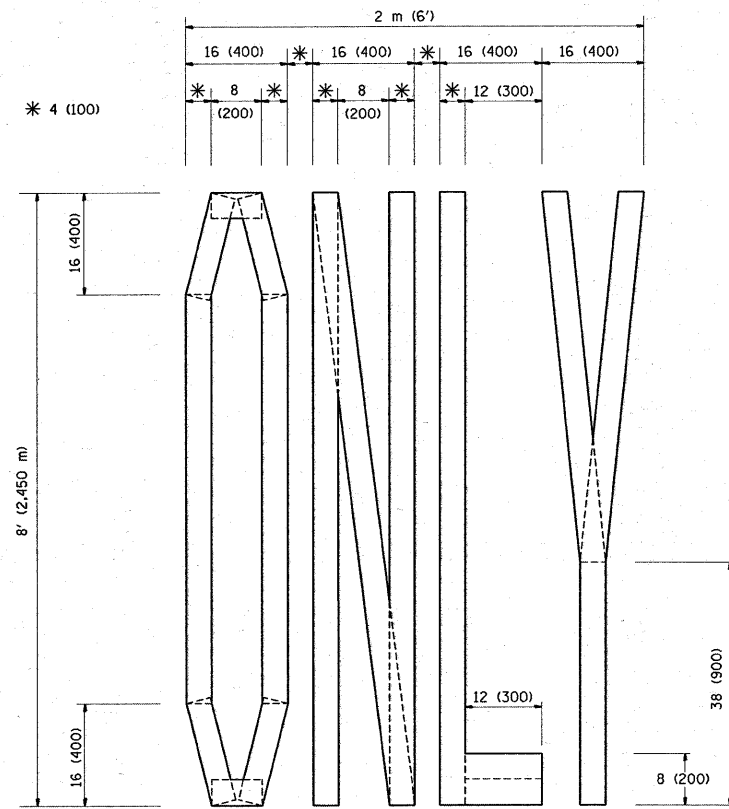

QUANTITY  
 4 (100) LINE = 64.1 ft. (19.7 m)  
 21.1 sq. ft. (1.97 sq. m)

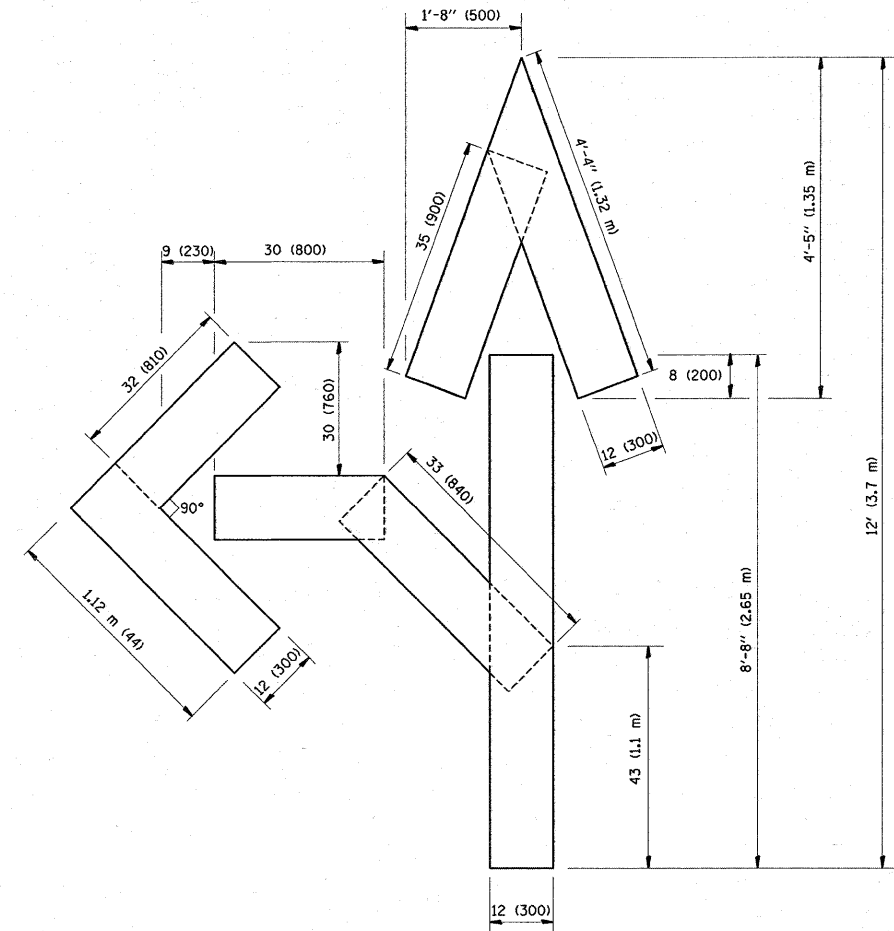

QUANTITY  
 4 (100) LINE = 82.5 ft. (25.3 m)  
 27.5 sq. ft. (2.53 sq. m)

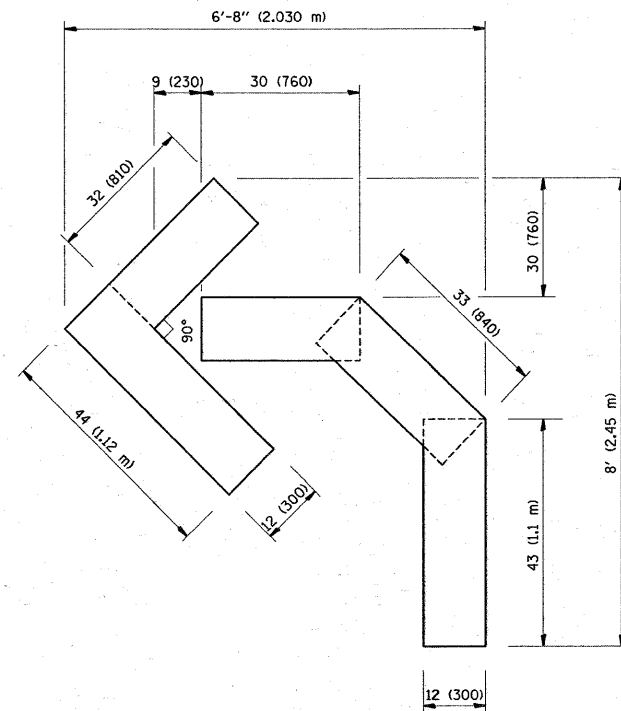

QUANTITY  
 4 (100) LINE = 45.5 ft. (13.9 m)  
 15.2 sq. ft. (1.39 sq. m)

All dimensions are in inches (millimeters) unless otherwise shown.

FILE NAME = P:\Dtd\1-Breunard\1\c16.dgn	USER NAME = shiranisb	DESIGNED -	REVISED -T. RAMMACHER 06-05-96
		DRAWN -	REVISED -T. RAMMACHER 11-04-97
	PLOT SCALE = 49.9999 / IN.	CHECKED -	REVISED -T. RAMMACHER 03-02-98
	PLOT DATE = 3/7/2009	DATE - 09-18-94	REVISED -E. GOMEZ 08-28-00

STATE OF ILLINOIS  
 DEPARTMENT OF TRANSPORTATION

PAVEMENT MARKING LETTERS AND SYMBOLS  
 FOR TRAFFIC STAGING

SCALE: NONE SHEET NO. 1 OF 1 SHEETS STA. TO STA.

F.A.J. RTE.	SECTION	COUNTY	TOTAL SHEETS	SHEET NO.
3592	(0707, 0707.1 & 0708)	COOK	19	16
TC-16			CONTRACT NO. 62405	
FED. ROAD DIST. NO. 1 ILLINOIS FED. AID PROJECT				



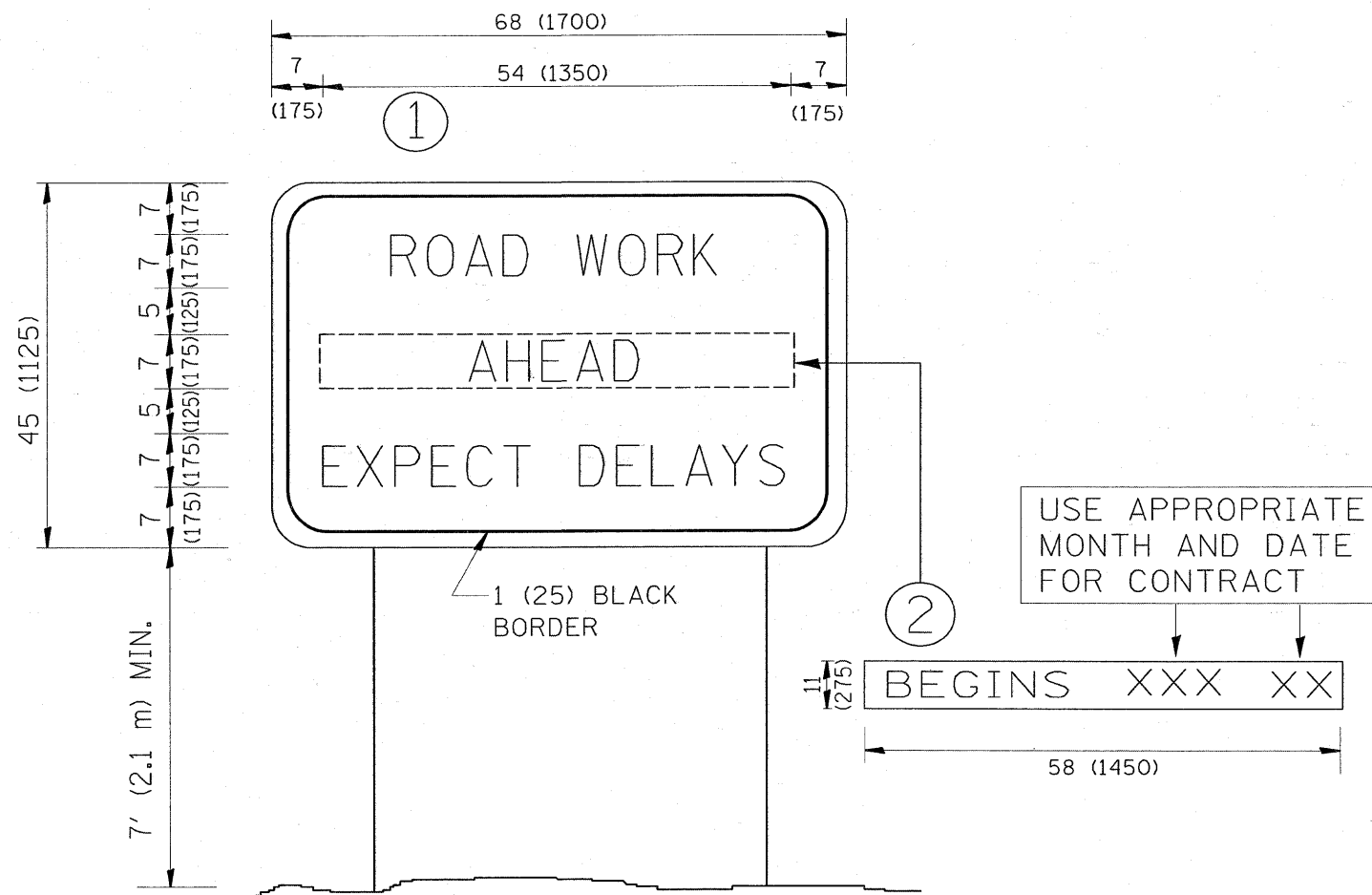

**NOTES:**

1. USE BLACK LETTERING ON ORANGE BACKGROUND.
2. ERECT SIGNS IN ADVANCE OF THE LOCATION FOR THE "ROAD CONSTRUCTION AHEAD" SIGN AT LOCATIONS AS DIRECTED BY THE ENGINEER.
3. ERECT SIGN ① WITH INSTALLED PANEL ② ONE WEEK PRIOR TO THE START OF CONSTRUCTION.
4. REMOVE PANEL ② SOON AFTER THE START OF CONSTRUCTION.
5. SEE SPECIAL PROVISION FOR "TEMPORARY INFORMATION SIGNING" FOR ADDITIONAL INFORMATION.
6. ONE SIGN ASSEMBLY EQUALS 25.70 SQ. FT. (2.3 SQ. M.)
7. SHALL BE PAID FOR AS TEMPORARY INFORMATION SIGNING.

ALL DIMENSIONS ARE IN INCHES (MILLIMETERS) UNLESS OTHERWISE SHOWN.

FILE NAME = P:\Dtsai-Brainerd\to22.dgn	USER NAME = shiranisb	DESIGNED -	REVISED - R. MIRS 09-15-97	<b>STATE OF ILLINOIS DEPARTMENT OF TRANSPORTATION</b>	<b>ARTERIAL ROAD INFORMATION SIGN</b>	F.A.U. RTE.	SECTION	COUNTY	TOTAL SHEETS	SHEET NO.	
		DRAWN -	REVISED - R. MIRS 12-11-97			3592	(0707, 0707.1 & 0708)	COOK	19	17	
		CHECKED -	REVISED - T. RAMMACHER 02-02-99			<b>TC-22</b>		CONTRACT NO. 62405			
		DATE -	REVISED - C. JUCIUS 01-31-07			SCALE: NONE	SHEET NO. 1 OF 1 SHEETS	STA. TO STA.	FED. ROAD DIST. NO. 1   ILLINOIS FED. AID PROJECT		

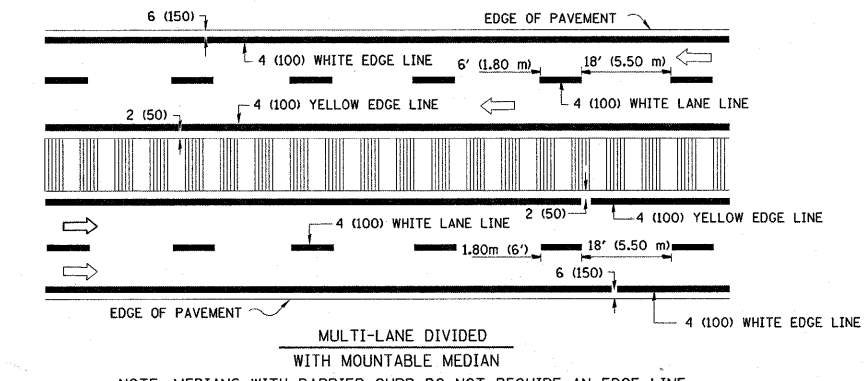
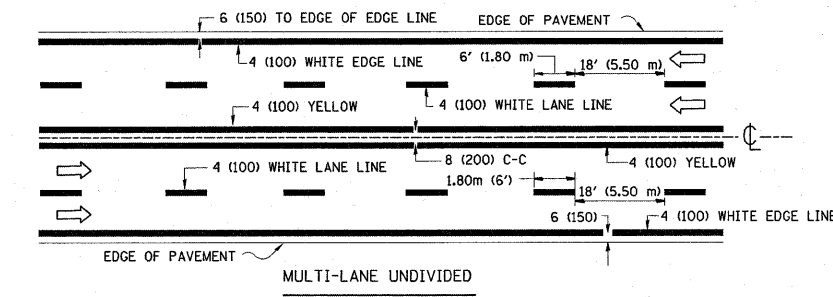
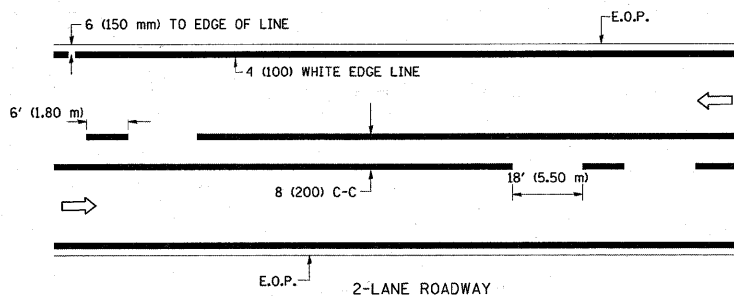

NOTE: MEDIANS WITH BARRIER CURBS DO NOT REQUIRE AN EDGE LINE

**TYPICAL LANE AND EDGE LINE MARKING**

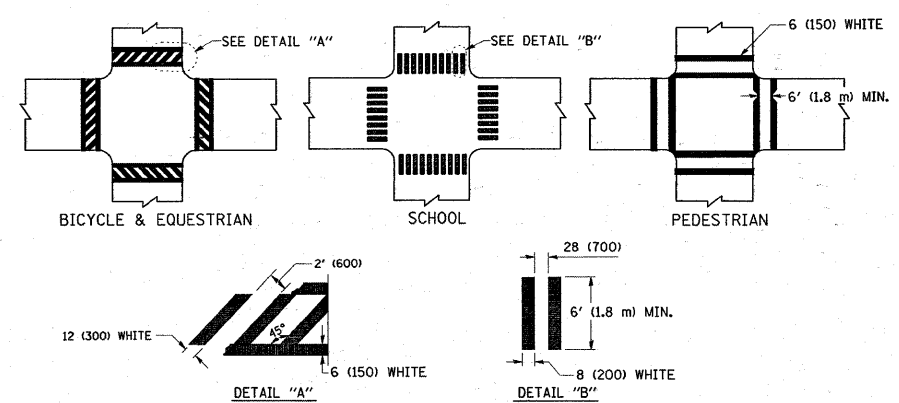

**TYPICAL CROSSWALK MARKING**

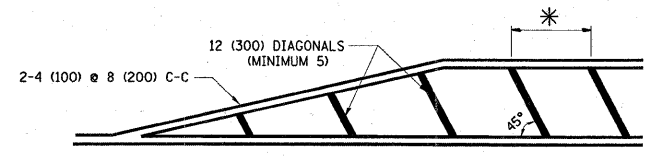

\* FOR MEDIAN LENGTHS WHERE DIAGONAL SPACING CANNOT BE ATTAINED, USE 5 (FIVE) EQUALLY SPACED DIAGONAL LINES.  
\* DIAGONAL LINE SPACING: 20' (6.1 m) C-C

**PAINTED MEDIANS**

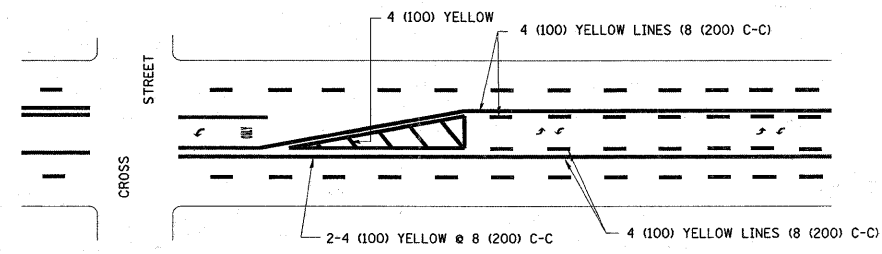

A MINIMUM OF TWO PAIRS OF TURN ARROWS SHALL BE USED, WHITE IN COLOR. ADDITIONAL PAIRS SHALL BE PLACED AT 200' (60 m) TO 300' (90 m) INTERVALS.

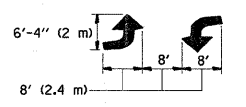

**MEDIAN WITH TWO-WAY LEFT TURN LANE**

**TYPICAL PAINTED MEDIAN MARKING**

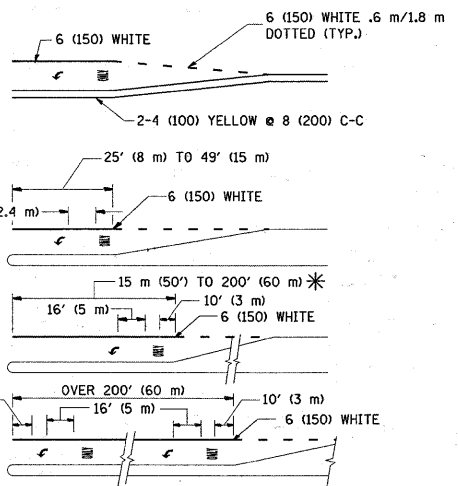

FULL SIZE LETTERS 8' (2.4 m) AND ARROWS SHALL BE USED.  
AREA = 15.8 SQ. FT. (1.47 m<sup>2</sup>) ONLY AREA = 22.9 SQ. FT. (2.13 m<sup>2</sup>)  
\* TURN LANES IN EXCESS OF 400' (120 m) IN LENGTH MAY HAVE AN ADDITIONAL SET OF ARROW - "ONLY" INSTALLED MIDWAY BETWEEN THE OTHER TWO SETS OF ARROW - "ONLY".

**TYPICAL LEFT (OR RIGHT) TURN LANE**

**TYPICAL TURN LANE MARKING**

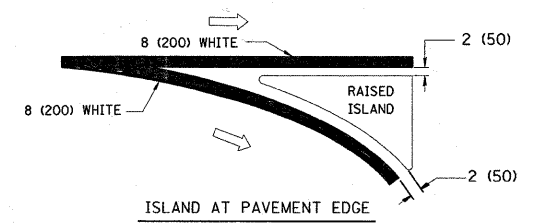
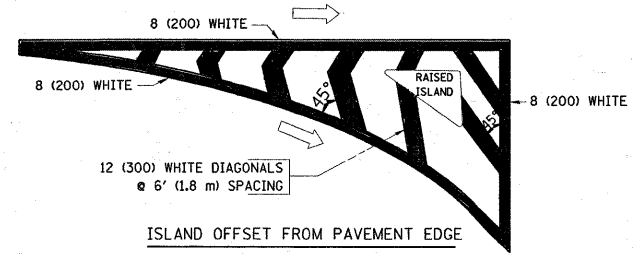

**TYPICAL ISLAND MARKING**

TYPE OF MARKING	WIDTH OF LINE	PATTERN	COLOR	SPACING / REMARKS
CENTERLINE ON 2 LANE PAVEMENT	4 (100)	SKIP-DASH	YELLOW	6' (1.80 m) LINE WITH 18' (5.50 m) SPACE
CENTERLINE ON MULTI-LANE UNDIVIDED PAVEMENT	2 @ 4 (100)	SOLID	YELLOW	8 (200) C-C
NO PASSING ZONE LINES: FOR ONE DIRECTION FOR BOTH DIRECTIONS	4 (100) 2 @ 4 (100)	SOLID SOLID	YELLOW YELLOW	8 (200) C-C
LANE LINES	4 (100) 5 (125) ON FREEWAYS	SKIP-DASH SKIP-DASH	WHITE WHITE	6' (1.80 m) LINE WITH 18' (5.50 m) SPACE
DOTTED LINES (EXTENSIONS OF CENTER, LANE OR TURN LANE MARKINGS)	SAME AS LINE BEING EXTENDED	SKIP-DASH	SAME AS LINE BEING EXTENDED	2' (600) LINE WITH 6' (1.8) SPACE
EDGE LINES	4 (100)	SOLID	YELLOW-LEFT WHITE-RIGHT	OUTLINE MOUNTABLE MEDIANS IN YELLOW; EDGE LINES ARE NOT USED NEXT TO BARRIER CURB
TURN LANE MARKINGS	6 (150) LINE; FULL SIZE LETTERS & SYMBOLS (8' (2.4 m))	SOLID	WHITE	SEE TYPICAL TURN LANE MARKING DETAIL
TWO WAY LEFT TURN MARKING	2 @ 4 (100) EACH DIRECTION 8' (2.4 m) LEFT ARROW	SKIP-DASH AND SOLID IN PAIRS	YELLOW WHITE	6' (1.8 m) LINE WITH 18' (5.50 m) SPACE FOR SKIP-DASH; 8 (200) C-C BETWEEN SOLID LINE AND SKIP-DASH LINE SEE TYPICAL TWO-WAY LEFT TURN MARKING DETAIL
CROSSWALK LINES (PEDESTRIAN) A. DIAGONALS (BIKE & EQUESTRIAN) B. LONGITUDINAL BARS (SCHOOL)	2 @ 6 (150) 12 (300) @ 45° 8 (200) @ 90°	SOLID SOLID SOLID	WHITE WHITE WHITE	NOT LESS THAN 6' (1.8 m) APART 2' (600) APART SEE TYPICAL CROSSWALK MARKING DETAILS.
STOP LINES	24 (600)	SOLID	WHITE	PLACE 4' (1.2 m) IN ADVANCE OF AND PARALLEL TO CROSSWALK, IF PRESENT. OTHERWISE, PLACE AT DESIRED STOPPING POINT. PARALLEL TO CROSSROAD CENTERLINE, WHERE POSSIBLE
PAINTED MEDIANS	2 @ 4 (100) WITH 12 (300) DIAGONALS @ 45°	SOLID	YELLOW; TWO WAY TRAFFIC WHITE; ONE WAY TRAFFIC	8 (200) C-C FOR THE DOUBLE LINE SEE TYPICAL PAINTED MEDIAN MARKING.
CORE MARKING AND CHANNELIZING LINES	8 (200) WITH 12 (300) DIAGONALS @ 45°	SOLID	WHITE	DIAGONALS: 20' (6.1 m) (LESS THAN 30 MPH (50 km/h))
RAILROAD CROSSING	24 (600) TRANSVERSE LINES; "RR" IS 6' (1.8 m) LETTERS; 16 (400) LINE FOR "X"	SOLID	WHITE	SEE STATE STANDARD 780001 AREA OF: "R"=3.6 SQ. FT. (0.33m <sup>2</sup> ) EACH "X"=54.0 SQ. FT. (5.0 m <sup>2</sup> )

FOR FURTHER DETAILS ON PAVEMENT MARKING REFER TO STREET MARKING STANDARDS, PRINTED BY CITY OF CHICAGO, DEPARTMENT OF TRANSPORTATION, BUREAU OF TRAFFIC.

ALL DIMENSIONS ARE IN INCHES (MILLIMETERS) UNLESS OTHERWISE SHOWN.

FILE NAME = P:\Dtail-Brainard\to24.dgn	USER NAME = shirantab	DESIGNED -	REVISED - T. RAMMACHER 12-07-00
		DRAWN -	REVISED -
	PLOT SCALE = 50.0000 "/ IN.	CHECKED -	REVISED -
	PLOT DATE = 3/7/2009	DATE -	REVISED -

**STATE OF ILLINOIS  
DEPARTMENT OF TRANSPORTATION**

<b>CITY OF CHICAGO TYPICAL PAVEMENT MARKINGS</b>	
SCALE: NONE	SHEET NO. 1 OF 2 SHEETS STA. TO STA.

F.A.U. RTE.	SECTION	COUNTY	TOTAL SHEETS	SHEET NO.
3592	(0707, 0707.1 & 0708)	COOK	19	18
TC-24		CONTRACT NO. 62405		
FED. ROAD DIST. NO. 1 ILLINOIS FED. AID PROJECT				

