

EXISTING TYPICAL SECTION  
GREENBAY RD (LOC. 1) AND CENTRAL STREET (LOC.2)

STA. 1+00 TO STA. 5+96 (LOC. 1)  
(STA. 150+60 TO STA. 171+27 LOC. 2)

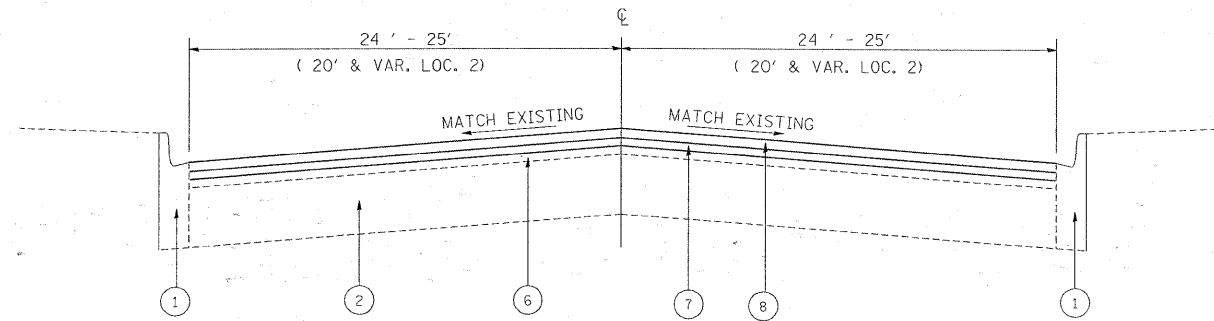

PROPOSED TYPICAL SECTION  
GREENBAY RD (LOC. 1) AND CENTRAL STREET (LOC.2)

STA. 1+00 TO STA. 5+96 (LOC. 1)  
(STA. 150+60 TO STA. 171+27 LOC. 2)

**LEGEND**

1. EXISTING COMBINATION CONCRETE CURB AND GUTTER
2. EXISTING P.C. CONCRETE PAVEMENT ± 8"
3. TOTAL EXISTING HOT-MIX ASPHALT ± 4"
4. PROPOSED HMA SURFACE REMOVAL, 2-1/4"
5. PROPOSED HMA SURFACE REMOVAL (VARIABLE DEPTH 1" TO 1-1/2")
6. HMA OVERLAY AFTER MILLING
7. PROPOSED POLYMERIZED LEVELING BINDER (MACHINE METHOD), IL-4.75, N50, 3/4"
8. PROPOSED HMA SURFACE COURSE, MIX "D", N70, 1-1/2"
9. PROPOSED HMA SURFACE COURSE, MIX "D", N70, VARIABLE DEPTH - 1" TO 1-1/2"

**THE CONTRACTOR SHALL PATCH FIRST BEFORE MILLING**

FILE NAME =	USER NAME = gorengautab	DESIGNED -	REVISED -	<b>STATE OF ILLINOIS DEPARTMENT OF TRANSPORTATION</b>	<b>CENTRAL STREET (McDANIEL AVE. TO ASHLAND AVE. AND ASBURY AVE. TO SHERMAN AVE.) TYPICAL CROSS SECTIONS</b>	F.A.U RTE. 1301	SECTION (0506 & 0607) RS-7	COUNTY COOK	TOTAL SHEETS 19	SHEET NO. 5		
ea:\pwork\pwork\GORENGAUTAB\d0139026	0125304-sht-plan.dgn	DRAWN -	REVISED -			SCALE:	SHEET NO. OF SHEETS	STA.	TO STA.	ILLINOIS FED. AID PROJECT		
	PLOT SCALE = 50,0000' / IN.	CHECKED -	REVISED -							CONTRACT NO. 62784		
	PLOT DATE = 4/23/2009	DATE -	REVISED -									