

STATE OF ILLINOIS  
DEPARTMENT OF TRANSPORTATION  
DIVISION OF HIGHWAYS

**PROPOSED  
HIGHWAY PLANS**

F.A.S. ROUTE 1476 (OLD U.S. 51)  
SECTION (55,56)RS-3

MCLEAN COUNTY

C-95-032-06

RESURFACING (3P)  
2.5 MI. S. OF I-74 to 1 MI. S. OF HEYWORTH

F.A.S. RTE.	SECTION	COUNTY	TOTAL SHEETS	SHEET NO.
1476	(55,56)RS-3	McLean	24	1
		ILLINOIS	CONTRACT NO. 70511	

FOR INDEX OF SHEETS, SEE SHEET NO. 2  
FOR SUMMARY OF QUANTITIES, SEE SHEET NO. 4

**CURRENT ADT**  
2500 - (2007)  
MINOR ARTERIAL (RURAL)

**DESIGN DESIGNATION**  
N/A

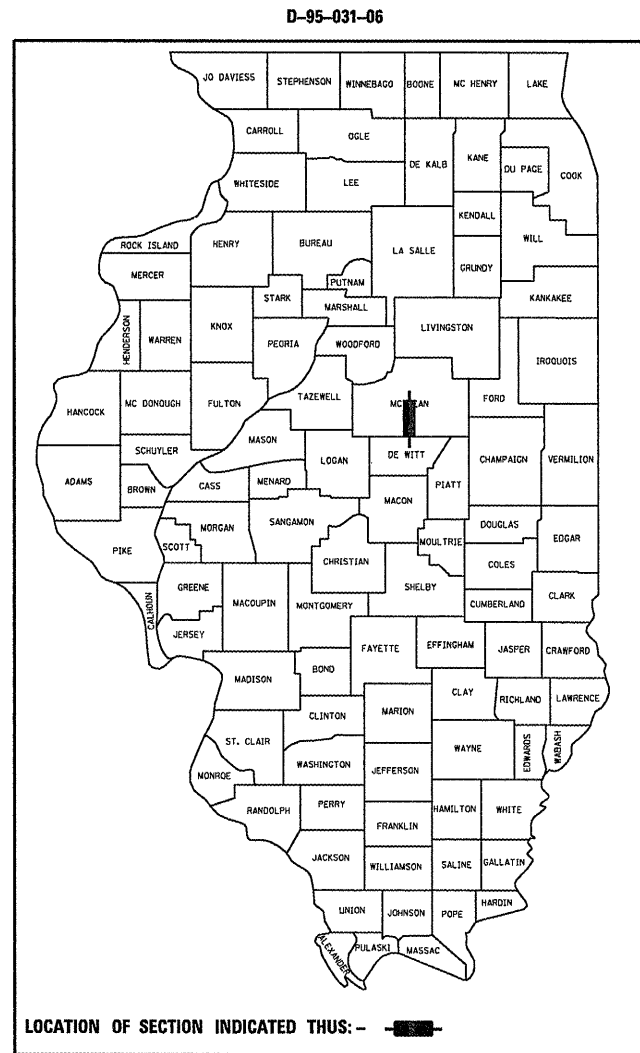

OMISSIONS FROM PAVING

US 136 - INTERSECTION,  
SN 057-0225 - BRIDGE,  
SN 057-0056 - BRIDGE,  
SN 057-8208 - CULVERT,  
SN 057-8207 - CULVERT,  
SN 057-8209 - CULVERT,

END PROJECT  
TR 800 N. RD STA. 446+92.80

STA. 106+00 TO STA. 108+00  
STA. 133+20.55 TO STA. 134+11.45  
STA. 158+59.74 TO STA. 160+79.46  
STA. 271+65 TO STA. 271+95  
STA. 289+63 TO STA. 289+97  
STA. 310+22 TO STA. 310+56

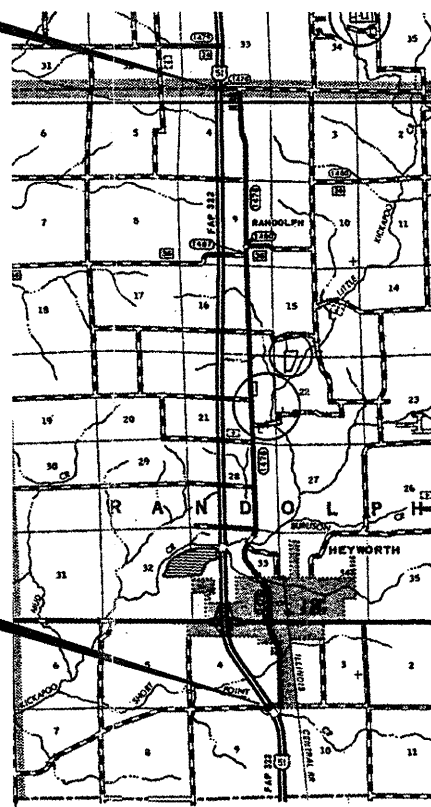

BEGIN PROJECT  
TR 100 N. RD STA. 51+96.00

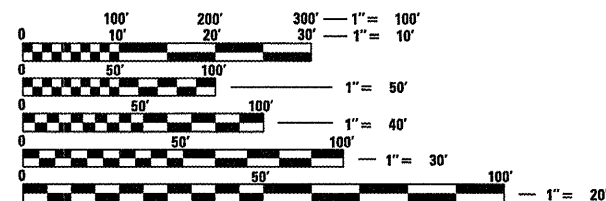
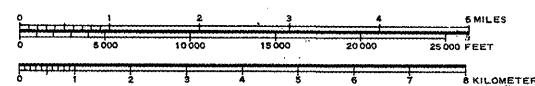

FULL SIZE PLANS HAVE BEEN PREPARED USING STANDARD ENGINEERING SCALES. REDUCED SIZED PLANS WILL NOT CONFORM TO STANDARD SCALES. IN MAKING MEASUREMENTS ON REDUCED PLANS, THE ABOVE SCALES MAY BE USED.

J.U.L.I.E.  
JOINT UTILITY LOCATION INFORMATION FOR EXCAVATION  
1-800-892-0123  
OR 811 TOWNSHIPS: RANDOLPH & EMPIRE

PROJECT ENGINEER: NANCY FASIG  
SQUAD LEADER: JASON W. STULTS  
DESIGNER: MATT YOUNG  
CONTRACT NO. 70511

GROSS LENGTH = 39,496.00 FT. = 7.480 MILES  
NET LENGTH = 39,069.60 FT. = 7.400 MILES

STATE OF ILLINOIS  
DEPARTMENT OF TRANSPORTATION  
DIVISION OF HIGHWAYS

SUBMITTED 4/29 2009  
*Joseph E. Rowe*  
DEPUTY DIRECTOR OF HIGHWAYS, REGION ENGINEER  
March 13, 2009  
*Charles J. Ingersoll*  
ENGINEER OF DESIGN AND ENVIRONMENT  
March 13, 2009  
*Christine M. Reed*  
DIRECTOR OF HIGHWAYS, CHIEF ENGINEER

PRINTED BY THE AUTHORITY  
OF THE STATE OF ILLINOIS

## INDEX OF SHEETS

1	COVER SHEET
2	INDEX OF SHEETS/STANDARDS
3	GENERAL NOTES
4	SUMMARY OF QUANTITIES
5-6	TYPICAL SECTIONS
7	LOCATION MAP
8-10	SCHEDULES
11	DETAIL OF HMA SURF. REM. SPECIAL & BUTT JOINTS
12	DETAIL OF MAILBOX TURNOUT (RURAL)
13-14	DETAIL OF SIDEROADS & SIDESTREETS (RURAL)
15-16	DETAIL OF FIELD ENTRANCES (NONCOMMERICAL RURAL)
17-18	DETAIL OF PRIVATE & COMMERCIAL ENTRANCES (NONCOMMERCIAL & COMMERCIAL RURAL)
19	DETAIL OF TRAFFIC CONTROL & PROTECTION DEVICES (ROAD & SIDEROAD/STREET CLOSURES)
20-23	DETAIL OF PAVEMENT MARKING & MARKERS (RURAL & URBAN APPLICATIONS)
24	DETAIL OF PRECAST BOX CULVERT END SECTION (M273)

## HIGHWAY STANDARDS

000001-05	STANDARD SYMBOLS, ABBREVIATIONS AND PATTERNS
001006	DECIMAL OF AN INCH AND OF A FOOT
280001-04	TEMPORARY EROSION CONTROL SYSTEMS
442201-03	CLASS C AND D PATCHES
542301-02	PRECAST REINFORCED CONCRETE FLARED END SECTION
701006-03	OFF ROAD OPERATIONS, 2L, 2W 15' TO 24" FROM EDGE OF PAVEMENT
701201-03	LANE CLOSURE, 2L, 2W, DAY ONLY, ON-ROAD TO 600mm (24") OFF-ROAD FOR SPEED ≥45MPH
701301-03	LANE CLOSURE, 2L, 2W, SHORT TIME OPERATIONS
701306-02	LANE CLOSURE, 2L, 2W, SLOW MOVING OPERATIONS - FOR SPEEDS ≥ 45 MPH
701311-03	LANE CLOSURE, 2L, 2W, MOVING OPERATIONS - DAY ONLY
701501-05	URBAN LANE CLOSURE, 2L, 2W UNDIVIDED
701901-01	TRAFFIC CONTROL DEVICES
780001-02	TYPICAL PAVEMENT MARKINGS

FILE NAME :	USER NAME : craige	DESIGNED -	REVISED -	<b>STATE OF ILLINOIS DEPARTMENT OF TRANSPORTATION</b>	<b>INDEX OF SHEETS/STANDARDS</b>	F.A.S. RTE:	SECTION	COUNTY	TOTAL SHEETS	SHEET NO.
c:\pwork\puidot\craige\d0112235\0570511.sht:gennote.dgn	DRAWN -	REVISED -	1476			(55,56)RS-3	McLean	24	2	
PLOT SCALE : 48.0000 / IN.	CHECKED -	REVISED -	CONTRACT NO. 70511							
PLOT DATE : 1/29/2009	DATE -	REVISED -	ILLINOIS FED. AID PROJECT							
SCALE:						SHEET NO.	OF	SHEETS	STA.	TO STA.

# GENERAL NOTES

G.N.-100  
ENGLISH UNITS OF MEASUREMENT SHALL GOVERN OVER AND SUPERSEDE ANY METRIC UNITS SHOWN IN THIS CONTRACT. WHERE INCLUDED, METRIC UNITS ARE FOR INFORMATION ONLY.

G.N.-406  
THE QUANTITIES INCLUDED IN THE PLANS FOR HOT-MIX ASPHALT RESURFACING ARE INTENDED TO GIVE THE COVERAGE SHOWN ON THE TYPICAL CROSS SECTIONS. IT IS NOT INTENDED TO INCREASE THE THICKNESS OF THE HOT-MIX ASPHALT MIXTURE IN ORDER TO USE ALL OF THE QUANTITIES INCLUDED IN THE CONTRACT.

G.N. -406H

### MIXTURE REQUIREMENTS

The following mixture requirements are applicable for this project:

Location	Old US 51	Old US 51	Old US 51
Mixture Use	Class D Patch	Level Binder & LB Special	Surface & Incidental
AC/PG	PG 64-22	PG 64-22	PG 64-22
RAP % (Max)	25	25	15
Design Air Voids	4.0% @ Ndes=50	4.0% @ Ndes=50	4.0% @ Ndes=50
Mix Comp(Gradation)	IL 19.0	IL 9.5	IL 9.5
Friction Aggregate	N.A.	Mix C	Mix C

G.N.-406.05b  
ALL LEVELING BINDER OR BINDER SH  
ALL BE GIVEN A FOG COAT OF PRIME BEFORE THE SURFACE COURSE IS PLACED WHEN DIRECTED BY THE ENGINEER.

THE FOG COAT WILL BE PAID FOR AT THE CONTRACT UNIT PRICE PER GALLON FOR BITUMINOUS MATERIAL (PRIME COAT) AND NO ADDITIONAL COMPENSATION WILL BE ALLOWED.

G.N.-442B -- PATCHING SCHEDULES  
THE PATCHING SCHEDULES INCLUDED IN THE PLANS REPRESENT THE BEST INFORMATION AVAILABLE AT THE TIME OF COMPLETION OF THE PLANS FOR LETTING. VARIATIONS IN LOCATION AND SIZES OF BOTH FULL-DEPTH AND PARTIAL-DEPTH PATCHES MAY OCCUR.

G.N.-540  
THE CONTRACTOR SHALL ASSEMBLE AND MATCH-MARK THE PRECAST BOX CULVERT SECTIONS AND END SECTIONS PRIOR TO SHIPMENT OF THESE COMPONENTS FROM THE MANUFACTURER, AND AS DIRECTED BY THE ENGINEER IN ORDER TO SECURE A PROPER FIT ON EACH JOINT. ANY SECTIONS OR END SECTIONS WHICH DO NOT PROVIDE A PROPER FIT AT THE JOINT SHALL BE REJECTED BY THE ENGINEER AND REPLACED BY THE CONTRACTOR WITH NO ADDITIONAL COMPENSATION BEING ALLOWED.

THIS WORK WILL NOT BE PAID FOR SEPARATELY, BUT SHALL BE INCLUDED IN THE CONTRACT UNIT PRICE PER FOOT FOR PRECAST CONCRETE BOX CULVERTS OF THE SIZE SPECIFIED.

G.N.-540 SPECIAL  
ANY EARTHWORK NECESSARY TO INSTALL THE PROPOSED AR CULVERTS ABOVE AND BEYOND WHAT IS NECESSARY FOR THE REMOVAL OF THE OLD CULVERTS SHALL BE CONSIDERED AS INCIDENTAL TO VARIOUS CULVERT PAY ITEMS AND NO ADDITIONAL COMPENSATION WILL BE ALLOWED. FURTHERMORE, THE CONTRACTOR SHALL PLACE TEMPORARY EROSION CONTROL SEEDING AT ANY LOCATION DISTURBED DURING THE CULVERT WORK AS DESCRIBED IN ARTICLE 280.04(F) AND AS DIRECTED BY THE ENGINEER. THIS TEMPORARY SEEDING SHALL BE CONSIDERED AS INCIDENTAL TO THE VARIOUS CULVERT PAY ITEMS AND NO ADDITIONAL COMPENSATION WILL BE ALLOWED.

G.N.-542  
BEFORE ORDERING PIPE CULVERTS, THE CONTRACTOR SHALL CONSULT THE ENGINEER FOR THE EXACT LENGTHS.

G.N.-542.07  
AT LOCATIONS WHERE END SECTIONS ARE SPECIFIED, CAST-IN-PLACE CONCRETE HEADWALLS WILL NOT BE ALLOWED

G.N.-703A  
SHORT TERM PAVEMENT MARKING SHALL BE APPLIED TO THE PAVEMENT AFTER ANY OF THE FOLLOWING: COLD MILLING AND/OR PLACING BITUMINOUS MATERIALS (PRIME COAT), LEVELING BINDER (MACHINE METHOD), BINDER AND SURFACE COURSES. SHORT TERM PAVEMENT MARKING PLACED ON THE SURFACE, SHALL COINCIDE WITH THE FINAL PAVEMENT STRIPING. SHORT TERM PAVEMENT MARKING PLACED PRIOR TO THE SURFACE SHALL COINCIDE WITH THE EXISTING PAVEMENT MARKINGS. USE 4 FEET PER 40 FEET (OR 10% PER STATION).

G.N.-781  
RAISED REFLECTIVE PAVEMENT MARKERS SHALL BE PLACED IN ACCORDANCE WITH STANDARD 781001, AND THE DETAILS SHOWN IN THE PLANS. IF THERE IS ANY DISCREPANCY BETWEEN THE STANDARD AND THE DETAILS IN THE PLANS, THE DETAILS IN THE PLANS SHALL GOVERN. THE FINAL PAVEMENT MARKINGS SHALL BE IN PLACE PRIOR TO PLACING THE RAISED REFLECTIVE PAVEMENT MARKERS AND THE RAISED REFLECTIVE PAVEMENT MARKERS SHALL BE PLACED MIDWAY IN THE 30 FOOT (9 m) SPACE BETWEEN THE DASHED CENTERLINE STRIPES (WHEN APPLICABLE).

G.N.-1004.01  
COARSE AGGREGATE GRADATION CA-10 MAY BE USED WHENEVER COARSE AGGREGATE CA-6 IS SPECIFIED IN THE STANDARD SPECIFICATIONS.

### NO COMMITMENTS

FILE NAME =	USER NAME = craige	DESIGNED -	REVISED -	<b>STATE OF ILLINOIS DEPARTMENT OF TRANSPORTATION</b>	<b>GENERAL NOTES</b>	F.A.S. RTE:	SECTION	COUNTY	TOTAL SHEETS	SHEET NO.	
c:\pwwork\pwwork\craige\0112235\0578511-sh1-gennotes.dgn	DRAWN -	REVISED -	1476			(55,56)RS-3	McLean	24	3		
PLOT SCALE = 48.0000 / IN.	CHECKED -	REVISED -	CONTRACT NO. 70511								
PLOT DATE = 1/29/2009	DATE -	REVISED -	ILLINOIS FED. AID PROJECT								
						SCALE:	SHEET NO.	OF	SHEETS	STA.	TO STA.

# SUMMARY OF QUANTITIES

RURAL  
100% STATE  
OLD US51

CODE NO.	ITEM	UNIT	TOTAL QUANTITY
			1000
20800150	TRENCH BACKFILL	CU YD	12
28000500	INLET AND PIPE PROTECTION	EACH	2
40600100	BITUMINOUS MATERIALS (PRIME COAT)	GALLON	8,914
40600300	AGGREGATE (PRIME COAT)	TON	180
40600625	LEVELING BINDER (MACHINE METHOD), N50	TON	4,528
40600895	CONSTRUCTING TEST STRIP	EACH	1
40600982	HOT-MIX ASPHALT SURFACE REMOVAL- BUTT JOINT	SQ YD	3,055
40600985	PORTLAND CEMENT CONCRETE SURFACE REMOVAL-BUTT JOINT	SQ YD	40
40600990	TEMPORARY RAMP	SQ YD	220
40603310	HOT-MIX ASPHALT SURFACE COURSE, MIX C, N50	TON	10,052
40800010	BITUMINOUS MATERIALS (PRIME COAT)	GAL	300
40800030	AGGREGATE (PRIME COAT)	TON	6
40800050	INCIDENTAL HOT-MIX ASPHALT SURFACING	TON	558
44000155	HOT-MIX ASPHALT SURFACE REMOVAL, 1 1/2"	SQ YD	12,531
44000196	HOT-MIX ASPHALT SURFACE REMOVAL, SPECIAL	SQ YD	4,083
44201803	CLASS D PATCHES, TYPE II, 13 INCH	SQ YD	174
44201807	CLASS D PATCHES, TYPE III, 13 INCH	SQ YD	85
44201809	CLASS D PATCHES, TYPE IV, 13 INCH	SQ YD	220
48101200	AGGREGATE SHOULDERS, TYPE B	TON	1,320
50105220	PIPE CULVERT REMOVAL	FOOT	80
54020302	PRECAST CONCRETE BOX CULVERT 3'x2' (m213)	FOOT	40
54200445	PIPE CULVERTS, TYPE 1 RCCP 30"	FOOT	40
54213675	PRECAST REINFORCED CONCRETE FLARED END SECTIONS 30"	EACH	2
67100100	MOBILIZATION	L SUM	1
70100450	TRAFFIC CONTROL AND PROTECTION, STANDARD 701201	L SUM	1
70100460	TRAFFIC CONTROL AND PROTECTION, STANDARD 701306	L SUM	1
70102620	TRAFFIC CONTROL AND PROTECTION, STANDARD 701501	L SUM	1
70300100	SHORT-TERM PAVEMENT MARKING	FOOT	11,850
70300625	TEMPORARY PAINT PAVEMENT MARKING LINE 4"	FOOT	88,599
70301000	WORK ZONE PAVEMENT MARKING REMOVAL	SQ FT	1,306
* 78001110	PAINT PAVEMENT MARKING - LINE 4"	FOOT	88,599
X0914100	PRECAST CONCRETE BOX CULVERT END SECTIONS 3'x2'	EACH	2
XX007274	LEVELING BINDER (MACHINE METHOD) SPECIAL	TON	457

\* SPECIALTY ITEMS

FILE NAME :	USER NAME : craige	DESIGNED -	REVISED -	STATE OF ILLINOIS DEPARTMENT OF TRANSPORTATION	SUMMARY OF QUANTITIES	F.A.S. RTE.	SECTION	COUNTY	TOTAL SHEETS	SHEET NO.	
ct:\pr_work\pvd\dot\craige-d0112235-10570801-sh1-500.dgn		DRAWN -	REVISED -			1476	(55,56)RS-3	McLean	24	4	
PLOT SCALE : 48,0000' / IN.		CHECKED -	REVISED -								
PLOT DATE : 1/29/2009		DATE -	REVISED -								
						SCALE:		SHEET NO. OF SHEETS STA.		TO STA.	
						ILLINOIS FED. AID PROJECT CONTRACT NO. 70511					

# TYPICAL SECTIONS

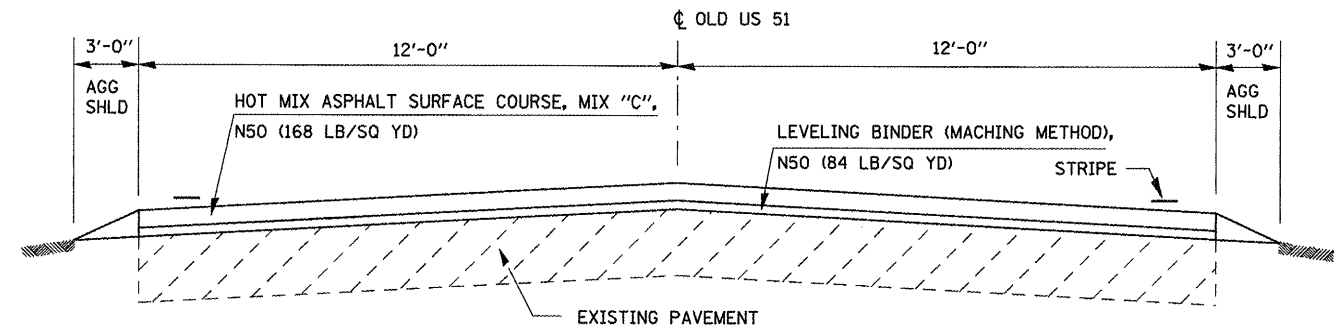

PROPOSED ROADWAY TYP. SECTION ①

(TR 100 N)  
STA. 51+96 TO STA. 54+60 ④

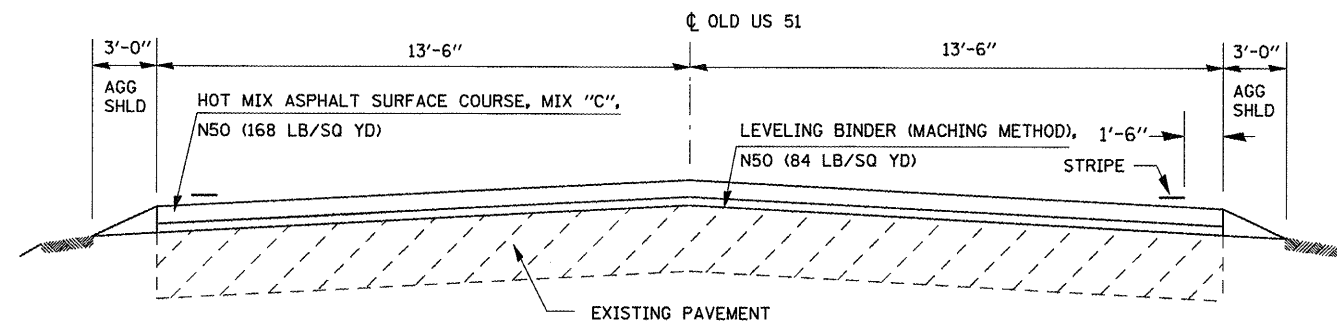

PROPOSED ROADWAY TYP. SECTION ②

(OLD US 51)  
① STA. 54+60 TO STA. 91+56 ②  
③ STA. 182+92.80 TO STA. 437+42.40 ⑤

FILE NAME =	USER NAME = craigre	DESIGNED -	REVISED -
c:\pw\work\pwsdot\craigre\d0112235\05705	1-aht-typical.dgn	DRAWN -	REVISED -
	PLOT SCALE = 48.0000' / IN.	CHECKED -	REVISED -
	PLOT DATE = 1/29/2009	DATE -	REVISED -

**STATE OF ILLINOIS  
DEPARTMENT OF TRANSPORTATION**

<b>TYPICAL SECTIONS</b>			
SCALE:	SHEET NO.	OF SHEETS	STA. TO STA.

F.A.S. RTE.	SECTION	COUNTY	TOTAL SHEETS	SHEET NO.
1476	(55,56)RS-3	McLean	24	5
CONTRACT NO. 70511				
ILLINOIS FED. AID PROJECT				

# TYPICAL SECTIONS

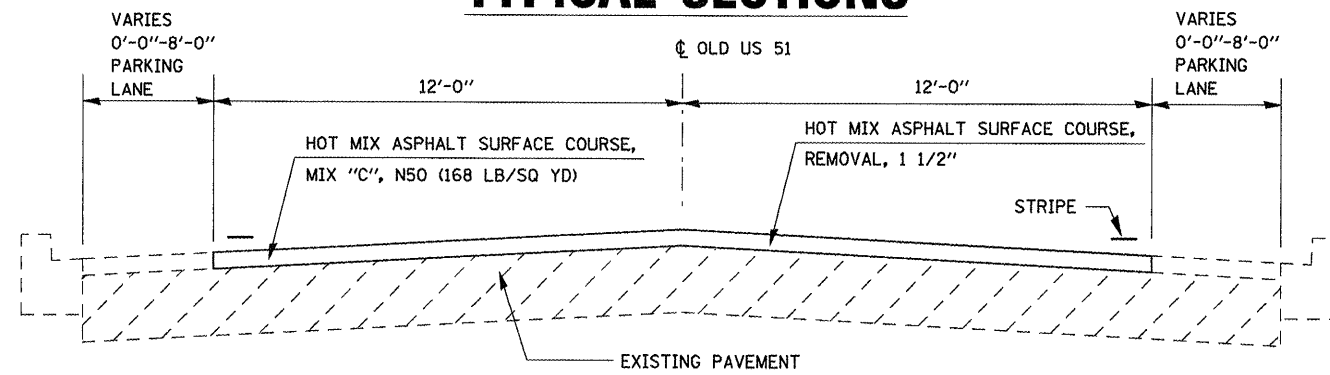

## PROPOSED ROADWAY TYP. SECTION ③

(OLD US 51)

④ STA. 91+56 TO STA. 106+00  
 STA. 108+00 TO STA. 138+05 ③

OMISSION (US 136 AND OLD US 51 INTERSECTION) STA. 106+00 TO STA. 108+00

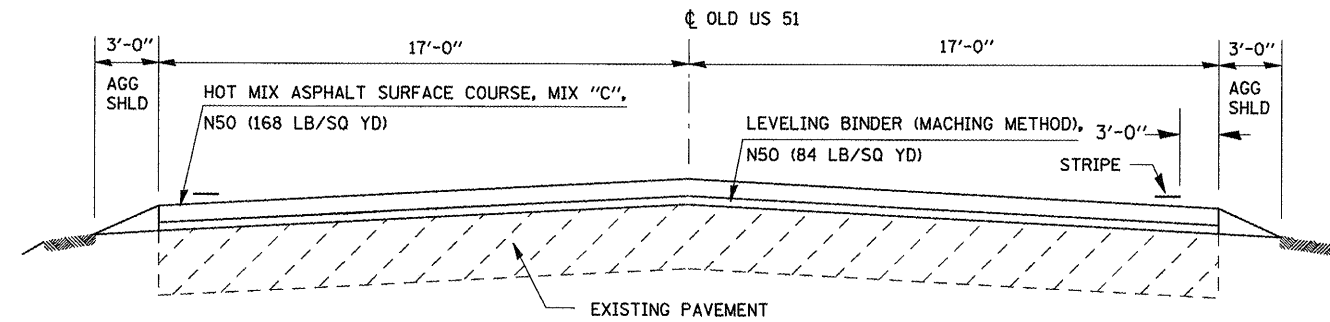

## PROPOSED ROADWAY TYP. SECTION ④

(OLD US 51)

② STA. 138+05 TO STA. 182+92.80 ④

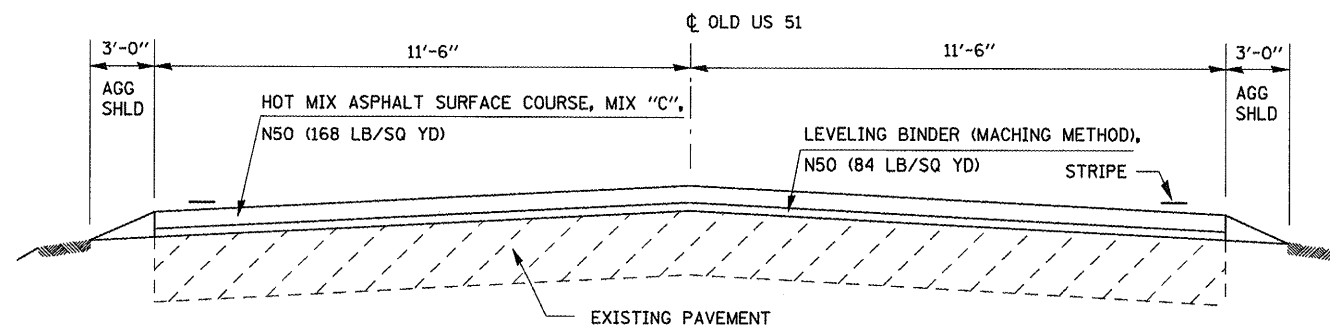

## PROPOSED ROADWAY TYP. SECTION ⑤

(TR 800)

④ STA. 437+42.40 TO STA. 446+92.80

FILE NAME =	USER NAME = orasgr
at\pwork\pwork\orasgr\d0112235\05705	l-shht-typico1.dgn
PLOT SCALE = 1/8" = 1'-0"	
PLOT DATE = 1/29/2009	

DESIGNED -	REVISD -
DRAWN -	REVISD -
CHECKED -	REVISD -
DATE -	REVISD -

STATE OF ILLINOIS
DEPARTMENT OF TRANSPORTATION

TYPICAL SECTIONS			
SCALE:	SHEET NO. OF SHEETS	STA.	TO STA.

F.A.S. RTE.	SECTION	COUNTY	TOTAL SHEETS	SHEET NO.
1476	(55,56)RS-3	McLean	24	6
CONTRACT NO. 70511				
ILLINOIS FED. AID PROJECT				

# LOCATION MAP

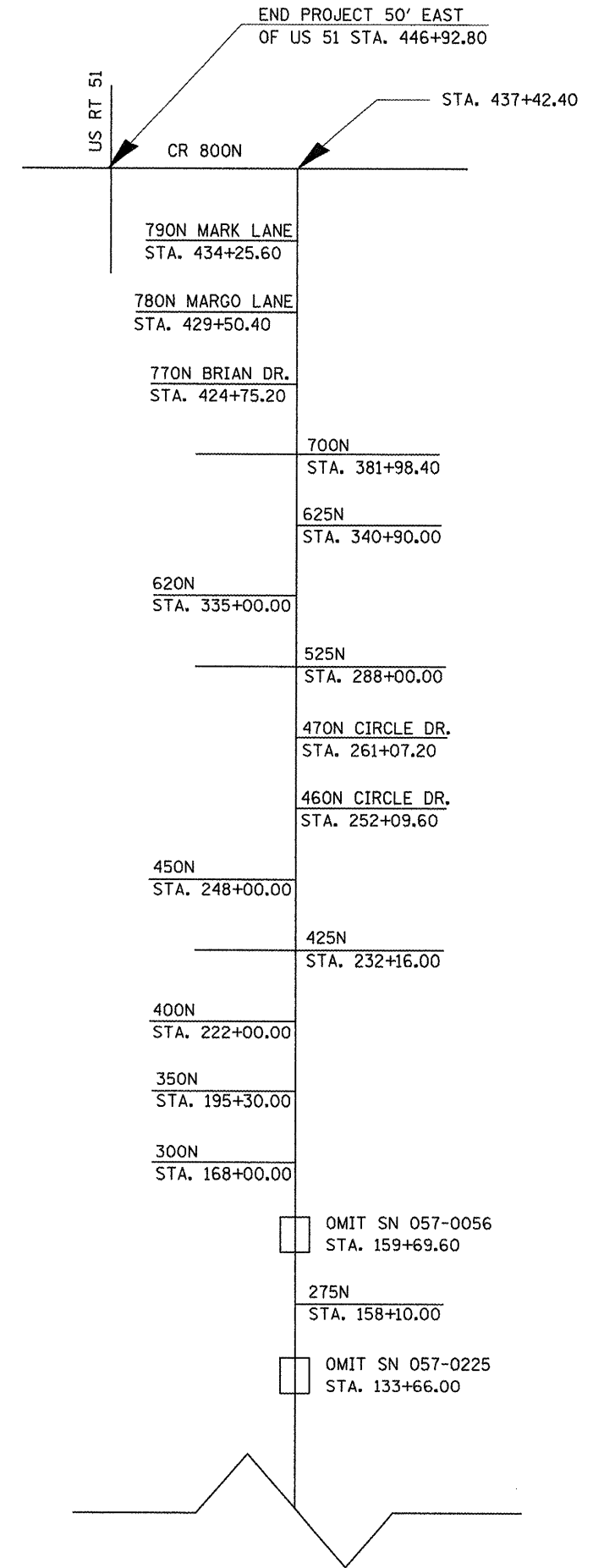
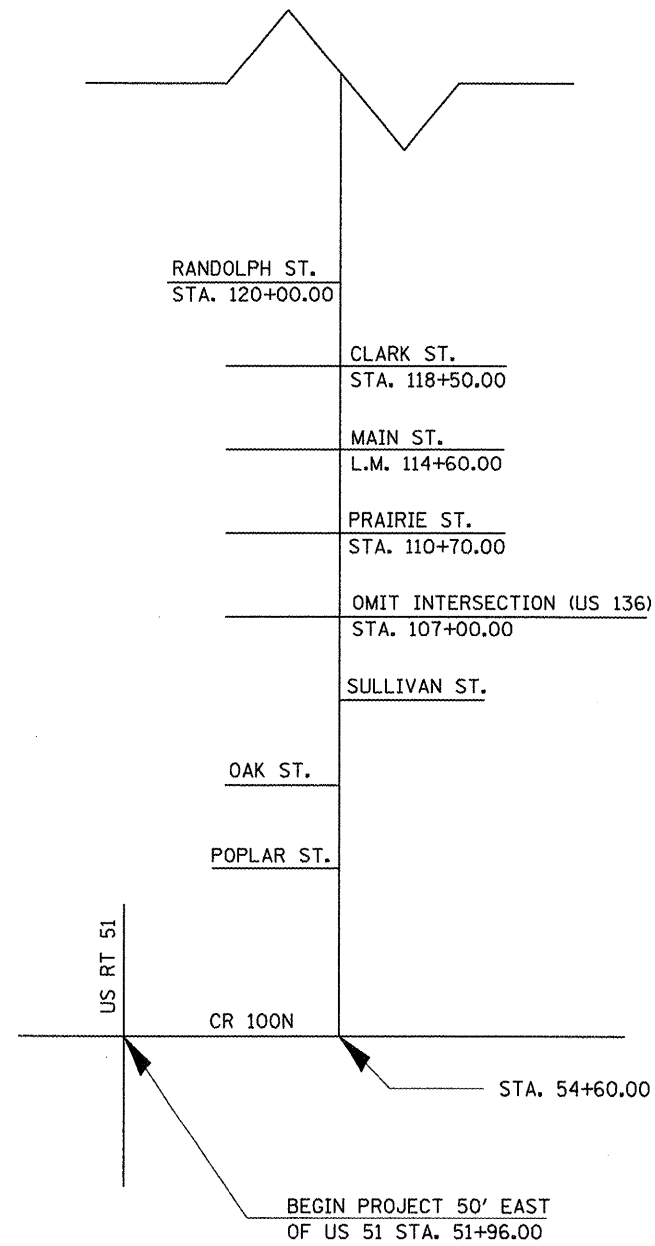

FILE NAME =	USER NAME = craigre	DESIGNED -	REVISED -
c:\pwork\pwork\craigre\d0112235\05705	11-shr-ATB.dgn	DRAWN -	REVISED -
	PLOT SCALE = 48.0000 "/>	CHECKED -	REVISED -
	PLOT DATE = 1/29/2009	DATE -	REVISED -

**STATE OF ILLINOIS  
DEPARTMENT OF TRANSPORTATION**

<b>LOCATION MAP</b>	
SCALE:	SHEET NO. OF SHEETS STA. TO STA.

F.A.S. RTE.	SECTION	COUNTY	TOTAL SHEETS	SHEET NO.
1476	(55,56)RS-3	McLean	24	7
CONTRACT NO. 70511			ILLINOIS FED. AID PROJECT	

# SCHEDULES

MAINLINE									
STATION	LENGTH	AREA	LEVELING BINDER (MM) N50	AGGREGATE PRIME COAT	HMA SURFACE REMOVAL 1 1/2"	TEMPORARY RAMP	BIT MATL PRIME COAT	HMA SURF MIX C. N50	AGGREGATE SHOULDERS
	FT	SQ YD	TON	TON	SQ YD	SQ YD	GAL	TON	TON
51+96 TO 54+60	369	984	41.3	1.5	0.0	13.3	73.8	82.7	13.9
54+60 TO 91+56	3696	11088	465.7	16.6	0.0	0.0	831.6	931.4	138.6
91+56 TO 106+00	1444	3851	0.0	5.8	3851.0	0.0	288.8	323.5	0.0
108+00 TO 138+05	3005	8013	0.0	12.0	8013.0	64.5	551.1	673.1	0.0
138+05 TO 182+92.80	4488	16955	712.1	25.4	0.0	37.8	1280.3	1424.2	168.3
182+92.80 TO 437+42.40	25450	76350	3206.7	114.5	0.0	90.0	5726.3	6413.4	954.4
473+42.40 TO 446+92.80	950	2428	102.0	3.6	0.0	12.8	182.1	204.0	35.6
<b>TOTALS</b>			<b>4528.0</b>	<b>180.0</b>	<b>12531.0</b>	<b>220.0</b>	<b>8914.0</b>	<b>10052.0</b>	<b>1320.0</b>

NOTE: OMIT SN 057-0056 & SN 057-0225  
OMIT US 136 INTERSECTION

PAVEMENT MARKING SCHEDULE					
LOCATION	PAINT PVMT MRK - LINE 4" (WHITE)	PAINT PVMT MRK - LINE 4" (YELLOW)	SHORT TERM PVMT MRK	WORK ZONE PVMT MRK REM	TEMP PVMT MRK - LINE 4"
STATION	FT	FT	FT	SQ FT	FT
STA. 446+92.8 TO STA. 138+05.00	58,292	7,287	9,266	1,021	65,579
STA. 138+05.00 TO STA. 91+56.00	9,504		1,395	154	9,504
STA. 91+56.00 TO STA. 51+96.00	7,392	924	1,189	131	8,316
NO PASSING ZONES		5,200			5,200
<b>TOTAL</b>	<b>75,188</b>	<b>13,411</b>	<b>11,850</b>	<b>1,306</b>	<b>88,599</b>
<b>TOTAL</b>		<b>88,599</b>			

NOTE: THE ENGINEER SHALL VERIFY THE LOCATION OF THE NO PASSING ZONES PRIOR TO CONSTRUCTION  
NOTE: QUANTITIES OUTSIDE THE LIMITS OF THE SECTION ARE INCLUDED IN THE QUANTITIES LISTED.

CLASS D PATCHING						
STATION	LANE	LENGTH (FT)	WIDTH (FT)	TYPE II SQ YD	TYPE III SQ YD	TYPE IV SQ YD
63+70.16	NB	6	14	9.33		
63+70.16	SB	6	14	9.33		
72+20.24	NB	6	14	9.33		
72+20.24	SB	6	14	9.33		
80+86.16	NB	6	14	9.33		
80+86.16	SB	6	14	9.33		
84+98.00	NB	6	14	9.33		
84+98.00	SB	6	14	9.33		
99+86.96	NB	6	12	8.00		
99+86.96	SB	6	12	8.00		
194+09.76	NB	50	10			55.60
203+65.00	NB	4.5	14	7.00		
203+65.00	SB	4.5	14	7.00		
224+80.00	NB	18.2	14			28.30
224+80.00	SB	18.2	14			28.30
264+74.80	NB	6	14	9.33		
264+74.80	SB	6	14	9.33		
339+46.00	SB	4	14	6.22		
347+22.16	SB	8	14	12.44		
347+59.12	SB	20	14			31.11
353+29.36	SB	20	14			31.11
354+93.04	SB	6	10	6.67		
354+98.32	SB	6	10	6.67		
357+94.00	SB	20	10		22.22	
388+30.00	NB	10	14		15.56	
388+30.00	SB	10	14		15.56	
408+36.40	SB	40	10			44.44
416+49.52	SB	6	14	9.33		
416+91.76	NB	10	14		15.56	
418+66.00	SB	10	14		15.56	
428+10.48	SB	6	14	9.33		
<b>TOTALS (SQ YD)</b>				<b>174.0</b>	<b>85.0</b>	<b>220.0</b>



# SCHEDULES

SIDEROAD AND ENTRANCE SCHEDULE						
LOCATION	DESCRIPTION	TOTAL AREA	HMA SURFACE REMOVAL (BUTT JOINT)	PCC SURFACE REMOVAL (BUTT JOINT)	HMA SURFACE REMOVAL 1-1/2"	INCIDENTAL HMA SURFACING
STATION		SQ YD	SQ YD	SQ YD	SQ YD	TON
437+42.40	800 N ROAD	100.0				12.6
434+25.60	790 N ROAD (MARK LANE) RT	83.3	44.44			10.5
429+50.40	780 N ROAD (MARGO LANE) RT	83.3	44.44			10.5
424+75.20	770 N ROAD (BRIAN DRIVE) RT	83.3	44.44			10.5
423+69.60	PE LT	22.2		6.67		2.8
423+69.60	MB RT	0.0				1.0
419+47.20	PE LT	22.2				2.8
381+98.40	700 N ROAD RT	150.0	88.89			18.9
381+98.40	700 N ROAD LT	150.0	88.89			18.9
348+19.20	PE RT	18.9				2.4
346+08.00	PE RT	18.9	5.33			2.4
342+91.20	PE RT	22.2	6.67			2.8
340+90.00	625 N ROAD LT	216.7	133.33			27.3
341+32.80	CE LT	44.4				5.6
341+32.80	PE RT	22.2				2.8
335+00.00	620 N ROAD RT	136.7	80.00			17.2
334+99.20	PE RT	22.2				2.8
319+15.20	PE RT	22.2				2.8
311+23.20	PE RT	32.2				4.1
299+08.80	PE RT	27.8				3.5
296+97.60	PE LT	27.8				3.5
288+00.00	525 N ROAD RT	96.7				12.2
288+00.00	525 N ROAD LT	96.7				12.2
286+41.60	PE LT	18.9				2.4
277+96.80	PE LT	22.2				2.8
273+74.40	PE LT	22.2	6.67			2.8
271+63.20	PE RT	18.9				2.4
271+10.40	PE LT	32.2				4.1
261+07.20	470 N ROAD (CIRCLE DRIVE) LT	83.3	44.44			10.5
256+32.00	PE RT	22.2				2.8
255+79.20	PE LT	18.9				2.4
254+73.60	PE LT	18.9				2.4
252+09.60	460 N ROAD (CIRCLE DRIVE) LT	83.3	44.44			10.5
249+98.40	PE LT	18.9				2.4
248+00.00	450 N ROAD RT	83.3				10.5
247+47.20	PE LT	27.8	8.89			3.5
247+42.20	ME LT	0.0				1.0
244+30.40	PE LT	22.2	6.67			2.8
240+60.80	PE LT	32.2	10.67			4.1
240+08.00	PE LT	22.2	6.67			2.8
234+80.00	PE RT	18.9	5.33			2.4
233+74.40	PE LT	22.2	6.67			2.8
233+21.60	SIDE ROAD RT	27.8	8.89			3.5
232+16.00	425 N ROAD RT	83.3				10.5
232+16.00	425 N ROAD LT	83.3				10.5
232+16.00	PE RT	22.2				2.8
225+69.60	PE RT	22.2				2.8
223+05.60	PE RT	18.9				2.4
222+00.00	400N ROAD RT	83.3				10.5
<b>PAGE TOTALS</b>		2430.0	685.8	6.7	0.0	308.2

# SCHEDULES

SIDEROAD AND ENTRANCE SCHEDULE						
LOCATION	DESCRIPTION	TOTAL AREA	HMA SURFACE REMOVAL (BUTT JOINT)	PCC SURFACE REMOVAL (BUTT JOINT)	HMA SURFACE REMOVAL 1-1/2"	INCIDENTAL HMA SURFACING
STATION		SQ YD	SQ YD	SQ YD	SQ YD	TON
221+70.00	PE LT	18.9				2.4
219+06.00	CE LT	44.4		15.56		5.6
211+14.00	CE LT	50.0		17.78		6.3
200+58.00	PE RT	22.2				2.8
195+30.00	350 N ROAD RT	83.3				10.5
187+38.00	PE LT	18.9				2.4
187+38.00	PE RT	22.2	6.67			2.8
184+74.00	PE RT	18.9	5.33			2.4
184+74.00	PE LT	18.9	5.33			2.4
168+00.00	300 N ROAD RT	96.7	53.33			12.2
158+10.00	275 N ROAD LT	83.3				10.5
150+18.00	CE RT	94.4				11.9
147+54.00	MB RT	0.0				1.0
147+01.20	PE LT	22.2				2.8
136+98.00	CE LT	44.4				5.6
129+06.00	PE LT	18.9				2.4
128+53.20	PE LT	18.9				2.4
120+00.00	RANDOLPH ST RT	83.3			83.33	10.5
118+50.00	CLARK ST RT	116.7			116.67	14.7
118+50.00	CLARK ST LT	116.7			116.67	14.7
114+60.00	MAIN ST RT	116.7			116.67	14.7
114+60.00	MAIN ST LT	116.7			116.67	14.7
110+70.00	PRAIRIE ST.	116.7			116.67	14.7
89+78.40	SIDE ROAD LT	116.7				14.7
89+78.40	CE RT	32.2				4.1
88+20.00	CE RT	44.4				5.6
87+14.40	CE LT	44.4				5.6
		0.0				0.0
	SUB-TOTALS -	4,011.10	756.4	40.0	666.70	558.0
	TOTALS (INCLUDING MAINLINE) -	118,853.0	3,055.0	40.0	12,531.0	558.0

HMA SURFACE REMOVAL (SPECIAL)			
LOCATION	HMA SURF REM(SP)	LEVELING BINDER (MM) SPECIAL	BIT MAT'L (PR CT)
	SQ YD	TON	GAL
STA. 341+85.60 TO	4,083	457	306
STA. 433+72.80 (NBL)			

AR CULVERTS			
STATION	DESCRIPTION	LENGTH *	END TREATMENT
203+65	PIPE CULVERT, TY 1, RCCP 30"	40 FT	PRC FLARED END SECTION 30 - 2 EACH
224+80	PCBC, 3X2 (M273)	40 FT	PCBC END SECTION 3X2 - 2 EACH

**NOTES**

THESE CULVERTS SHALL BE INSTALLED TO MEET THE FLOWLINES OF THE EXISTING DRAINAGE SYSTEM

\* AS ALSO DESCRIBED IN THE GENERAL NOTES, THE CONTRACTOR SHALL CONSULT THE ENGINEER TO DETERMINE THE EXACT LENGTHS OF THE CULVERTS

# DETAILS

## HMA SURFACE REM. (SP) & LEVELING BIND. (MM) (SP)

LOOKING NORTH  
STA. 341+85.60 TO STA. 433+72.80

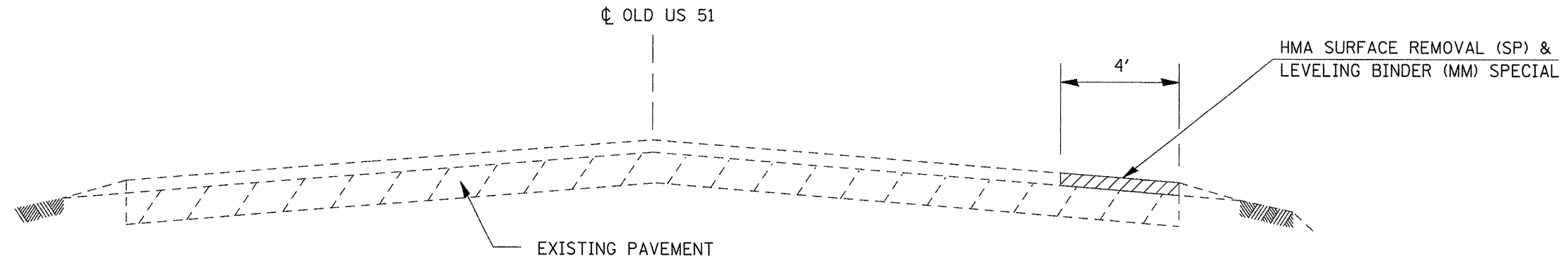

## HMA SURFACE REMOVAL (RUNDOWN)

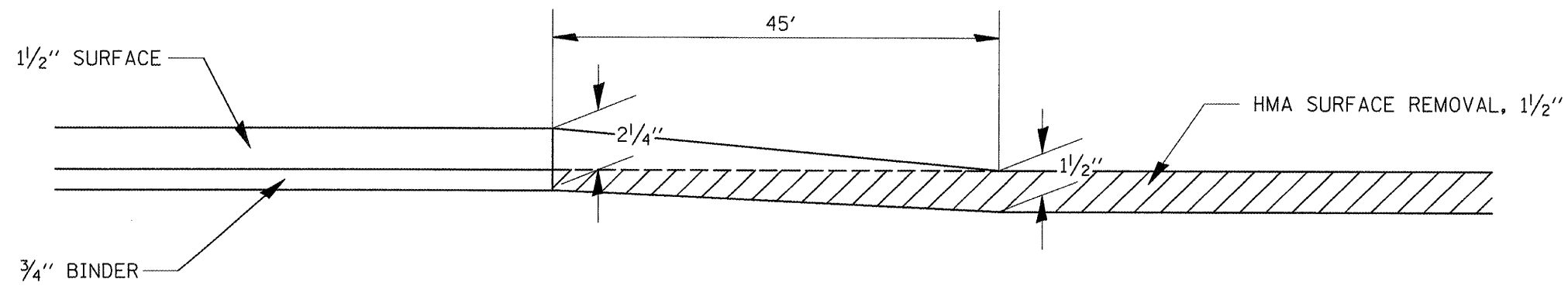

## HMA SURFACE REMOVAL (BUTT JOINT)

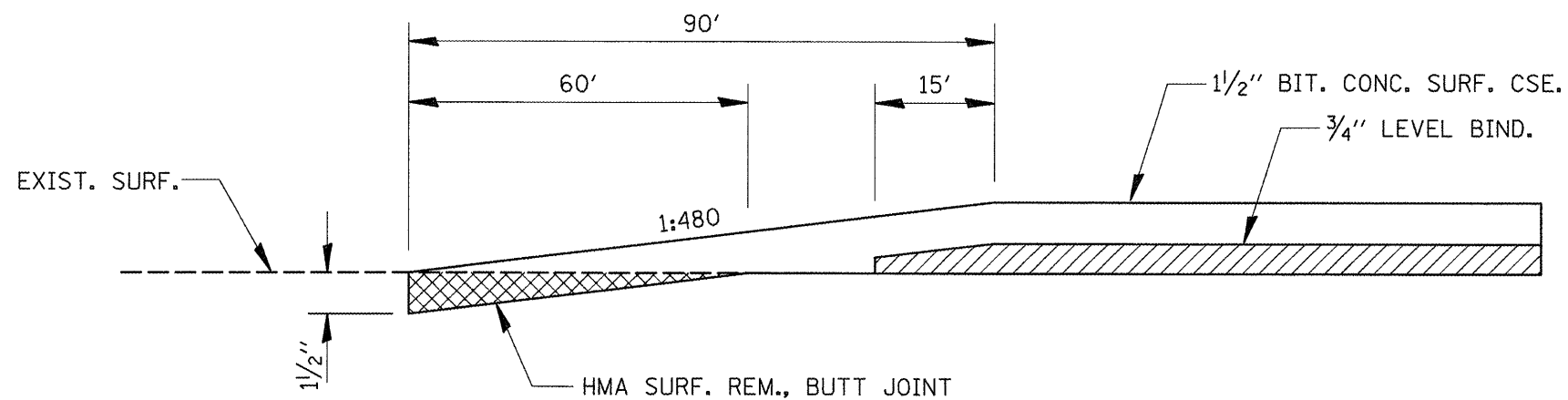

### HMA SURFACE REMOVAL (BUTT JOINT) LOCATIONS

- STA. 51+96.00 - 1 BUTT JOINT
- STA. 133+66.00 - 2 BUTT JOINTS
- STA. 159+69.60 - 2 BUTT JOINTS
- STA. 271+24.00 - 2 BUTT JOINTS
- STA. 289+80.00 - 2 BUTT JOINTS
- STA. 309+25.00 - 2 BUTT JOINTS
- STA. 446+92.80 - 1 BUTT JOINT

FILE NAME =	USER NAME = craigre	DESIGNED -	REVISED -	<b>STATE OF ILLINOIS DEPARTMENT OF TRANSPORTATION</b>	<b>DETAILS</b>	F.A.S. RTE.	SECTION	COUNTY	TOTAL SHEETS	SHEET NO.	
ca\pwork\pwork\CRAIGRE\d0112235\0570	11-sht-details.dgn	DRAWN -	REVISED -			1476	(55,56)RS-3	McLean	24	11	
PLOT SCALE = 48.0000' / IN.	CHECKED -	REVISED -	REVISED -			CONTRACT NO. 70511			ILLINOIS FED. AID PROJECT		
PLOT DATE = 2/3/2009	DATE -	REVISED -	REVISED -			SCALE:	SHEET NO.	OF SHEETS	STA.	TO STA.	

## PROJECTS WITHOUT RECONSTRUCTION

**S.M.A.R.T. IMPROVEMENTS**  
(POLICY RESURFACING; BDE 53-4.03; 1/2")

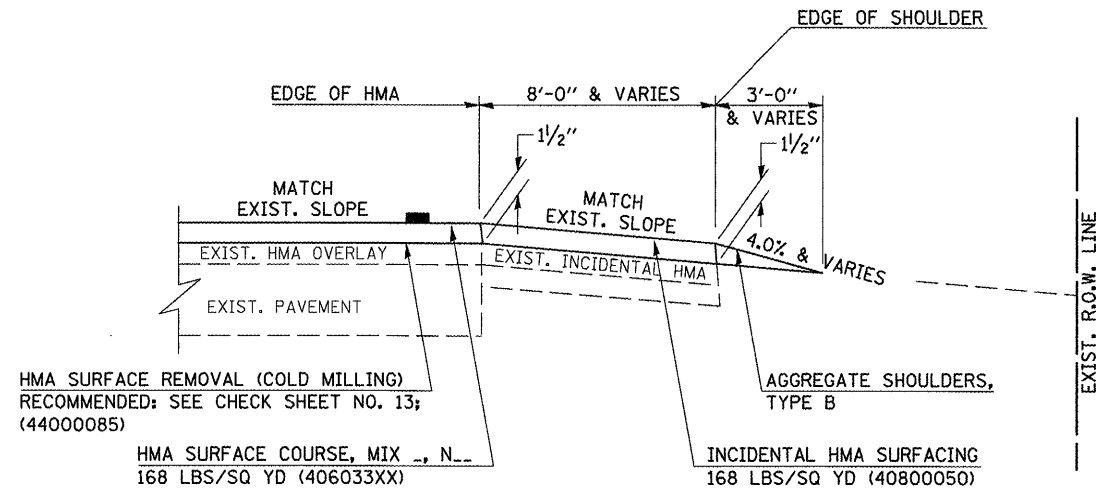

**"3P" OR "3R" IMPROVEMENTS**  
(POLICY RESURFACING; BDE 53-4.02; 2/4" OR 2/2" ON BARE CONCRETE)

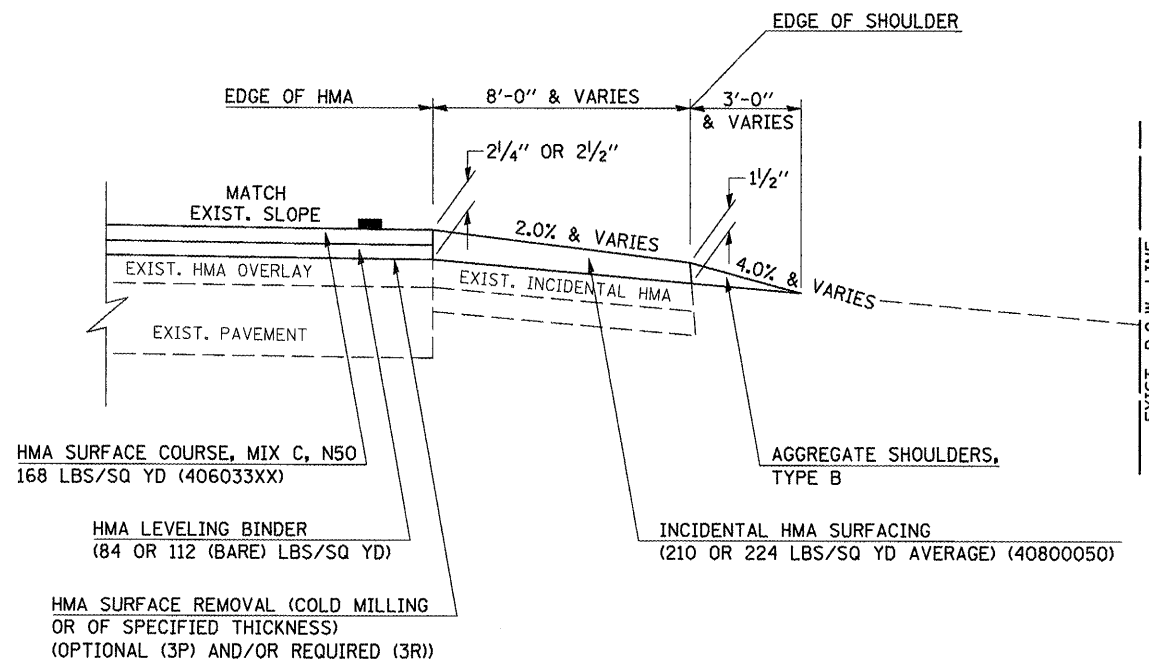

### GENERAL NOTES

1. THE EXISTING SURFACE SHALL BE PREPARED IN ACCORDANCE WITH SECTION 408 OF THE STANDARD SPECIFICATIONS.
2. AGGREGATE BASE COURSE, TYPE B, 6" (150) MIN. SHALL BE USED WHERE IN THE OPINION OF THE ENGINEER THERE IS NOT SUFFICIENT BASE MATERIAL FOR THE PROPOSED MAILBOX TURNOUTS. THIS MATERIAL SHALL GENERALLY BE USED TO WIDEN ALL EXISTING MAILBOX TURNOUTS OR TO CONSTRUCT NEW MAILBOX TURNOUTS WHERE NONE NOW EXISTS.
3. ANY NECESSARY WORK BEHIND THE INCIDENTAL HMA SURFACING SHALL BE AS SHOWN IN THE PLANS AND/OR AS DIRECTED BY THE ENGINEER.
4. THE TEMPORARY RELOCATION OF EXISTING MAILBOXES SHALL BE IN ACCORDANCE WITH ARTICLE 107.20 OF THE STANDARD SPECIFICATIONS.
5. WHEN MORE THAN ONE RELOCATED MAILBOX IS INCLUDED IN A PARTICULAR LOCATION THE TWO 10' (3 m) DIMENSIONS AS SHOWN ABOVE SHALL BE FROM THE END MAILBOX.
6. CROSS SLOPE SHALL BE AS SHOWN ON THE STATION CROSS SECTIONS AND/OR AS DIRECTED BY THE ENGINEER.  
MINIMUM 4% (1/2"/') DESIRABLE; MAXIMUM 8% (1"/')
7. WHEN MAILBOX TURNOUTS ARE CONSTRUCTED ADJACENT TO FIELD ENTRANCES, THE WIDTH OF THE INCIDENTAL HMA SURFACING CONSTRUCTED FOR THE FIELD ENTRANCE SHALL MATCH THE WIDTH OF THE PROPOSED MAILBOX TURNOUT SURFACING.
8. THE TOTAL SHOULDER WIDTH, 2.4 m (8') MINIMUM, SHALL BE PAVED BETWEEN SIDEROADS ENTRANCES AND/OR MAILBOX TURNOUTS AT LOCATIONS WHERE THE DISTANCE BETWEEN RADIUS OR TAPER CONTROL POINTS IS LESS THAN 15.0 m (50').
9. MAILBOXES SHALL BE MOUNTED SUCH THAT THE FACE OF THE MAILBOX IS 6" (150 mm) TO 12" (300 mm) AND THE POST A MINIMUM OF 24" (600 mm) FROM THE EDGE OF THE TURNOUT SURFACING.

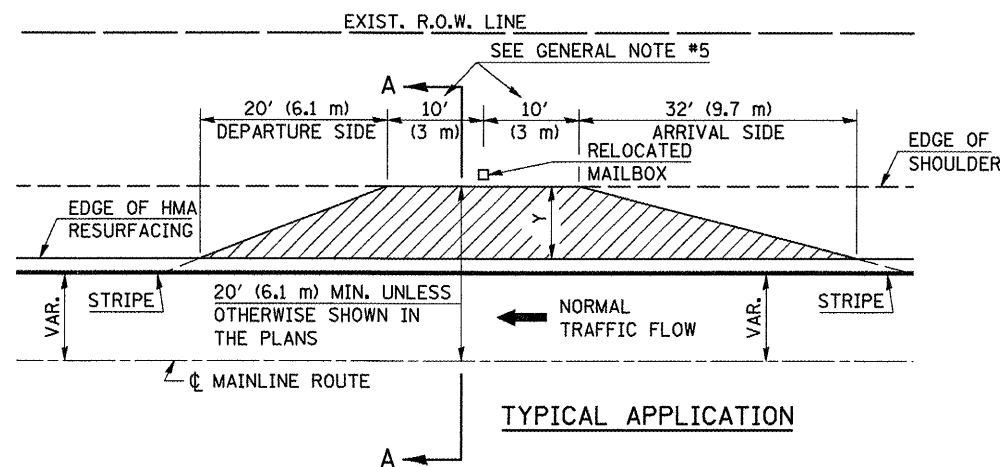

## PROJECTS WITH RECONSTRUCTION

("3R" IMPROVEMENTS)

WIDTH OF SHOULDER	4'-0" - 8'-0" (1.2 m - 2.4 m)	10'-0" (3.0 m)
WIDTH OF TURNOUT "Y"	8'-0" (2.4 m)	8'-0" - 10'-0" (2.4 m - 3.0 m)

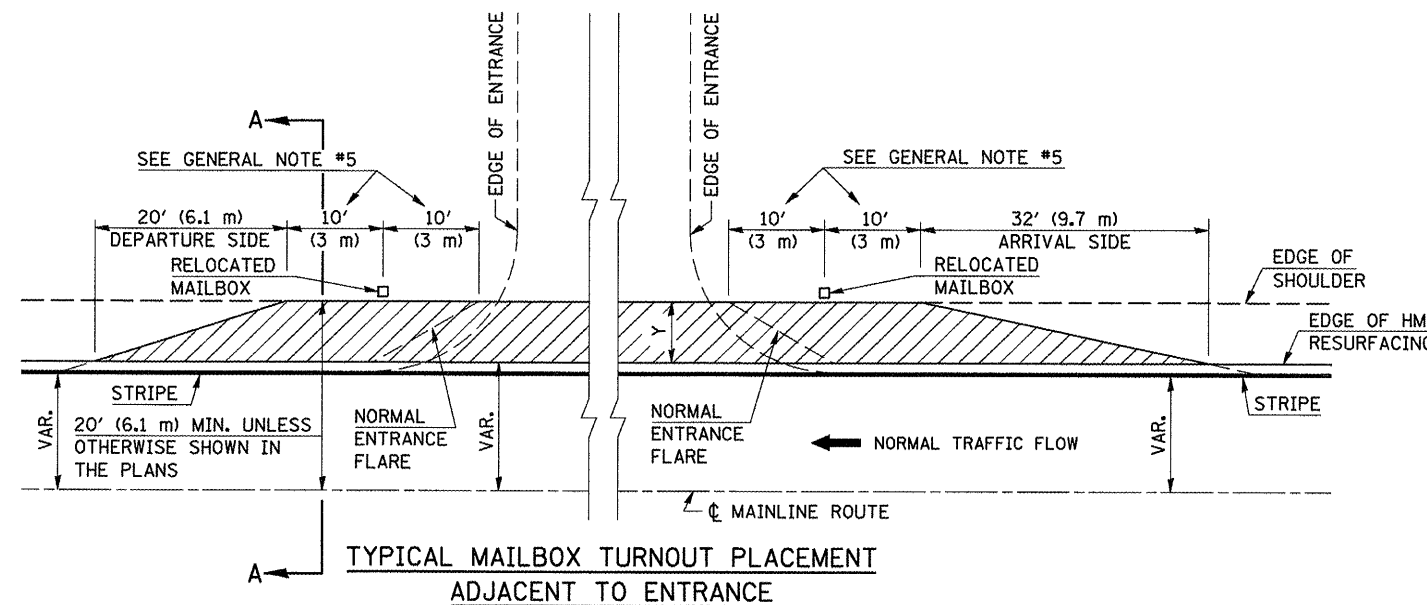
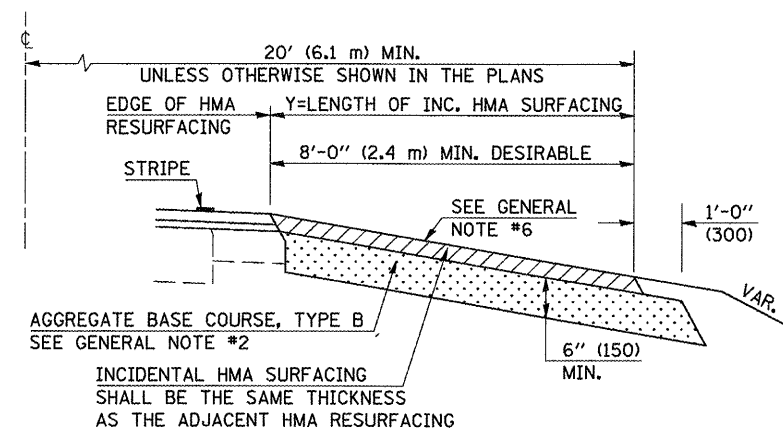

Note: All dimensions are in INCHES  
(millimeters) unless otherwise shown.

FILE NAME =	USER NAME = craig	DESIGNED -	REVISED - 12/11/06 TJB
ct\pwwork\pwwork\craig\112235\05708	1-aht-detail.dgn	DRAWN -	REVISED - 09/21/07 KAG
	PLOT SCALE = 48,0000 "/ IN.	CHECKED -	REVISED -
	PLOT DATE = 1/29/2009	DATE -	REVISED -

**STATE OF ILLINOIS  
DEPARTMENT OF TRANSPORTATION**

**MAILBOX TURNOUT (RURAL)**

SCALE: NA SHEET NO. OF SHEETS STA. TO STA.

<b>DISTRICT 5 DETAIL NO. 40800050B</b>				
F.A.S. RTE.	SECTION	COUNTY	TOTAL SHEETS	SHEET NO.
1476	(55,56)RS-3	McLean	24	12
CONTRACT NO. 70511				
FED. ROAD DIST. NO.		ILLINOIS FED. AID PROJECT		

# PROJECTS WITHOUT RECONSTRUCTION

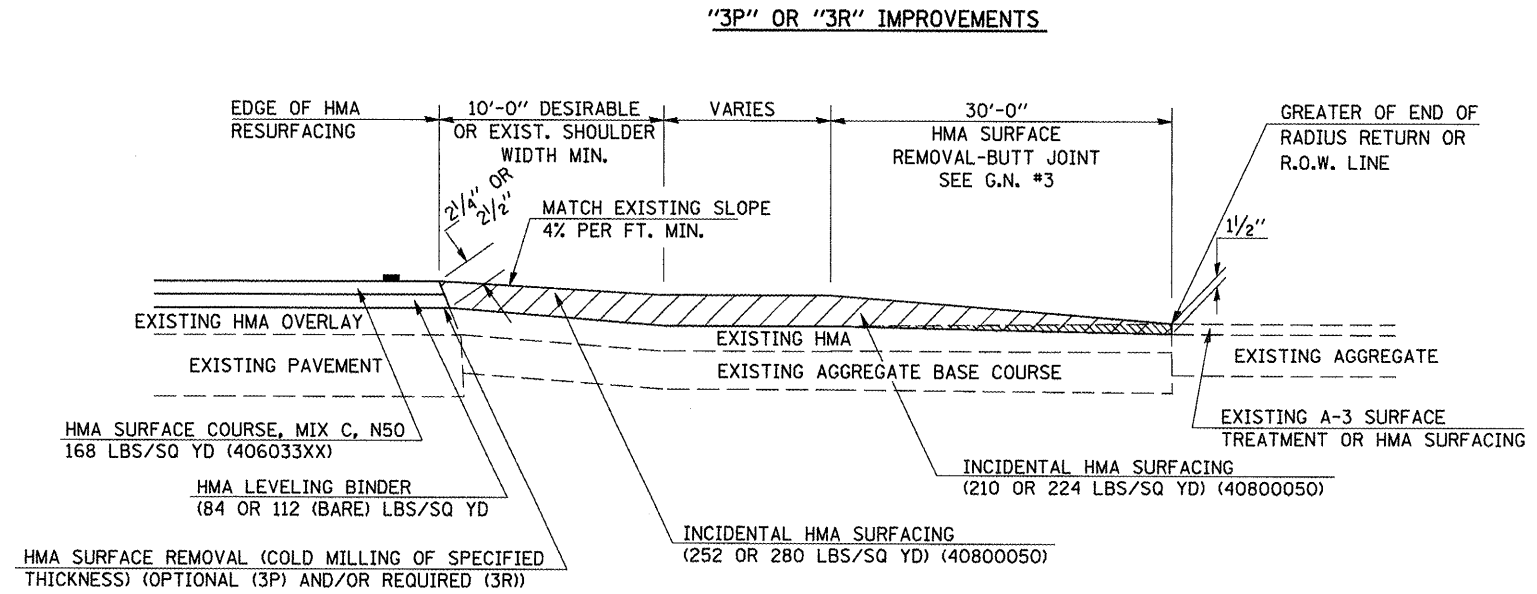
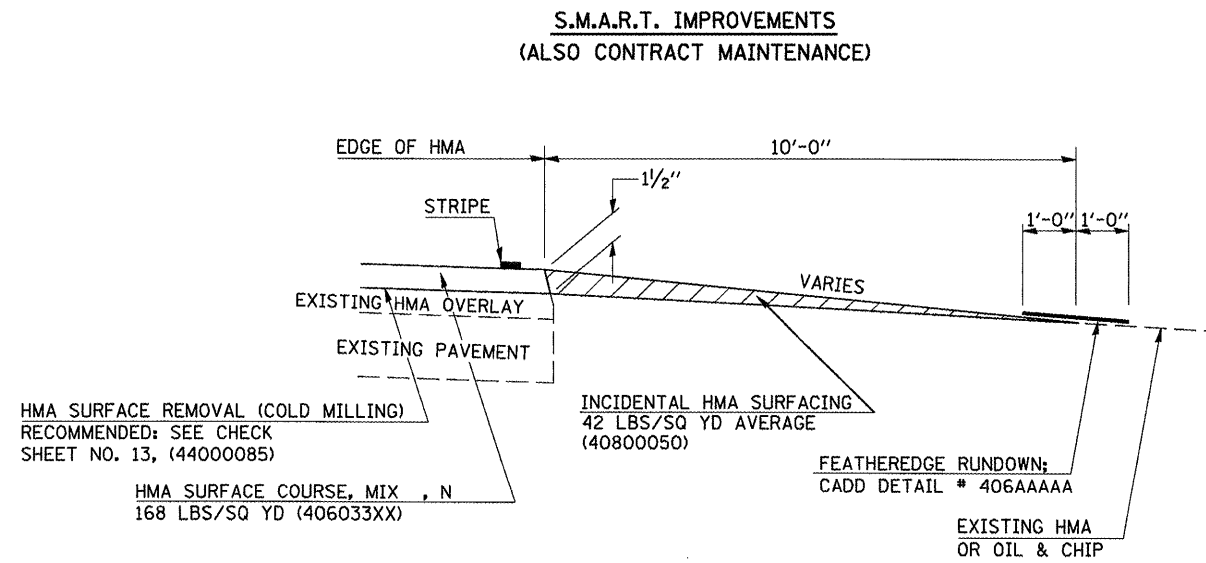

# PROJECTS WITH RECONSTRUCTION ( "3R" IMPROVEMENTS )

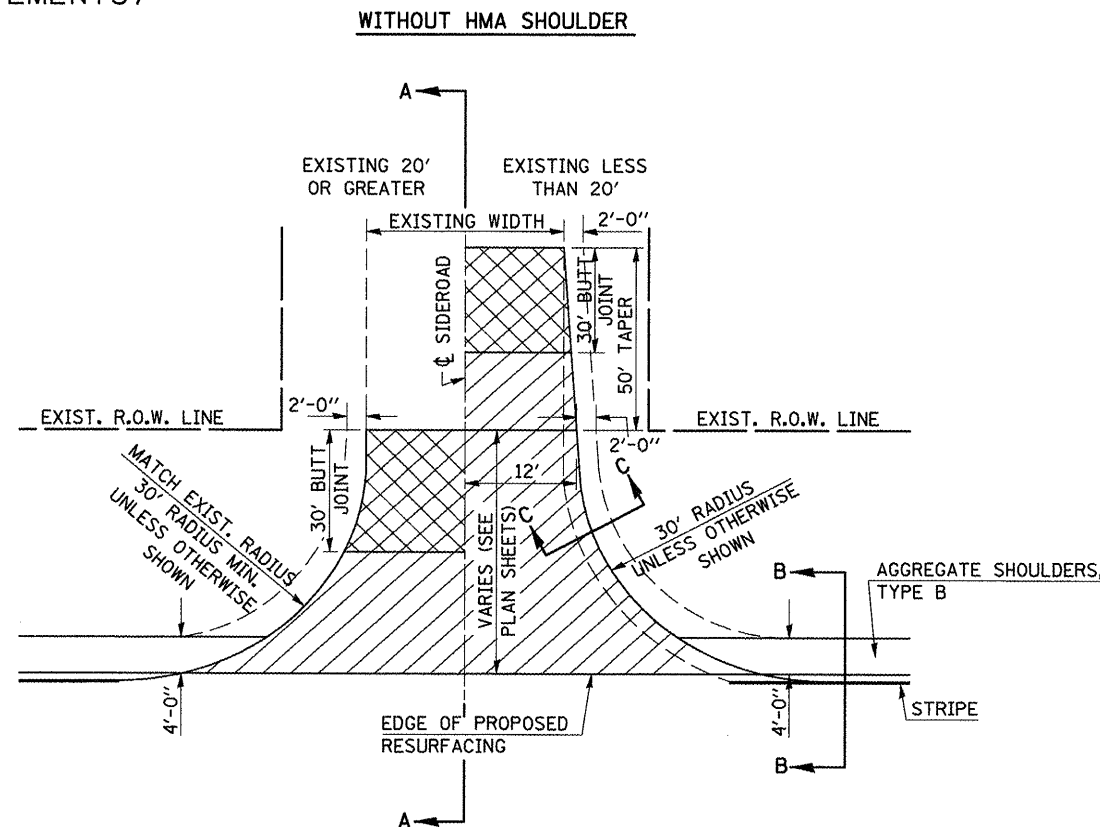
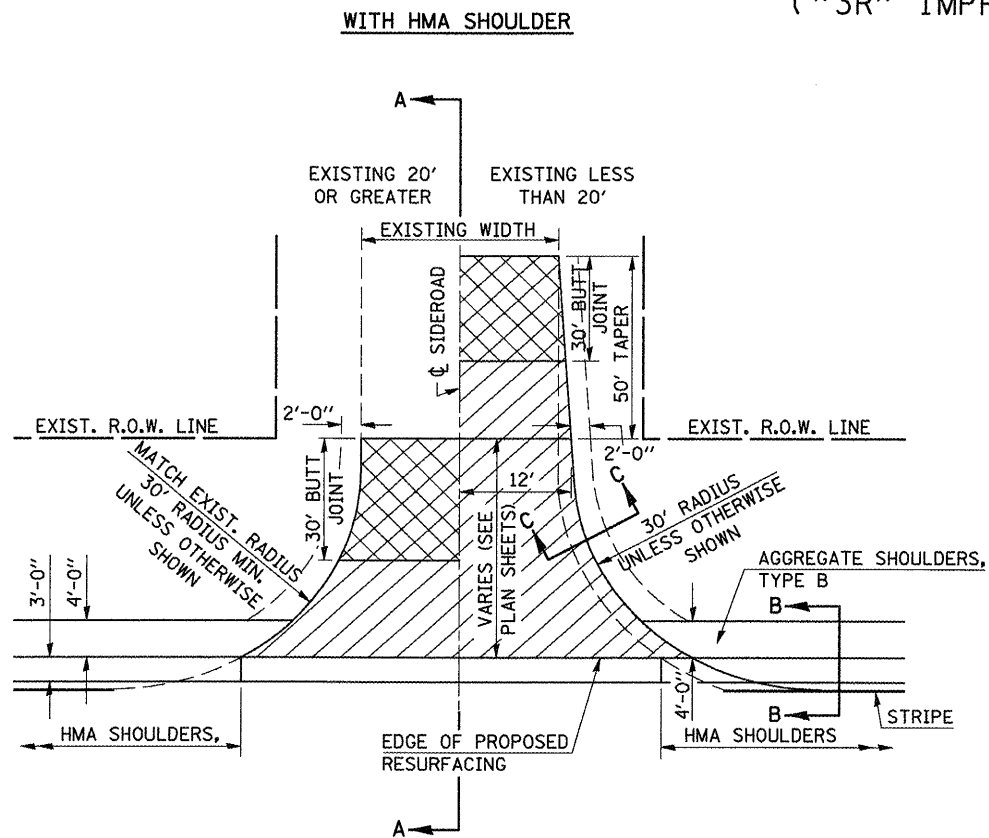

## GENERAL NOTES

1. THE EXISTING SURFACE SHALL BE PREPARED IN ACCORDANCE WITH SECTION 408 OF THE STANDARD SPECIFICATIONS
2. PROPOSED SIDEROAD GRADES SHALL BE AS SHOWN IN THE PLANS AND/OR AS DIRECTED BY THE ENGINEER.
3. MAJOR SIDEROAD/SIDESTREETS (>400 ADT) SHALL HAVE "BUTT JOINTS" CONSTRUCTED WHETHER THE EXISTING ENTRANCE IS HMA OR PCC. MINOR SIDEROAD/SIDESTREETS (<400 ADT) SHALL HAVE "FEATHEREDGE RUNDOWNS".
4. AGGREGATE BASE COURSE, TYPE B OF THE THICKNESS SPECIFIED IN THE PLANS 6" MIN. SHALL BE USED WHERE IN THE OPINION OF THE ENGINEER THERE IS NOT 6" EXISTING BASE MATERIAL FOR THE PROPOSED SIDEROAD RETURNS. THIS MATERIAL SHALL BE USED TO WIDEN SIDEROAD RETURNS.
5. THE AGGREGATE BASE COURSE SHALL BE CONSTRUCTED 1' WIDER THAN THE SURFACE DIMENSIONS.
6. AGGREGATE SHOULDERS, TYPE B WILL BE WRAPPED AROUND THE SIDEROAD RETURNS. TAPER WIDTH FROM 4' ALONG MAINLINE TO 2' AT BACK OF RETURN.

Note: All dimensions are in INCHES (millimeters) unless otherwise shown.

FILE NAME =	USER NAME = craisgr	DESIGNED -	REVISED - 12/13/06 TJB
c:\pwwork\pwwork\craisgr\d0112235\057051	l-sht-details.dgn	DRAWN -	REVISED - 09/21/07 KAG
PLOT SCALE = 48,0000 "/ IN.	CHECKED -	DATE -	REVISED -
PLOT DATE = 1/29/2009	DATE -	REVISED -	

**STATE OF ILLINOIS  
DEPARTMENT OF TRANSPORTATION**

**SIDEROADS & SIDESTREETS (RURAL)**

SCALE: NA SHEET NO. 1 OF 2 SHEETS STA. TO STA.

## DISTRICT 5 DETAIL NO. 408000AA

F.A.S. RTE.	SECTION	COUNTY	TOTAL SHEETS	SHEET NO.
1476	(55,56)RS-3	McLean	24	13
FED. ROAD DIST. NO. ILLINOIS FED. AID PROJECT			CONTRACT NO. 70511	

**SECTION A-A**  
EXISTING HMA OR PCC SIDEROAD (>400 ADT)

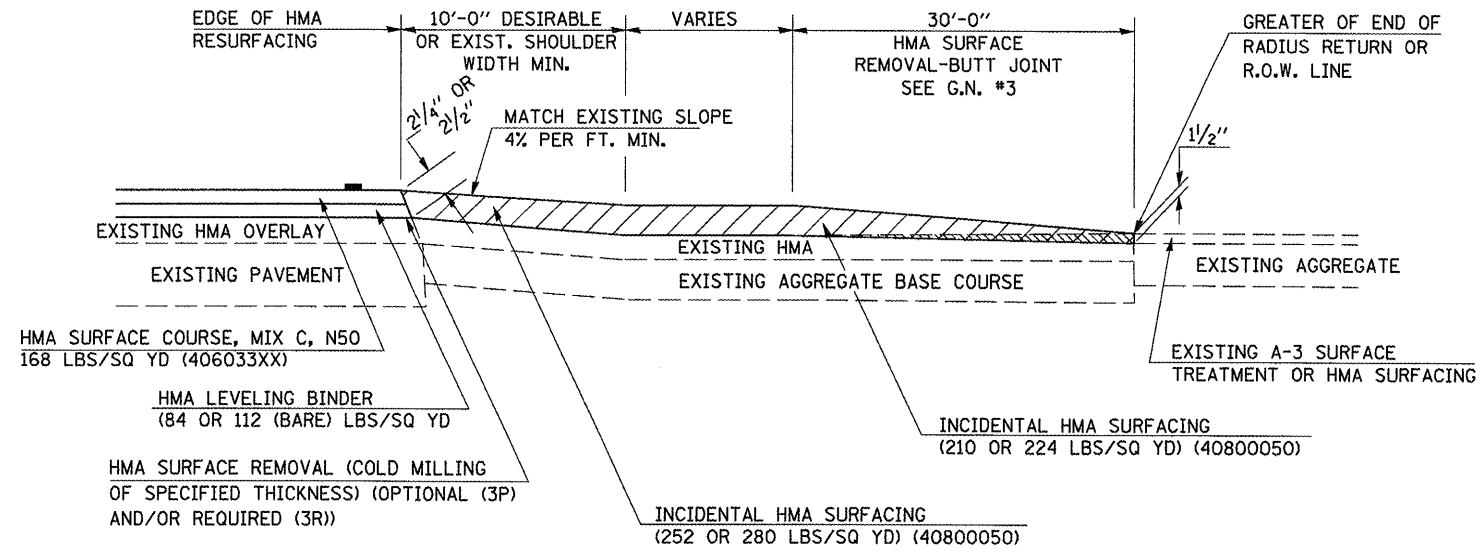

**SECTION A-A**  
EXISTING AGGREGATE OR SEAL COAT SIDEROAD (<400 ADT)

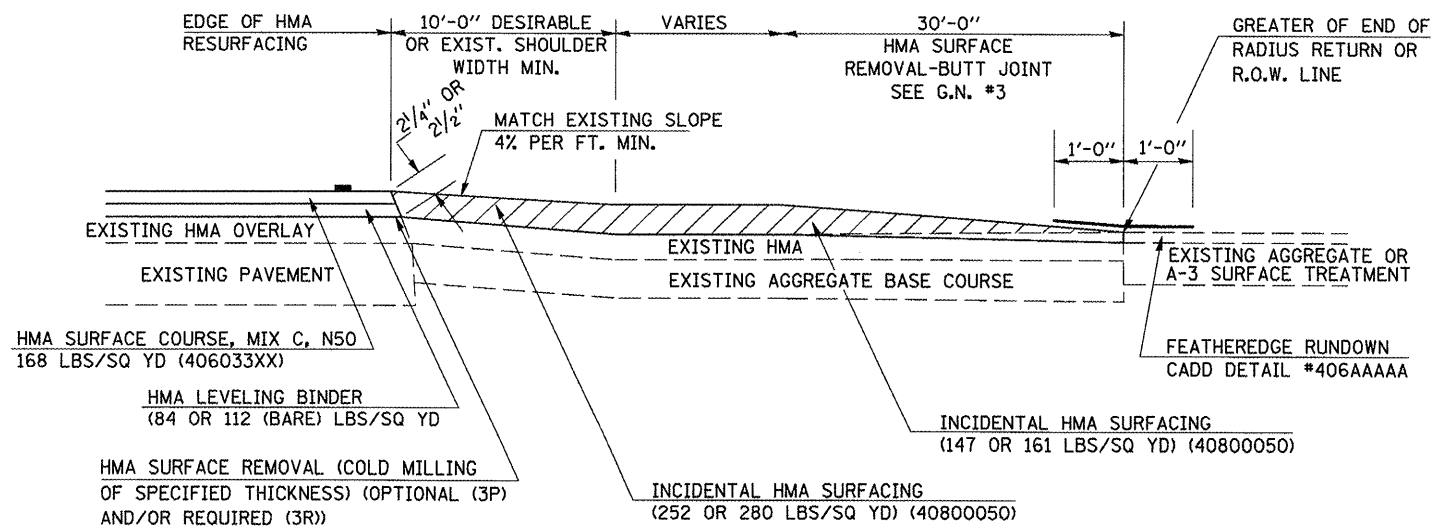

RURAL SIDEROAD DESIGN STANDARDS (PPM 40-06)									
DESIGN ELEMENT	New Construction & 3R (Existing Width Less Than 20 ft)			3R (Existing Width 20 ft or Greater) & 3P			SMART & Contract Maintenance		
	min.	des.	max.	min.	des.	max.	min.	des.	max.
SURFACE WIDTH (FT); (measured at end of radius or row line; greatest distance from edge of traveled way)	24	24	Coordinate with Geometrics Engineer	resurface existing configuration to completion of radius return or row line; greatest distance from edge of traveled way; major sideroads (> 400 adt) shall have "butt joints" constructed whether the entrance is hma or pcc; minor sideroads (< 400 adt) shall have "feathered edge" as shown in district cadd detail 406AAAAA					
RADIUS (FT)	30	30		resurface existing configuration with the completion of a 10 ft. feathered edge rundown for ALL sideroads as shown in district cadd detail 406AAAAA					
SHOULDER WIDTH (FT)	4	8	10						
SHOULDER SLOPE (%)	2	4	12						
ENTRANCE GRADE (%)	1	1 to 4	4						
BREAKOVER (%)	0	5	10						
SIDE SLOPE	1:10	1:6	1:4						
INTERSECTION ANGLE	60	75 to 90							
<b>SURFACE TYPE</b>									
INCIDENTAL HMA SURFACING (INCH)	4			taper from 2 1/4" to 1 1/2" or feathered edge			taper from 1 1/2" to feathered edge		
AGGREGATE BASE COURSE, TYPE A (INCH)	8	4		if applicable use item: 35800100 Preparation of Base					
PCC PAVEMENT (INCH)		8							

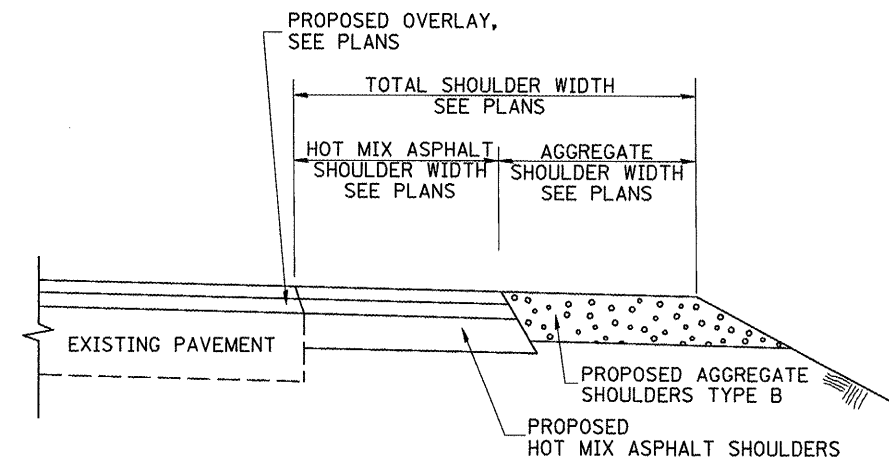

**SECTION B-B**  
MAINLINE SHOULDER TREATMENT

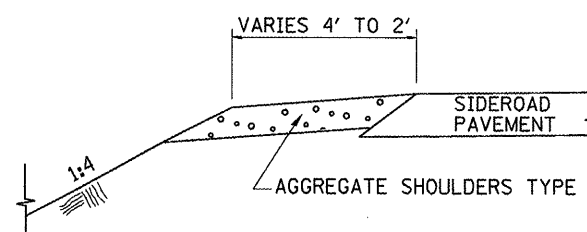

**SECTION C-C**  
SIDEROAD SHOULDER TREATMENT

Note: All dimensions are in INCHES (millimeters) unless otherwise shown.

FILE NAME =	USER NAME = craigre	DESIGNED -	REVISED - 12/13/06 TJB
cr:\pwork\pwork\craigre\d0112235\0570511-sht-details.dgn		DRAWN -	REVISED - 09/21/07 KAG
PLOT SCALE = 40.0000' / IN.		CHECKED -	REVISED -
PLOT DATE = 1/29/2009		DATE -	REVISED -

**STATE OF ILLINOIS**  
**DEPARTMENT OF TRANSPORTATION**

**SIDEROADS & SIDESTREETS (RURAL)**

SCALE: NA SHEET NO. 2 OF 2 SHEETS STA. TO STA.

**DISTRICT 5 DETAIL NO. 408000AA**

F.A.S. RTE.	SECTION	COUNTY	TOTAL SHEETS	SHEET NO.
1476	(55,56)RS-3	McLean	24	14
FED. ROAD DIST. NO. ILLINOIS FED. AID PROJECT			CONTRACT NO. 70511	

**PROJECTS WITHOUT RECONSTRUCTION**

("3R" WITHOUT RECONSTRUCTION, 3P, SMART AND CM)

**S.M.A.R.T. IMPROVEMENTS**

(POLICY RESURFACING; BDE 53-4.03; 1 1/2")

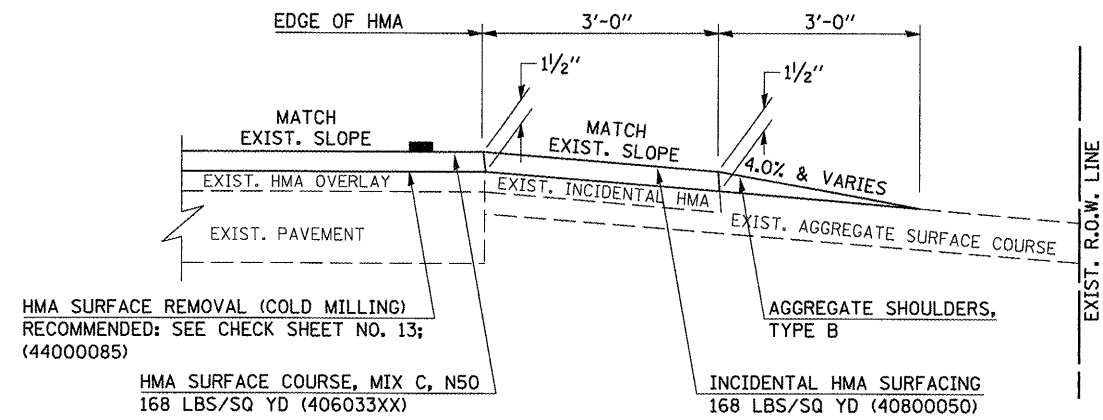

**"3P" OR "3R" IMPROVEMENTS**

(POLICY RESURFACING; BDE 53-4.02; 2 1/4" OR 2 1/2" ON BARE CONCRETE)

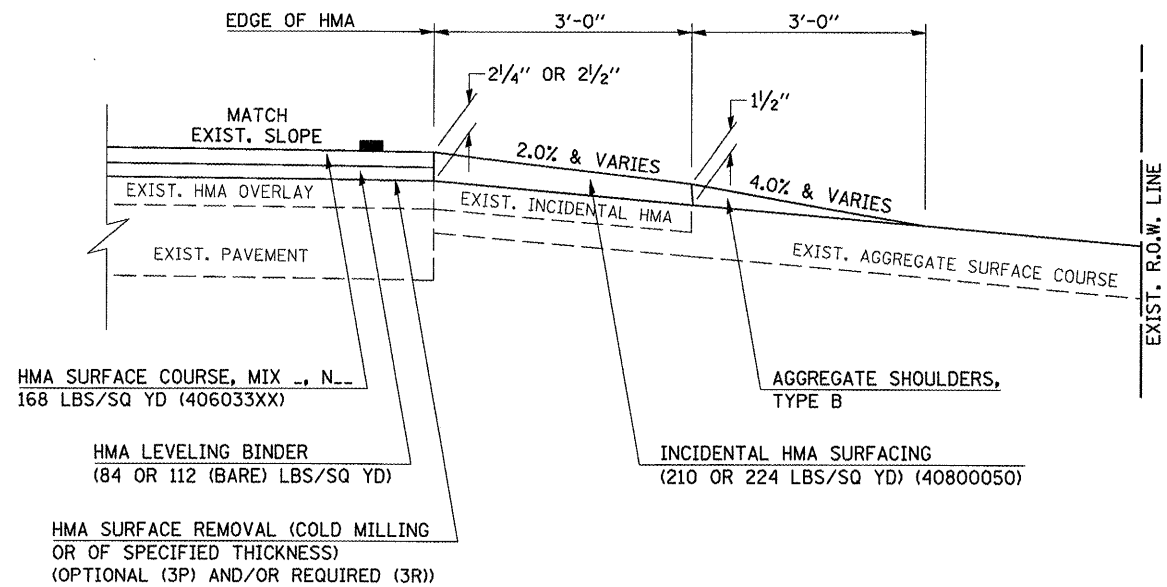

**PROJECTS WITH RECONSTRUCTION**

("3R" IMPROVEMENTS AND SMART/3P "SPOT" LOCATIONS)

**ADJACENT TO PROPOSED HMA SHOULDERS  
(AGGREGATE OR EARTH ENTRANCE)**

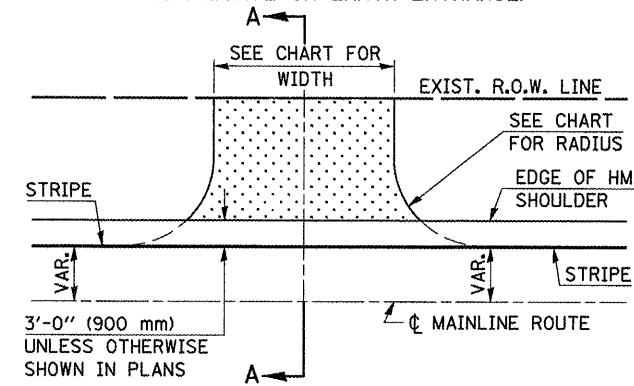

TYPICAL APPLICATION

**EXISTING AGGREGATE OR EARTH ENTRANCE**

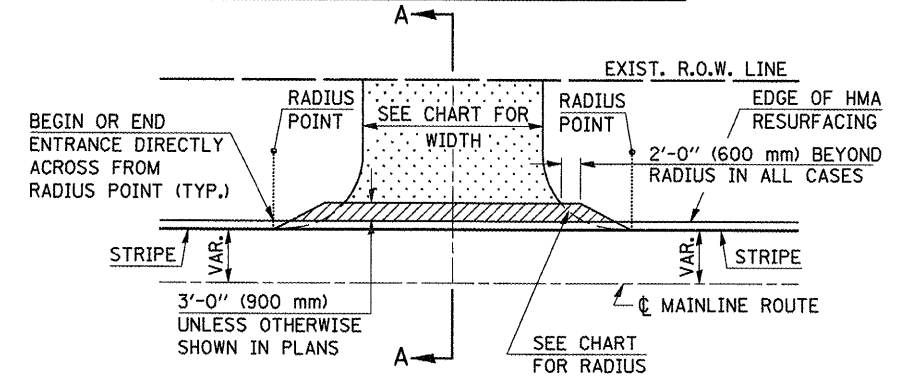

TYPICAL APPLICATION

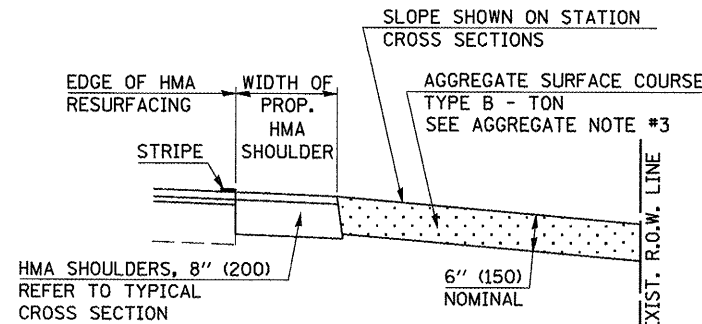

SECTION A-A

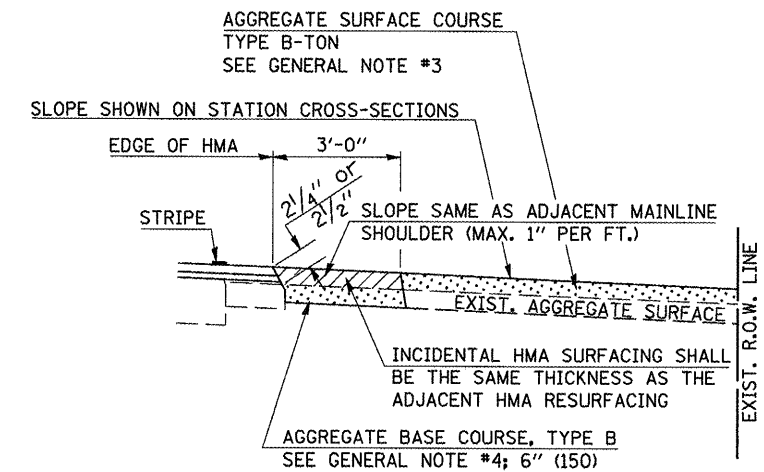

SECTION A-A

Note: All dimensions are in INCHES (millimeters) unless otherwise shown.

FILE NAME =	USER NAME = oiaigre	DESIGNED -	REVISED - 12/01/06 TJB
c:\pwwork\pwwork\oiaigre\d0112235\0570511-sht-detail.dgn		DRAWN -	REVISED - 09/21/07 KAG
	PLOT SCALE = 48.0000' / IN.	CHECKED -	REVISED - 04/30/08 KJT
	PLOT DATE = 1/29/2009	DATE -	REVISED -

STATE OF ILLINOIS  
DEPARTMENT OF TRANSPORTATION

FIELD ENTRANCES (NONCOMMERCIAL RURAL)

SCALE: NA SHEET NO. 1 OF 2 SHEETS STA. TO STA.

**DISTRICT 5 DETAIL NO. 4080050A**

F.A.S. RTE.	SECTION	COUNTY	TOTAL SHEETS	SHEET NO.
1476	(55,56)RS-3	McLean	24	15
FED. ROAD DIST. NO. ILLINOIS FED. AID PROJECT			CONTRACT NO. 70511	

RURAL ENTRANCE DESIGN STANDARDS (PPM 40-09)														
DESIGN ELEMENT	NEW CONSTRUCTION & 3R with RECONSTRUCTION									3R w/out RECONSTRUCTION, 3P, SMART & CM				
	NONCOMMERCIAL						COMMERCIAL			NONCOMMERCIAL			COMMERCIAL	
	PRIVATE & FIELD			FIELD W/ FARM IMPLEMENTS			COMMERCIAL			PRIVATE & FIELD			COMMERCIAL	
	min.	des.	max.	min.	max.	min.	des.	max.	min.	des.	max.	min.	des.	max.
SURFACE WIDTH (FT)	12	16	24	24	30	1 LANE, 1 WAY						1 LANE, 1 WAY		
						2 LANE, 2 WAY						2 LANE, 2 WAY		
						14	16	24						
RADIUS (FT)	15	25	40	30		24	30	35						
SHOULDER WIDTH (FT)	2	2		2		1	3		resurface existing configuration; existing aggregate or earth entrances shall have the continuation of aggregate shoulders placed behind them					
SHOULDER SLOPE (%)	2	4	6	4		2	4	6						
ENTRANCE GRADE (%)	0	2 to 5	10 or 12	2 to 5	10 or 12	0	2 to 5	8 or 10						
SIDE SLOPE (FT)	1:4	1:6	1:10	1:4	1:6	1:4	1:6	1:10						
<b>SURFACE TYPE</b>														
INCIDENTAL HMA SURFACING (INCH)		2		2		3 or 4			taper from hma resurfacing thickness (2 1/2", 2 1/4" or 1 1/2") to 1 1/2" to minimize aggregate shoulder					
AGGREGATE SURFACE COURSE, TYPE B (INCH)		6		6		8			if applicable use items: Preparation of Base & Aggregate Base Repair; see PPM 30-02					
PCC DRIVEWAY PAVEMENT (INCH)		6						6 or 8						

**GENERAL NOTES**

1. THE EXISTING SURFACE SHALL BE PREPARED IN ACCORDANCE WITH SECTION 408 OF THE STANDARD SPECIFICATIONS.
2. ANY NECESSARY WORK BEHIND THE HMA SHOULDER OR THE INCIDENTAL HMA SURFACING SHALL BE AS SHOWN IN THE PLANS AND/OR AS DIRECTED BY THE ENGINEER.
3. EARTH EXCAVATION REQUIRED FOR THE CONSTRUCTION OF THE AGGREGATE SURFACE COURSE SHALL BE INCLUDED IN THE COST OF AGGREGATE SURFACE COURSE.
4. AGGREGATE BASE COURSE, TYPE B, 6" (150 mm) MIN. SHALL BE USED WHERE IN THE OPINION OF THE ENGINEER THERE IS NOT SUFFICIENT BASE MATERIAL FOR THE PROPOSED ENTRANCES. THIS MATERIAL SHALL GENERALLY BE USED TO WIDEN ANY EXISTING RETURN OR TO CONSTRUCT NEW ENTRANCES WHERE NONE NOW EXISTS.
5. THE AGGREGATE BASE COURSE SHALL BE CONSTRUCTED 12" (300 mm) WIDER THAN THE SURFACE DIMENSIONS AS SHOWN ABOVE.
6. EXISTING FIELD ENTRANCES OF AGGREGATE OR EARTH WITH NO HMA APRON SHALL NOT RECEIVE A NEW HMA APRON WITHOUT PROPER APPROVAL THROUGH THE BUREAU OF OPERATIONS "POLICY ON PERMITS FOR ACCESS DRIVEWAYS TO STATE HIGHWAYS".
7. TO ASSURE APPROPRIATE ACCESS POLICIES ARE FOLLOWED ALL NEW ACCESS SHALL BE APPLIED FOR THROUGH THE BUREAU OF OPERATIONS PERMIT APPLICATION PROCESS. PLAN PREPARATION MEMORANDUMS 40-09 AND 40-11 ALONG WITH DISTRICT CONSTRUCTION MEMORANDUM 03/14 DISCUSS THIS PROCEDURE.

Note: All dimensions are in INCHES (millimeters) unless otherwise shown.

FILE NAME =	USER NAME = oreigre	DESIGNED -	REVISED - 12/01/06 TJB
at:\pwork\pwork\oreigre\d0112235\0570511-sht-details.dgn		DRAWN -	REVISED - 09/21/07 KAG
	PLOT SCALE = 40.0000' / IN.	CHECKED -	REVISED - 04/30/08 KJT
	PLOT DATE = 1/29/2009	DATE -	REVISED -

**STATE OF ILLINOIS  
DEPARTMENT OF TRANSPORTATION**

<b>FIELD ENTRANCES (NONCOMMERCIAL RURAL)</b>			
SCALE: NA	SHEET NO. 2 OF 2 SHEETS	STA.	TO STA.

<b>DISTRICT 5 DETAIL NO. 40800050A</b>				
F.A.S. RTE.	SECTION	COUNTY	TOTAL SHEETS	SHEET NO.
1476	(55,56)RS-3	McLean	24	16
FED. ROAD DIST. NO.			ILLINOIS FED. AID PROJECT	
			CONTRACT NO. 70511	



**PROJECTS WITHOUT RECONSTRUCTION**

**S.M.A.R.T. IMPROVEMENTS**  
(POLICY RESURFACING; BDE 53-4.03; 1/2")

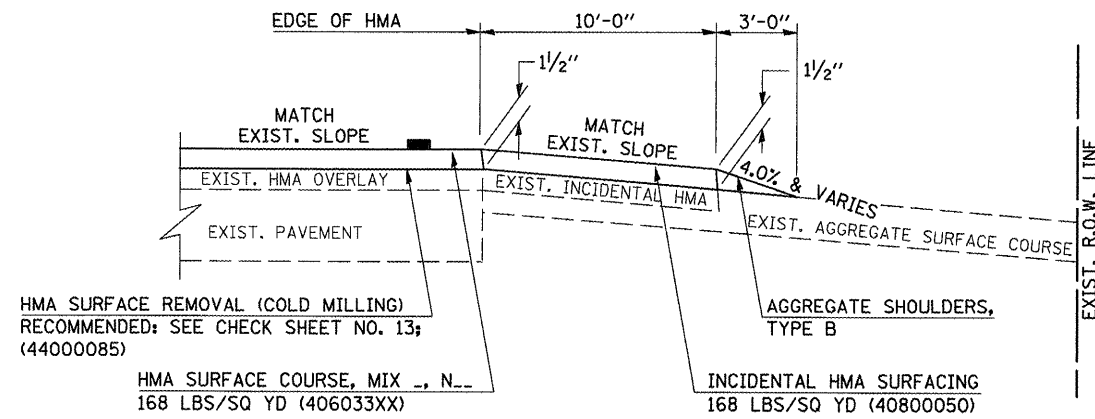

**EXISTING AGGREGATE ENTRANCE**

**"3P" OR "3R" IMPROVEMENTS**  
(POLICY RESURFACING; BDE 53-4.02; 2/4" OR 2/2" ON BARE CONCRETE)

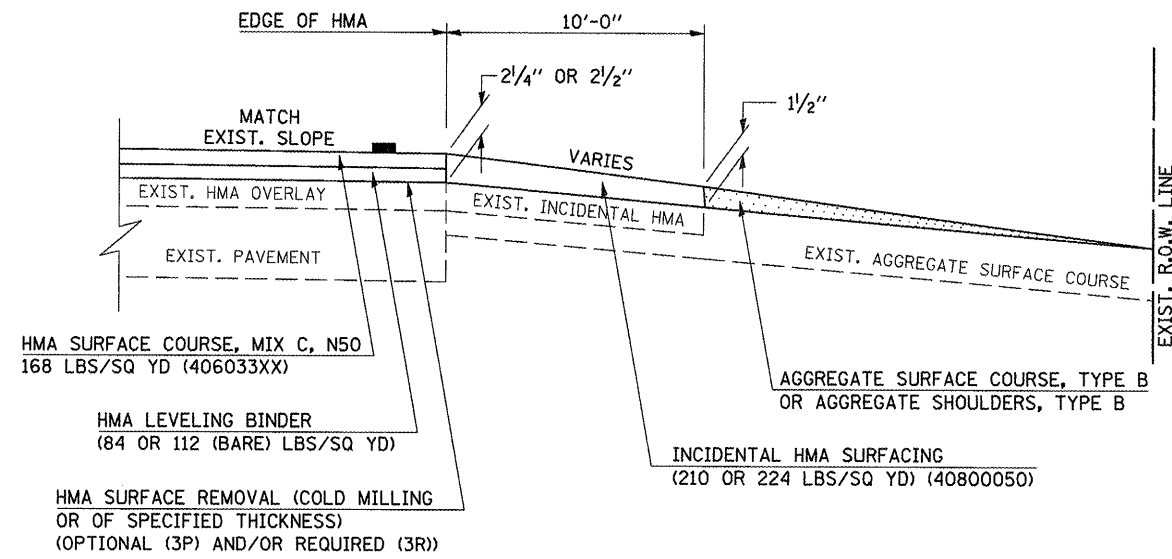

**EXISTING AGGREGATE ENTRANCE**

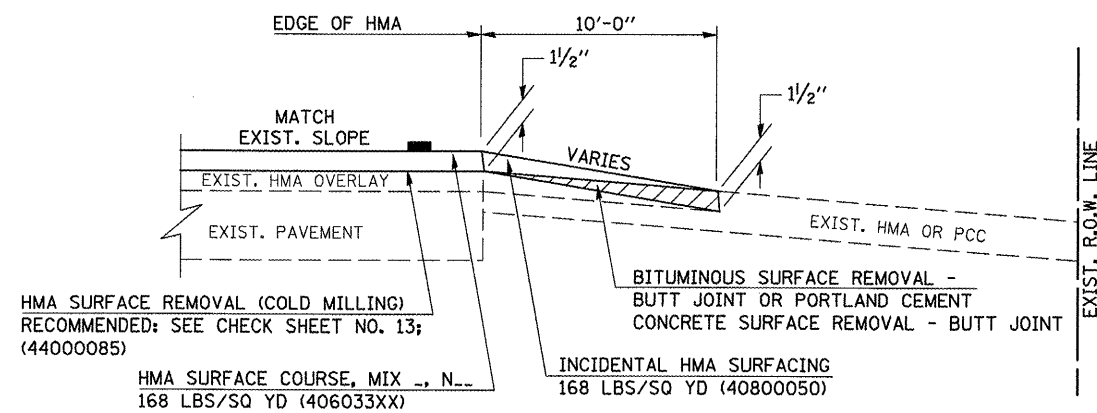

**EXISTING HMA OR PCC ENTRANCE**

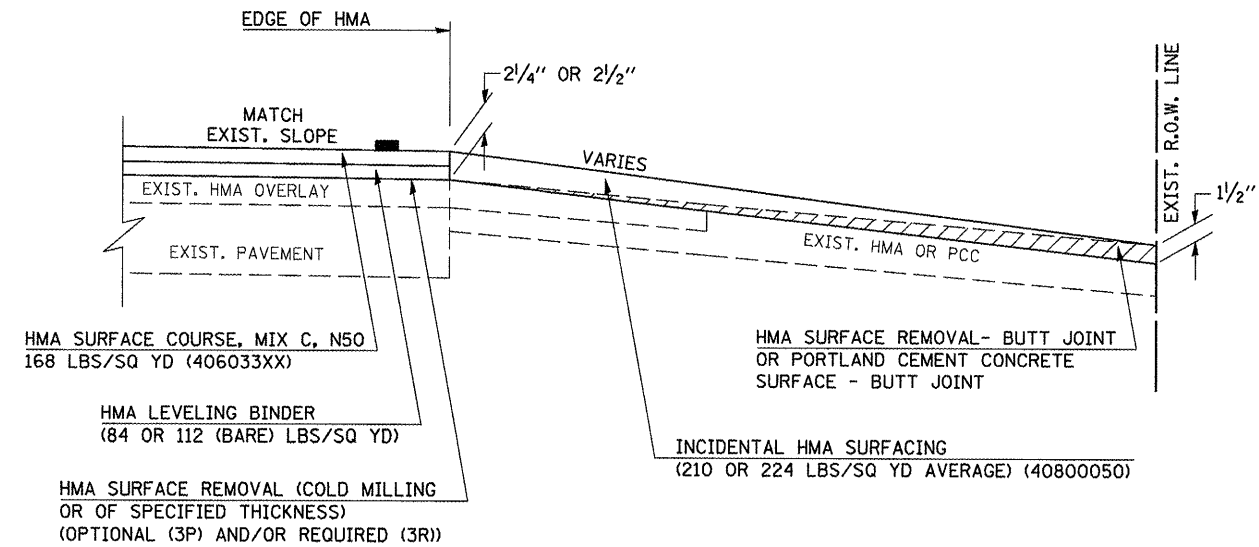

**EXISTING HMA OR PCC ENTRANCE**

Note: All dimensions are in INCHES (millimeters) unless otherwise shown.

FILE NAME =	USER NAME = craigre	DESIGNED -	REVISED - 12/08/06 TJB
cr:\pwork\pwork\craigre\d0112235\05708	l-sht-details.dgn	DRAWN -	REVISED - 09/21/07 KAG
	PLOT SCALE = 48.0000' / IN.	CHECKED -	REVISED - 05/02/08 KJT
	PLOT DATE = 1/29/2009	DATE -	REVISED -

**STATE OF ILLINOIS**  
**DEPARTMENT OF TRANSPORTATION**

**PRIVATE AND COMMERCIAL ENTRANCES**  
(NONCOMMERCIAL AND COMMERCIAL RURAL)

SCALE: NA SHEET NO. 1 OF 2 SHEETS STA. TO STA.

**DISTRICT 5 DETAIL NO. 40800050C**

F.A.S. RTE.	SECTION	COUNTY	TOTAL SHEETS	SHEET NO.
1476	(55,56)RS-3	McLean	24	17
FED. ROAD DIST. NO. ILLINOIS FED. AID PROJECT			CONTRACT NO. 70511	

# PROJECTS WITH RECONSTRUCTION

(3R IMPROVEMENTS)

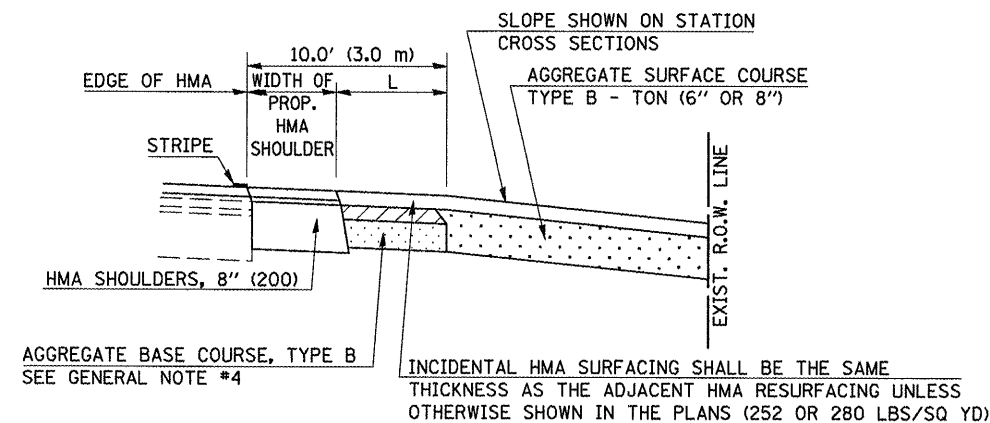
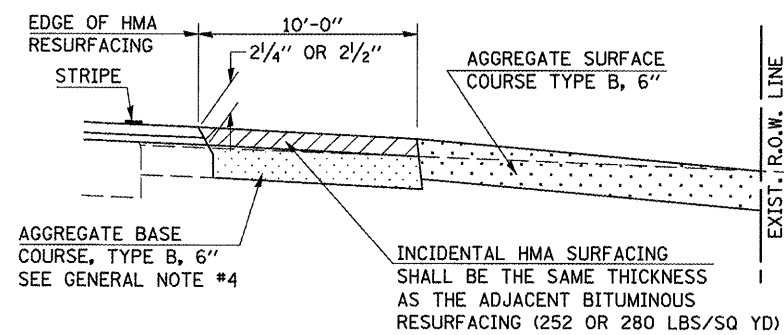
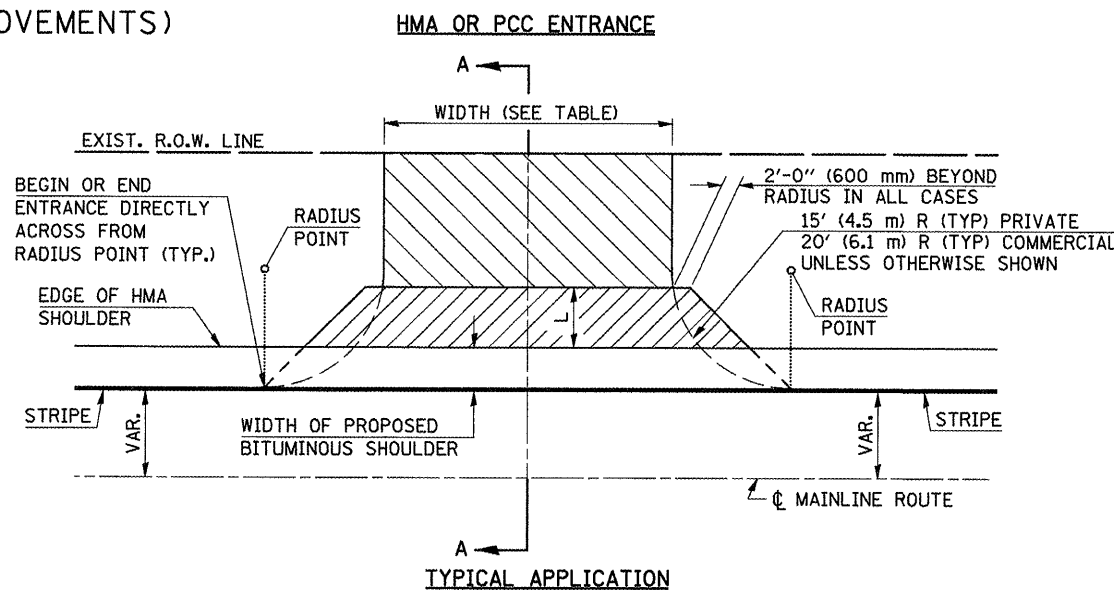
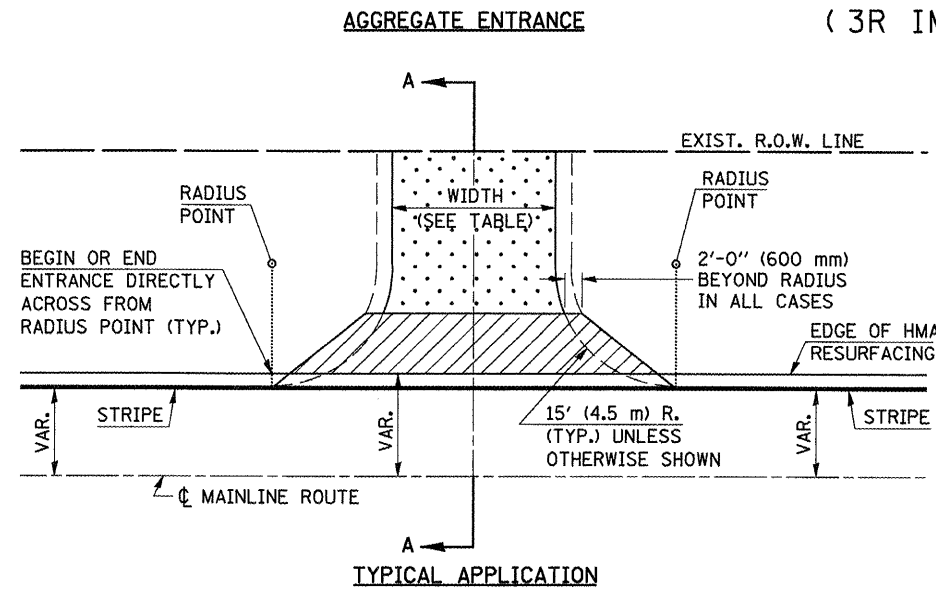

## GENERAL NOTES

1. THE EXISTING SURFACE SHALL BE PREPARED IN ACCORDANCE WITH SECTION 408 OF THE STANDARD SPECIFICATIONS.
2. ANY NECESSARY WORK BEHIND THE HMA SHOULDER OR THE INCIDENTAL HMA SURFACING SHALL BE AS SHOWN IN THE PLANS AND/OR AS DIRECTED BY THE ENGINEER.
3. EARTH EXCAVATION REQUIRED FOR THE CONSTRUCTION OF THE AGGREGATE SURFACE COURSE SHALL BE INCLUDED IN THE COST OF AGGREGATE SURFACE COURSE.
4. AGGREGATE BASE COURSE, TYPE B, 6" (150 mm) MIN. SHALL BE USED WHERE IN THE OPINION OF THE ENGINEER THERE IS NOT SUFFICIENT BASE MATERIAL FOR THE PROPOSED ENTRANCES. THIS MATERIAL SHALL GENERALLY BE USED TO WIDEN ANY EXISTING RETURN OR TO CONSTRUCT NEW ENTRANCES WHERE NONE NOW EXISTS.
5. THE AGGREGATE BASE COURSE SHALL BE CONSTRUCTED 12" (300 mm) WIDER THAN THE SURFACE DIMENSIONS AS SHOWN ABOVE.
6. EXISTING FIELD ENTRANCES OF AGGREGATE OR EARTH WITH NO HMA APRON SHALL NOT RECEIVE A NEW HMA APRON WITHOUT PROPER APPROVAL THROUGH THE BUREAU OF OPERATIONS "POLICY ON PERMITS FOR ACCESS DRIVEWAYS TO STATE HIGHWAYS".
7. TO ASSURE APPROPRIATE ACCESS POLICIES ARE FOLLOWED ALL NEW ACCESS SHALL BE APPLIED FOR THROUGH THE BUREAU OF OPERATIONS PERMIT APPLICATION PROCESS. PLAN PREPARATION MEMORANDUMS 40-09 AND 40-11 ALONG WITH DISTRICT CONSTRUCTION MEMORANDUM 03/14 DISCUSS THIS PROCEDURE.

RURAL ENTRANCE DESIGN STANDARDS (PPM 40-09)																	
DESIGN ELEMENT	NEW CONSTRUCTION & 3R with RECONSTRUCTION						3R w/out RECONSTRUCTION, 3P, SMART & CM										
	NONCOMMERCIAL			FIELD W/ FARM IMPLEMENTS			COMMERCIAL			NONCOMMERCIAL			COMMERCIAL				
	min.	des.	max.	min.	max.	min.	des.	max.	min.	des.	max.	min.	des.	max.			
SURFACE WIDTH (FT)	12	16	24	24	30	1 LANE, 1 WAY			1 LANE, 1 WAY								
						14	16	24	2 LANE, 2 WAY								
RADIUS (FT)	15	25	40	30		24	30	35	resurface existing configuration; existing hma or pcc entrances shall have "butt joints" constructed; existing aggregate or earth entrances shall have the continuation of aggregate shoulders placed behind them								
SHOULDER WIDTH (FT)	2	2		2		1	3		taper from hma resurfacing thickness (2 1/2", 2 1/4" or 1 1/2") to 1 1/2" for "butt joints" and to minimize aggregate shoulder								
SHOULDER SLOPE (%)	2	4	6	4		2	4	6	if applicable use items: Preparation of Base & Aggregate Base Repair; see PPM 30-02								
ENTRANCE GRADE (%)	0	2 to 5	10 or 12	2 to 5	10 or 12	0	2 to 5	8 or 10	6 or 8								
SIDE SLOPE (FT)	1:10	1:6	1:4	1:6	1:4	1:10	1:6	1:4									
<b>SURFACE TYPE</b>																	
INCIDENTAL HMA SURFACING (INCH)		2		2		3 or 4											
AGGREGATE SURFACE COURSE, TYPE B (INCH)		6		6		8											
PCC DRIVEWAY PAVEMENT (INCH)		6															

Note: All dimensions are in INCHES (millimeters) unless otherwise shown.

FILE NAME =	USER NAME = oraigne	DESIGNED -	REVISED - 12/08/06 TJB
ca:\pwork\pwork\oraigne\d0112235\0570511-sht-detail.dgn		DRAWN -	REVISED - 09/21/07 KAG
	PLOT SCALE = 48.0000' / IN.	CHECKED -	REVISED - 05/02/08 KJT
	PLOT DATE = 1/29/2009	DATE -	REVISED -

STATE OF ILLINOIS  
DEPARTMENT OF TRANSPORTATION

PRIVATE AND COMMERCIAL ENTRANCES  
(NONCOMMERCIAL AND COMMERCIAL RURAL)

SCALE: NA SHEET NO. 2 OF 2 SHEETS STA. TO STA.

DISTRICT 5 DETAIL NO. 4080050C				
F.A.S. RTE.	SECTION	COUNTY	TOTAL SHEETS	SHEET NO.
1476	(55,56)RS-3	McLean	24	18
FED. ROAD DIST. NO.			ILLINOIS FED. AID PROJECT	
			CONTRACT NO. 70511	

# ROAD CLOSURE

# SIDEROAD / STREET CLOSURE

SYMBOLS	
	TYPE III BARRICADE (SEE NOTE 1)
	FLASHING AMBER LIGHT (TYPE A)

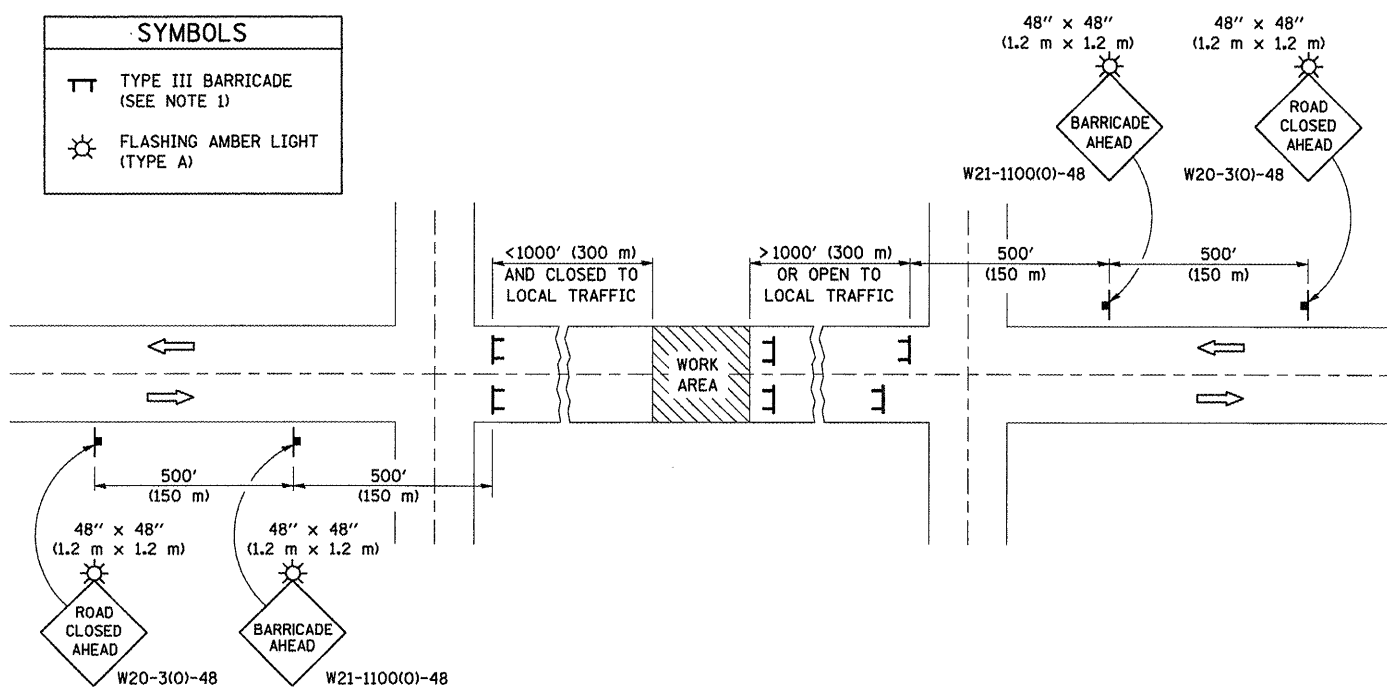

SYMBOLS	
	TYPE III BARRICADE (SEE NOTE)
	FLASHING LIGHT
	FLAGGER WITH TRAFFIC CONTROL SIGN (WHILE WORK IS BEING PERFORMED)
	CONE (DAYLIGHT HOURS ONLY), DRUM, TYPE I OR TYPE II BARRICADE
	WORK AREA
	TRAFFIC FLOW

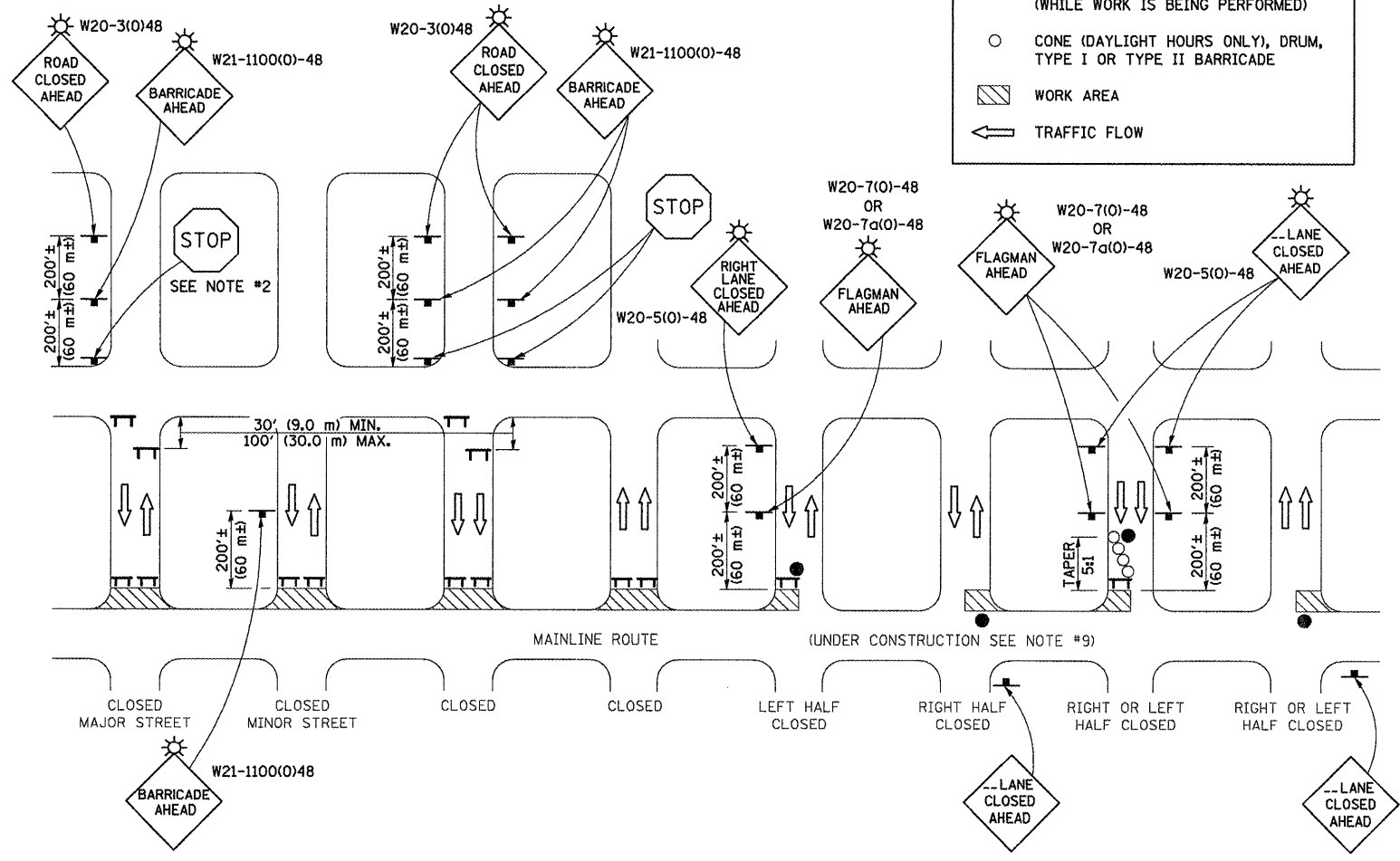

### GENERAL NOTES

- TYPE III BARRICADES SHALL BE AS SHOWN ON STANDARD 701901 "TYPICAL APPLICATIONS OF TYPE III BARRICADES CLOSING A ROAD". EACH TYPE III BARRICADE SHALL HAVE TWO FLASHING AMBER LIGHTS MOUNTED ABOVE IT.
- IF THE ROAD IS OPEN TO LOCAL TRAFFIC OR EXCEEDS 1000' (300 m), ANOTHER SET OF TYPE III BARRICADES, EQUIPPED AS IN NOTE 1 ABOVE, SHALL BE PLACED AT EACH END OF THE WORK AREA.
- WHEN A STOP CONDITION EXISTS, NO SIGNS ARE REQUIRED IN ADVANCE OF THE "STOP" SIGN WHEN THE ROAD IS CLOSED WITHIN 100' (30 m) OF THE INTERSECTION.
- STANDARD 701901 SHALL APPLY FOR THE PLACEMENT & DESIGN OF TYPE III BARRICADES.
- IF A TYPE III BARRICADE WITH AN ATTACHED SIGN PANEL WHICH MEETS NCHRP 350 IS NOT AVAILABLE, THE SIGNS MAY BE MOUNTED ON AN NCHRP 350 TEMPORARY SIGN SUPPORT DIRECTLY IN FRONT OF THE BARRICADE.
- REFLECTORIZED STRIPING SHALL APPEAR ON BOTH SIDES OF THE TYPE III BARRICADES IF ROAD IS OPEN TO LOCAL TRAFFIC.
- ALL SIGNS SHALL BE POST MOUNTED IF THE CLOSURE TIME EXCEEDS FOUR DAYS.
- A MINIMUM OF TWO FLASHING LIGHTS SHALL BE USED AT NIGHT ON EACH APPROACH IN ADVANCE OF THE WORK AREA. FLASHING LIGHTS SHALL BE INSTALLED ABOVE THE FIRST TWO SIGNS IN THE SERIES.
- LONGITUDINAL DIMENSIONS MAY BE ADJUSTED SLIGHTLY TO FIT FIELD CONDITIONS.
- FORMS BT, 725 AND BT, 726 ARE REQUIRED.
- WHEN A SIDEROAD INTERSECTS THE HIGHWAY ON WHICH WORK IS BEING PERFORMED, ADDITIONAL TRAFFIC DEVICES SHALL BE ERECTED AND PROVIDED AS DIRECTED BY THE ENGINEER.
- AN ADDITIONAL SIGN MAY BE REQUIRED AT A MAJOR INTERSECTING ROAD IN ADVANCE OF THE CLOSURE. THE ADDITIONAL SIGN SHALL GIVE THE DISTANCE TO THE BARRICADE IN MILES OR FRACTIONS OF A MILE.

### GENERAL NOTES

- TYPE III BARRICADES SHALL BE AS SHOWN ON "TYPICAL APPLICATIONS OF TYPE III BARRICADES CLOSING A ROAD". EACH TYPE III BARRICADE SHALL HAVE TWO FLASHING AMBER LIGHTS MOUNTED ABOVE IT.
- WHERE A STOP CONDITION EXISTS, AS SHOWN ABOVE, WARNING SIGNS MAY BE OMITTED IN ADVANCE OF THE "STOP" SIGN.
- STANDARD 701901 SHALL APPLY FOR THE PLACEMENT & MANUFACTURE OF TYPE III BARRICADES.
- ALL SIGNS SHALL BE POST MOUNTED IF THE CLOSURE TIME EXCEEDS FOUR DAYS.
- ONE FLASHING LIGHT IS REQUIRED ABOVE EACH ADVANCE WARNING SIGN DURING HOURS OF DARKNESS.
- LONGITUDINAL DIMENSIONS MAY BE ADJUSTED SLIGHTLY TO FIT FIELD CONDITIONS.
- FORMS BT 725 AND BT 726 ARE REQUIRED.
- THE MAINLINE ROUTE TEMPORARY TRAFFIC CONTROL SHALL BE IN ACCORDANCE WITH THE PLANS, SPECIAL PROVISIONS AND STANDARD SPECIFICATIONS.
- THIS WORK WILL NOT BE PAID FOR SEPARATELY BUT SHALL BE CONSIDERED INCLUDED IN THE VARIOUS PAY ITEMS INVOLVING THE RECONSTRUCTION OF ALL APPLICABLE SIDE STREETS AND NO ADDITIONAL COMPENSATION WILL BE ALLOWED.

Note: All dimensions are in INCHES (millimeters) unless otherwise shown.

FILE NAME =	USER NAME = craigra	DESIGNED -	REVISED - 11/06
c:\pwwork\pwwork\craigra\d0112235\05705	l=shd-deta11s.dgn	DRAWN -	REVISED - 12/07
	PLOT SCALE = 48.0000 "/ IN.	CHECKED -	REVISED -
	PLOT DATE = 1/29/2009	DATE -	REVISED -

**STATE OF ILLINOIS  
DEPARTMENT OF TRANSPORTATION**

**TRAFFIC CONTROL & PROTECTION DEVICES  
(ROAD & SIDEROAD/STREET CLOSURES)**

<b>DISTRICT 5 DETAIL NO. 7020000</b>				
F.A.S. RTE.	SECTION	COUNTY	TOTAL SHEETS	SHEET NO.
1476	(55,56)RS-3	McLean	24	19
FED. ROAD DIST. NO.			ILLINOIS FED. AID PROJECT	
CONTRACT NO. 70511				

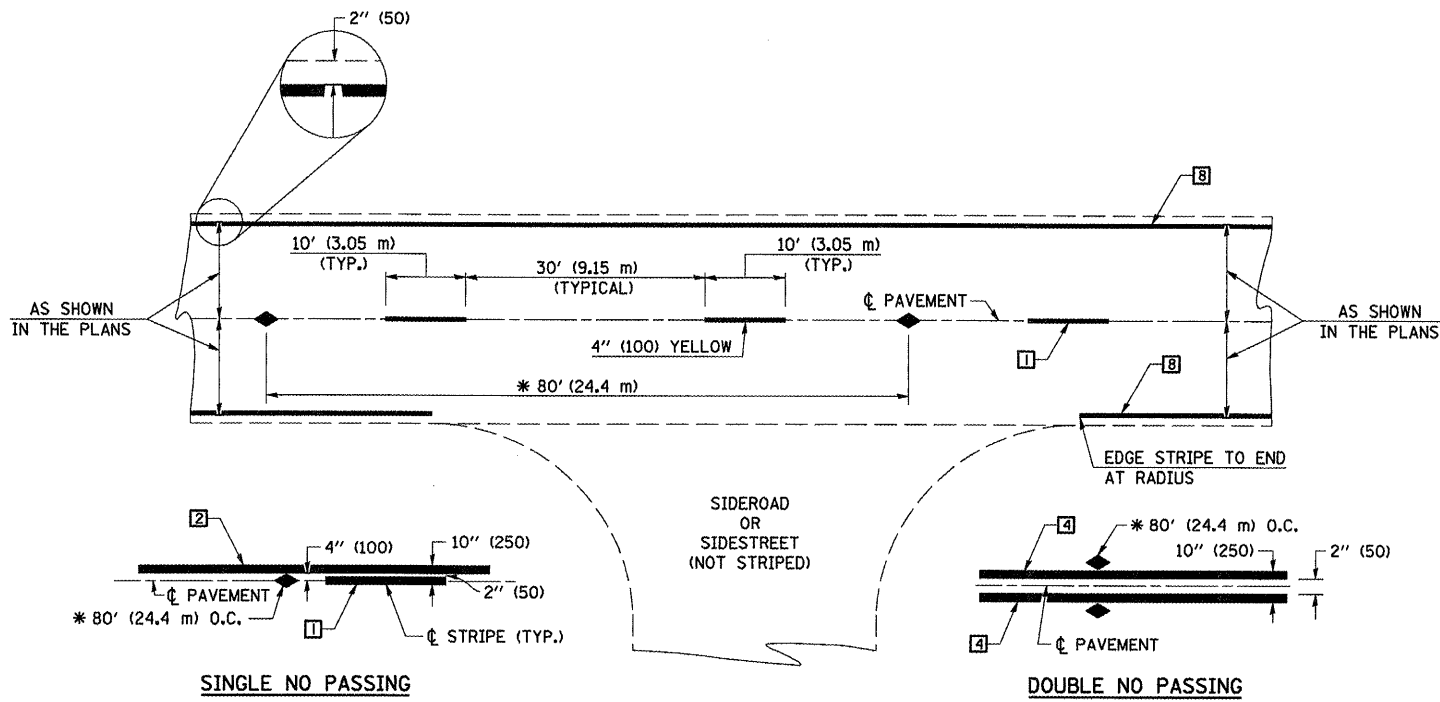

\* REDUCE TO 40' (12.2 m) O.C. ON CURVES WITH POSTED OR ADVISORY SPEEDS OF 45 mph (70 km/h) OR LESS.

**TWO LANE/TWO WAY**

**TYPICAL PAVEMENT MARKING LEGEND**

- 1 4" (100) SKIP-DASH (YELLOW)
- 2 4" (100) SOLID (YELLOW)
- 3 12" (300) DIAGONAL (YELLOW)
- 4 4" (100) DOUBLE YELLOW (NARROW)
- 5 RESERVED
- 6 RESERVED
- 7 4" (100) SKIP-DASH (WHITE)
- 8 4" (100) SOLID (WHITE)
- 9 12" (300) DIAGONAL (WHITE)
- 10 6" (150) SOLID (WHITE)
- 11 24" (600) STOP BAR (WHITE)
- 12 8" (200) SOLID (WHITE)
- 13 4" (100) LANE LINE EXTENSIONS (WHITE)
- 14 4" (100) PARKING WHITE

**TYPICAL PAVEMENT MARKERS LEGEND**

- ◆ TWO-WAY AMBER MARKER
- ▶ ONE-WAY AMBER MARKER
- ▷ ONE-WAY CRYSTAL MARKER

**RURAL LEFT TURN**

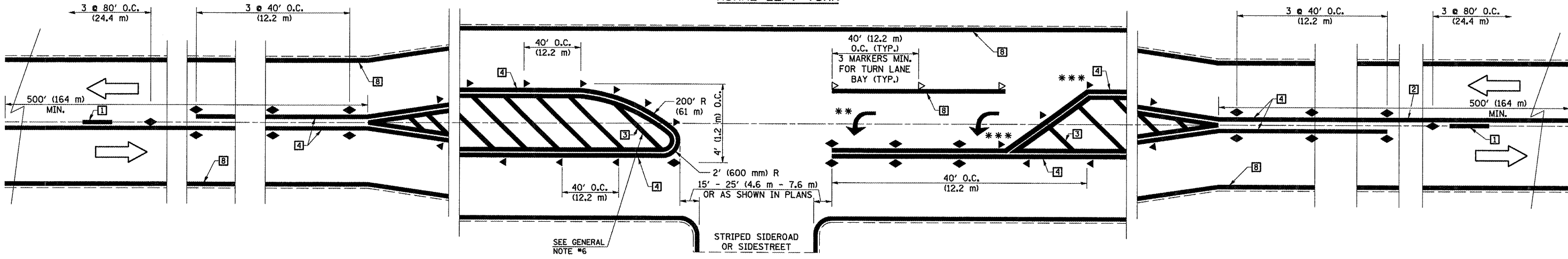

\*\*\* REDUCE SPACING IF NECESSARY TO ASSURE MARKERS AT CORNER POINTS.

\*\* TURN ARROWS SHALL BE PLACED AS SHOWN ON SHEET #2.

Note: All dimensions are in INCHES (millimeters) unless otherwise shown.

FILE NAME =	USER NAME = craigre	DESIGNED -	REVISED - 11/06
at:\pwork\pwork\pwork\craigre\d0112235\1-sht-detail.dgn		DRAWN -	REVISED -
	PLOT SCALE = 48.0000' / IN.	CHECKED -	REVISED -
	PLOT DATE = 1/29/2009	DATE -	REVISED -

**STATE OF ILLINOIS  
DEPARTMENT OF TRANSPORTATION**

**PAVEMENT MARKING AND MARKERS  
(RURAL & URBAN APPLICATIONS)**

SCALE: SHEET NO. 1 OF 4 SHEETS STA. TO STA.

<b>DISTRICT 5 DETAIL NO. 7800AAAA</b>				
F.A.S. RTE.	SECTION	COUNTY	TOTAL SHEETS	SHEET NO.
1476	(55,56)RS-3	McLean	24	20
FED. ROAD DIST. NO.			CONTRACT NO. 70511	
ILLINOIS FED. AID PROJECT				

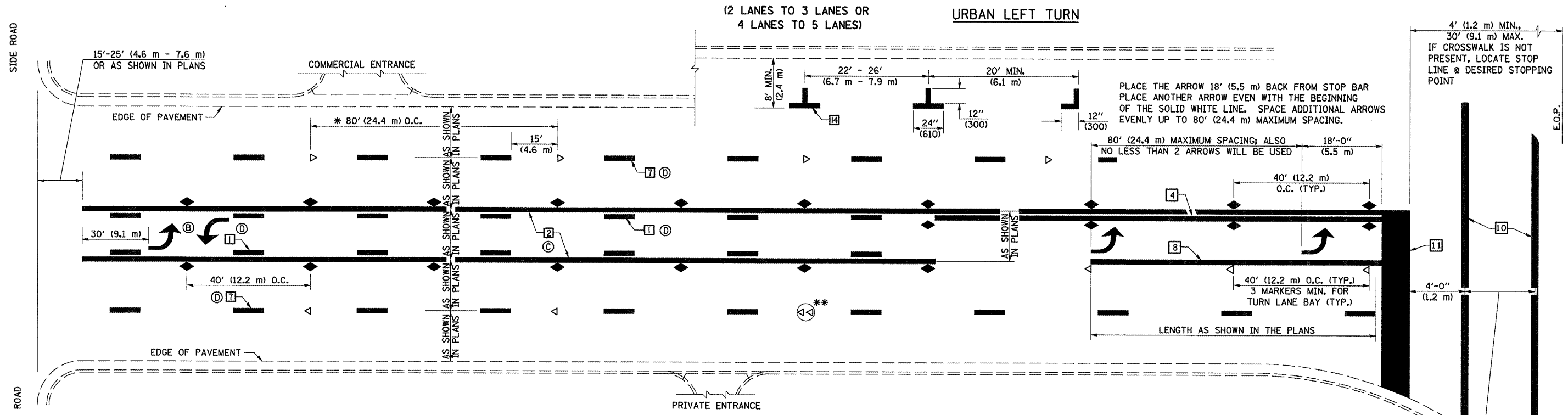

\* REDUCE TO 40 FEET (12.2 METERS) ON CENTER ON CURVES WHERE ADVISORY SPEEDS ARE 10 MPH (15 km/h) LOWER THAN POSTED SPEEDS.

\*\* DOUBLE LANE LINE MARKERS SHALL BE SPECIFIED AND SPACED AS SHOWN IN HIGHWAY STANDARD 781001 FOR MULTI-LANE DIVIDED AND UNDIVIDED HIGHWAYS.

**GENERAL NOTES:**

- Ⓑ TURN ARROW PAIRS SHALL BE PLACED AT 250' (75 m) INTERVALS AND SHALL BE EVENLY SPACED BETWEEN BOTH ENDS OF THE BIDIRECTIONAL LEFT TURN LANE.
- Ⓒ THE SOLID YELLOW PAVEMENT MARKINGS [2] SHOULD GENERALLY START OR END NEAR THE RADIUS POINT OF EACH STREET RETURN EXCEPT WHERE ONE OR BOTH ENDS WOULD INCLUDE STOP BARS.
- Ⓓ THE SKIP-DASH PAVEMENT MARKINGS [1] OR [7] SHOULD BE CENTERED BETWEEN BOTH ENDS OF EACH CITY BLOCK AND SHALL BE PLACED SO THEY LINE UP ACROSS FROM EACH OTHER. SEE EXAMPLE ON SHEET 2 OF 3.
- Ⓔ USE LARGE ARROW SIZE FOR BOTH RURAL AND URBAN LOCATIONS. (SEE LAST PAGE OF SECTION 780x FOR SYMBOLS TABLE)

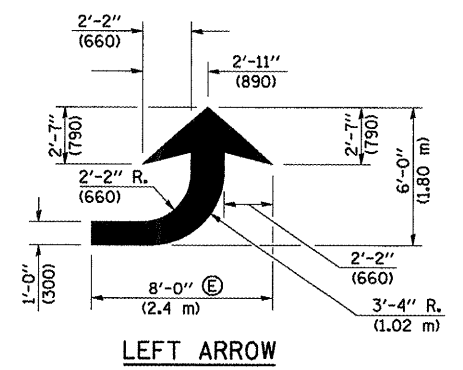

**LEFT ARROW**

REVERSE FOR RIGHT ARROW  
AREA = 15.6 SQ. FT. (1.47 m<sup>2</sup>)  
(WHITE)

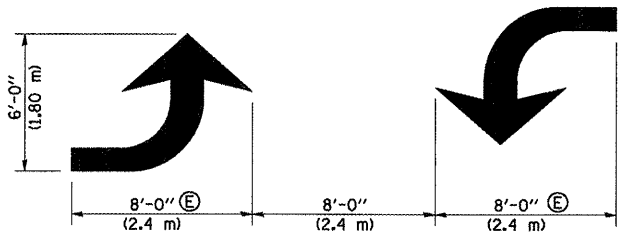

**TYPICAL DOUBLE TURN ARROWS (WHITE)**

**BLOOMINGTON-NORMAL CITY LIMITS ONLY**

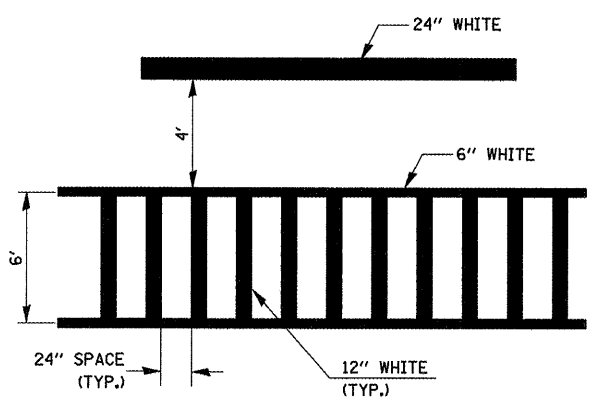

**TYPICAL SPACING FOR CROSSWALKS & STOP BARS**

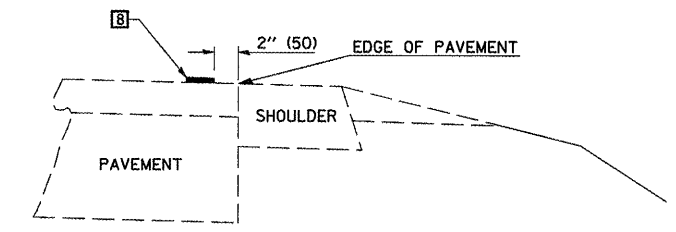

**RELATIONSHIP OF EDGE LINE TO EDGE OF PAVEMENT**  
(SAFETY SHOULDER OR PAVED SURFACE)  
SEE ARTICLE 780.04

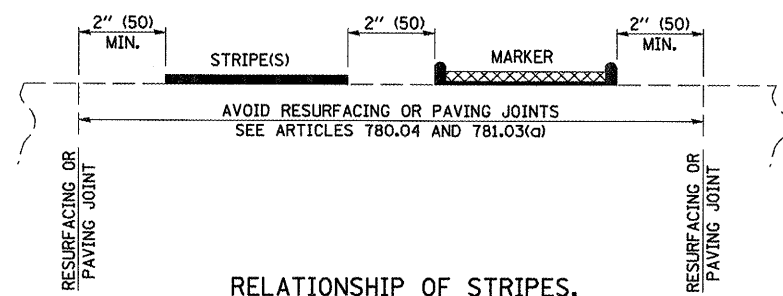

**RELATIONSHIP OF STRIPES, MARKERS AND JOINTS**

Note: All dimensions are in INCHES (millimeters) unless otherwise shown.

FILE NAME =	USER NAME = oreigre	DESIGNED -	REVISED - 11/06
ca\pwwork\pwwork\oreigre\d0112235\0570511-sht-details.dgn		DRAWN -	REVISED -
	PLOT SCALE = 40.0000' / IN.	CHECKED -	REVISED -
	PLOT DATE = 1/29/2009	DATE -	REVISED -

**STATE OF ILLINOIS  
DEPARTMENT OF TRANSPORTATION**

**PAVEMENT MARKING AND MARKERS  
(RURAL & URBAN APPLICATIONS)**

SCALE: SHEET NO. 2 OF 4 SHEETS STA. TO STA.

<b>DISTRICT 5 DETAIL NO. 7800AAAA</b>				
F.A.S. RTE.	SECTION	COUNTY	TOTAL SHEETS	SHEET NO.
1476	(55,56)RS-3	McLean	24	21
FED. ROAD DIST. NO.			ILLINOIS FED. AID PROJECT	
			CONTRACT NO. 70511	

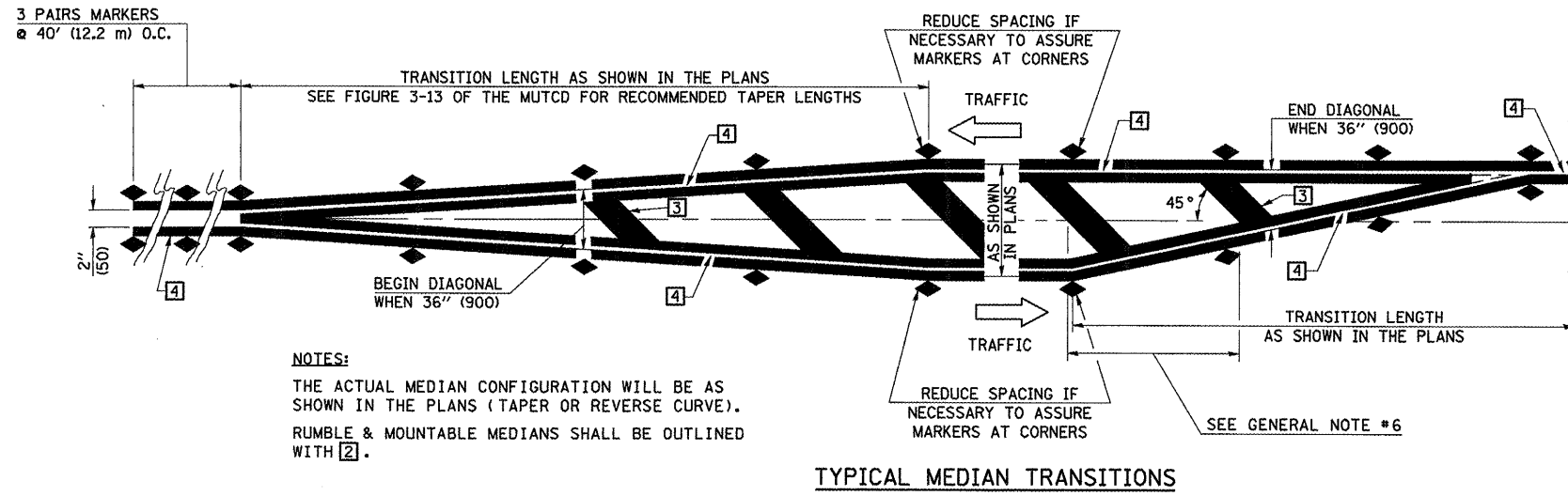

**GENERAL NOTES**

1. WHEN MEDIANS ARE PRESENT, PAVEMENT MARKINGS ARE TO BE PLACED ADJACENT TO MEDIANS.
2. SOME OF THE INFORMATION INCLUDED WITH THIS DETAIL MAY NOT BE APPLICABLE TO THIS IMPROVEMENT.
3. PAVEMENT MARKINGS ARE TO BE EXTENDED THROUGH OMISSIONS WHEN APPLICABLE.
4. A STRIPING KEY IS AVAILABLE ELSEWHERE AND SHALL BE SHOWN WHERE THE QUANTITIES ARE LISTED.
5. FINAL PAVEMENT MARKINGS SHALL BE IN PLACE PRIOR TO PLACING ANY RAISED REFLECTIVE PAVEMENT MARKERS.
6. THE FOLLOWING CRITERIA SHALL BE USED FOR SELECTING THE DIAGONAL PAVEMENT MARKING SPACING,  
 < 30 MPH USE 15' (< 50 km/h USE 4.5 m)  
 30-45 MPH USE 20' (50-75 km/h USE 6.0 m)  
 > 45 MPH USE 30' (> 75 km/h USE 9.0 m)

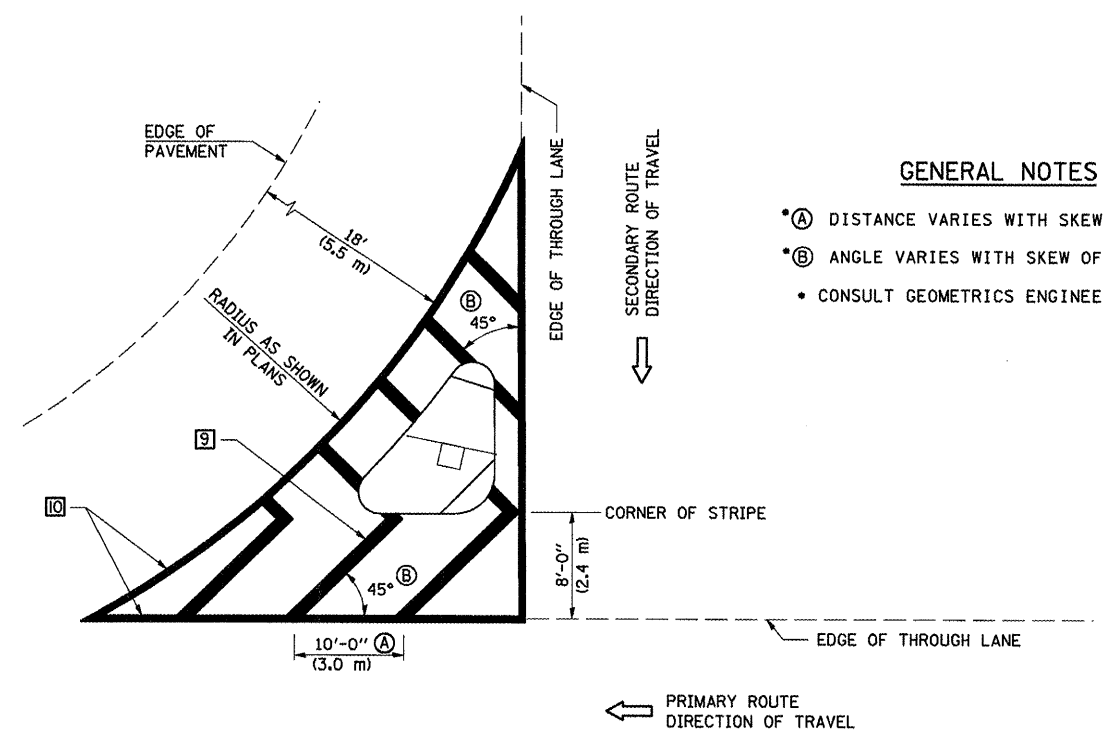
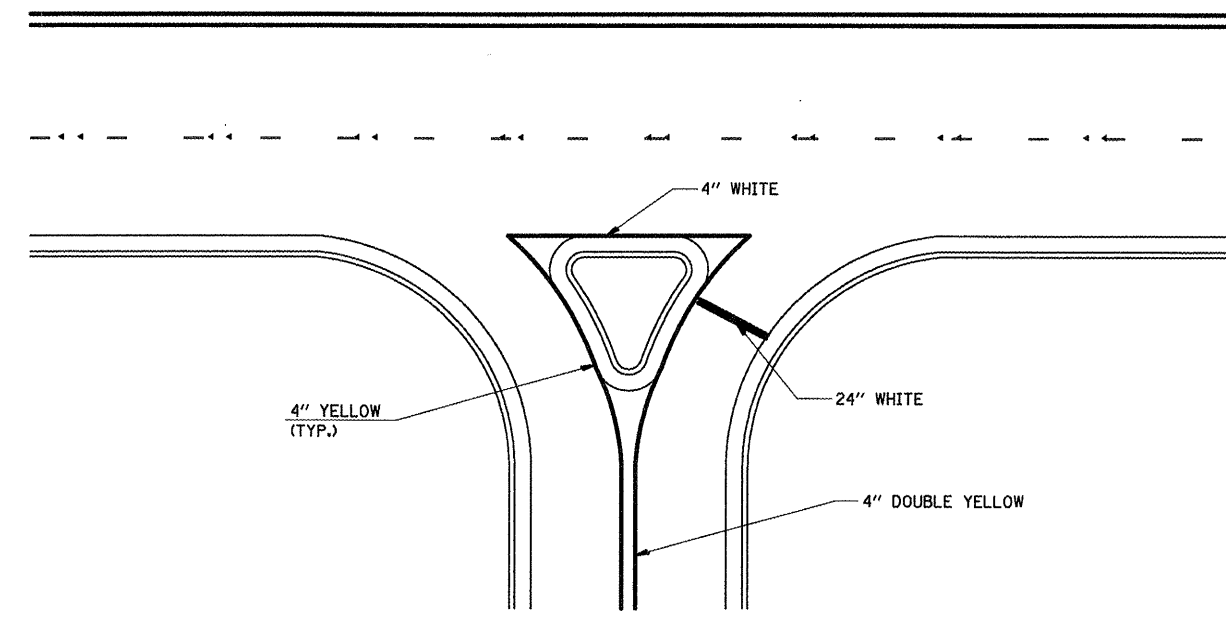

**GENERAL NOTES**

- \*A DISTANCE VARIES WITH SKEW OF INTERSECTION.
- \*B ANGLE VARIES WITH SKEW OF INTERSECTION.
- CONSULT GEOMETRICS ENGINEER

Note: All dimensions are in INCHES (millimeters) unless otherwise shown.

FILE NAME =	USER NAME = craigre	DESIGNED -	REVISED - 11/06
cr:\pwork\pvidot\craigre\d0112235\057051-1-ght-details.dgn		DRAWN -	REVISED -
	PLOT SCALE = 48.0000' / IN.	CHECKED -	REVISED -
	PLOT DATE = 1/29/2009	DATE -	REVISED -

**STATE OF ILLINOIS  
 DEPARTMENT OF TRANSPORTATION**

**PAVEMENT MARKING AND MARKERS  
 (RURAL & URBAN APPLICATIONS)**

SCALE: SHEET NO. 3 OF 4 SHEETS STA. TO STA.

DISTRICT 5 DETAIL NO. 7800AAAA				
F.A.S. RTE.	SECTION	COUNTY	TOTAL SHEETS	SHEET NO.
1476	(55,56)RS-3	McLean	24	22
FED. ROAD DIST. NO. ILLINOIS FED. AID PROJECT			CONTRACT NO. 70511	

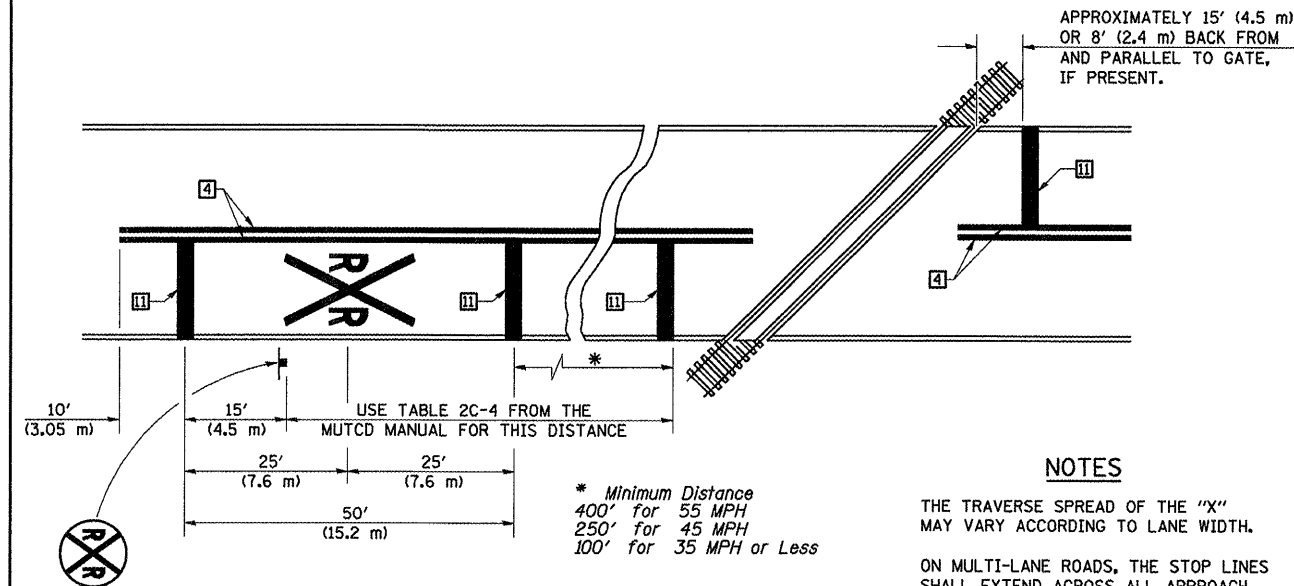

PAVEMENT MARKINGS AT RAILROAD-HIGHWAY GRADE CROSSING

NOTES

THE TRAVERSE SPREAD OF THE "X" MAY VARY ACCORDING TO LANE WIDTH.

ON MULTI-LANE ROADS, THE STOP LINES SHALL EXTEND ACROSS ALL APPROACH LANES AND SEPARATE RXR SYMBOLS SHALL BE PLACED ADJACENT TO EACH OTHER IN EACH LANE.

WHEN THE PAVEMENT MARKING SYMBOL IS USED, A PORTION OF THE SYMBOL SHOULD BE LOCATED DIRECTLY ADJACENT TO THE ADVANCE WARNING SIGN (W10-1) AS PLACED BY TABLE II-1, CONDITION B OF THE MUTCD.

RAILROAD CROSSING WITH INTERCONNECT ONLY

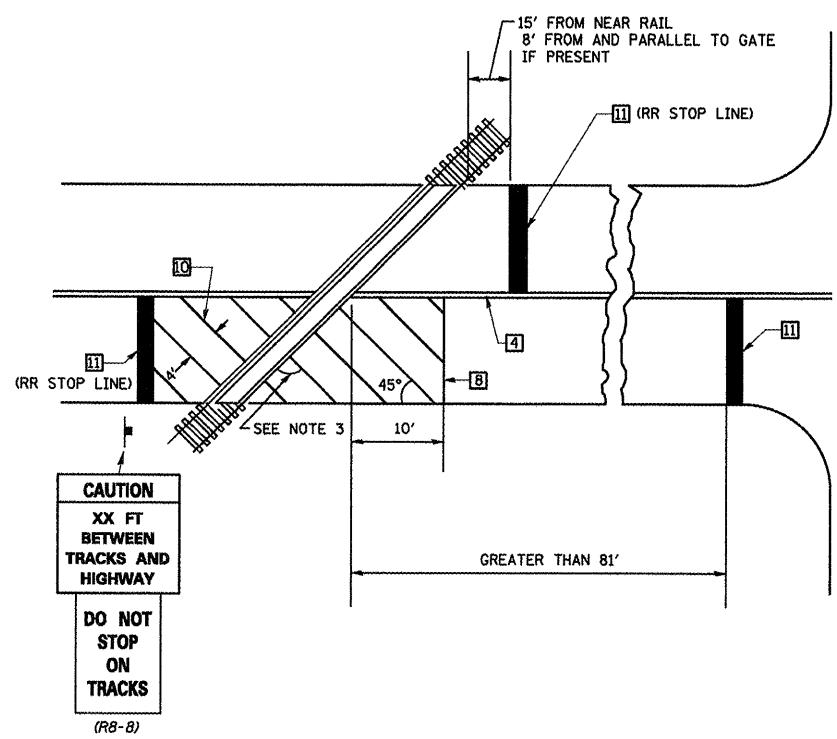

RAILROAD CROSSING WITH INTERCONNECT AND PRE-SIGNALS

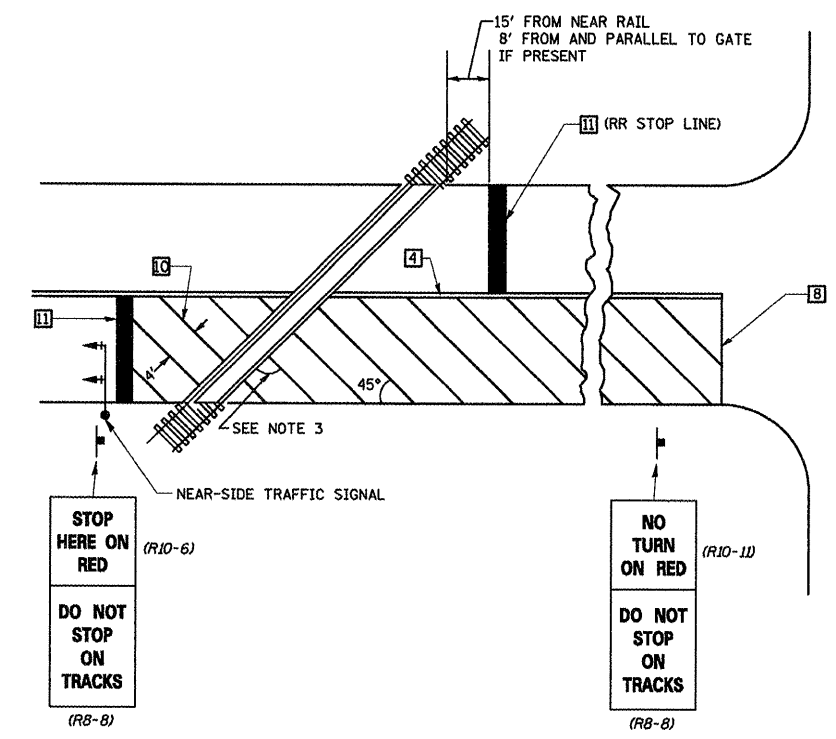

SUPPLEMENTAL PAVEMENT MARKING TREATMENT FOR RAILROAD-HIGHWAY GRADE CROSSING

GENERAL NOTES

- SUPPLEMENTAL PAVEMENT MARKINGS TO BE INSTALLED ONLY ON APPROACHES TO INTERSECTIONS CONTROLLED BY TRAFFIC SIGNALS WHICH ARE INTERCONNECTED WITH THE RAILROAD WARNING SIGNALS.
- EXTEND PAVEMENT MARKINGS TO THE INTERSECTION ONLY WHERE NEAR-SIDE TRAFFIC SIGNALS ARE USED.
- WHERE THE ANGLE BETWEEN THE DIAGONAL PAVEMENT MARKINGS AND THE TRACK WOULD BE LESS THAN 20°, THE PAVEMENT MARKINGS SHOULD BE PLACED IN THE OPPOSITE DIRECTION FROM THAT SHOWN.

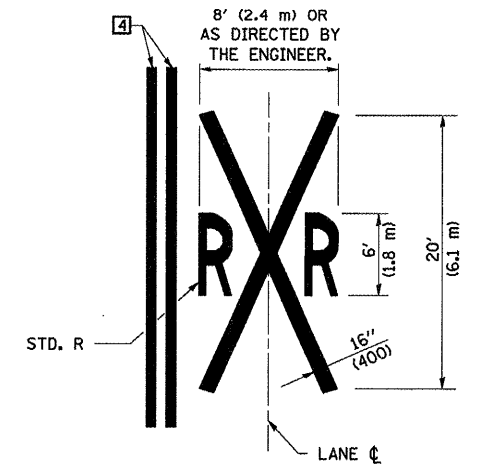

Note: All dimensions are in INCHES (millimeters) unless otherwise shown.

FILE NAME =	USER NAME = craigre	DESIGNED -	REVISED - 11/06
cr\pwork\pwork\craigre\d0112235\0570511-sht-detail.dgn		DRAWN -	REVISED -
	PLOT SCALE = 48.0000' / IN.	CHECKED -	REVISED -
	PLOT DATE = 1/29/2009	DATE -	REVISED -

STATE OF ILLINOIS  
DEPARTMENT OF TRANSPORTATION

PAVEMENT MARKING AND MARKERS  
(RURAL & URBAN APPLICATIONS)

DISTRICT 5 DETAIL NO. 7800AAAA				
F.A.S. RTE.	SECTION	COUNTY	TOTAL SHEETS	SHEET NO.
1476	(55,56)RS-3	McLean	24	23
CONTRACT NO. 70511				
FED. ROAD DIST. NO.		ILLINOIS FED. AID PROJECT		

SCALE: SHEET NO. 4 OF 4 SHEETS STA. TO STA.

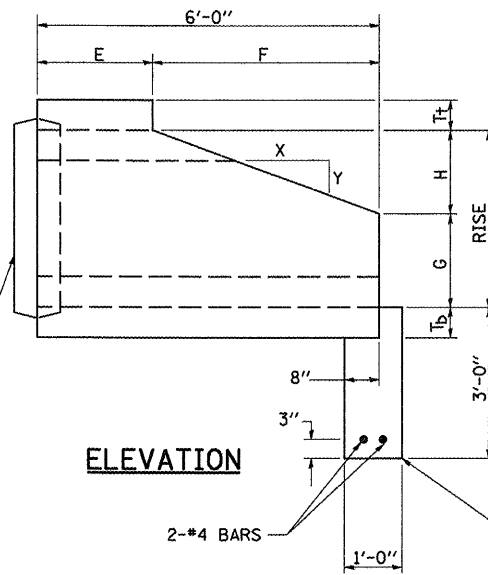

**ELEVATION**

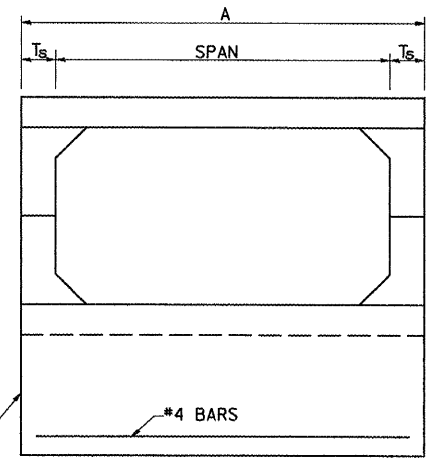

**END VIEW**

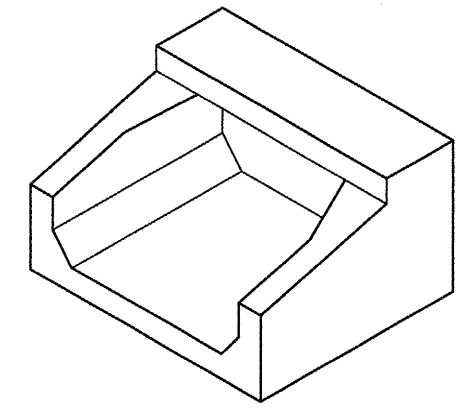

**ISOMETRIC**

END CONNECTION TO FIT PRECAST BOX CULVERT (BELL OR SPIGOT MAY BE OMITTED WHEN COLLARING TO AN EXISTING BOX OR HEADWALL.)

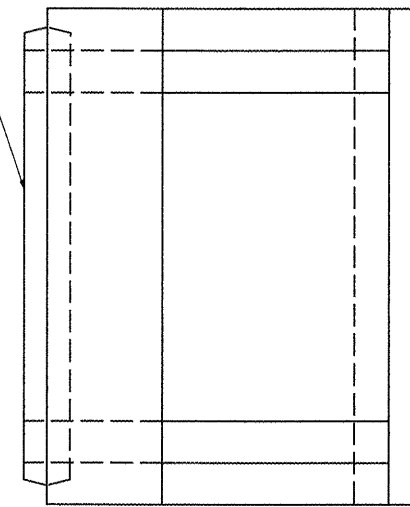

**PLAN**

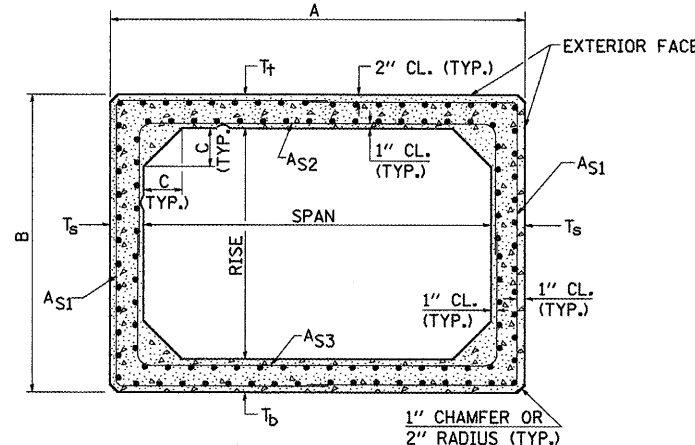

**CROSS SECTION**

**DIMENSIONS**

SPAN X RISE	T <sub>t</sub> (INCHES)	T <sub>b</sub> (INCHES)	T <sub>s</sub> (INCHES)	A (FT.-IN.)	B (FT.-IN.)	C (INCHES)	E (FT.-IN.)	F (FT.-IN.)	G (FT.-IN.)	H (FT.-IN.)	SLOPE (X:Y)
3' X 2'	7	6	4	3-8	3-1	4	3-0	3-0	1-0	1-0	3:1

**GENERAL NOTES**

SHOP DRAWINGS SHALL BE SUBMITTED IN ACCORDANCE WITH THE REQUIREMENTS OF ARTICLE 1042.03(b) OF THE STANDARD SPECIFICATIONS.

MINIMUM CONCRETE STRENGTH SHALL BE 5000 PSI AFTER 28 DAYS.

THE JOINTS OF THE PRECAST BOX SECTIONS SHALL BE SEALED WITH MASTIC IN ACCORDANCE WITH SECTION 1055 OF THE STANDARD SPECIFICATIONS FOR ROAD AND BRIDGE CONSTRUCTION.

THE TERMS AS1, AS2, & AS3 DENOTE THE REQUIRED STEEL AREAS FOR REINFORCEMENT AS SPECIFIED IN AASHTO M273. REINFORCEMENT SHALL BE WELDED WIRE FABRIC CONFORMING TO AASHTO M55-81.

Note: All dimensions are in INCHES (millimeters) unless otherwise shown.

FILE NAME =	USER NAME = craigra	DESIGNED -	REVISED -	<b>STATE OF ILLINOIS DEPARTMENT OF TRANSPORTATION</b>	<b>BOX CULVERT END SECTION (M273)</b>	F.A.S. RTE:	SECTION	COUNTY	TOTAL SHEETS	SHEET NO.	
cr:\pwork\pwork\craigra\d0112235\057051	l-ahd-detailed.dgn	DRAWN - JDC	REVISED -			1476	(55,56)RS-3	McLean	24	24	
PLOT SCALE = 48.0000' / IN.		CHECKED -	REVISED -			CONTRACT NO. 70511					
PLOT DATE = 1/29/2009		DATE - 12/29/08	REVISED -			ILLINOIS FED. AID PROJECT					