

EDGEDRAIN PLUG DETAIL

**INSPECTION HOLE REMOVAL NOTE:**

THE INSPECTION HOLES LOCATED AT STA. 140+10 & STA. 140+56 ARE CONNECTED TO THE EXISTING RCP THAT WILL REMAIN IN PLACE. THESE EXISTING INSPECTION HOLES ARE ±12 FEET TO THE TOP OF THE PIPE. THESE INSPECTION HOLES WILL BE EXCAVATED AND REMOVED JUST BELOW THE EXISTING EDGEDRAIN FLOWLINE. THE CONTRACTOR WILL SAW THE EXISTING INSPECTION HOLE COMPLETELY TO PREVENT DISTURBING THE CONNECTION WITH RCP. THE REMAINING PORTION OF THE INSPECTION HOLE WILL BE PLUGGED AND CAPPED WITH CONCRETE TO PREVENT ANY SEEPAGE TO THE SATISFACTION OF THE RESIDENT ENGINEER. ONCE CONCRETE IS SET UP, THE HOLE WILL BE BACKFILLED AND COMPACTED TO THE SATISFACTION OF THE RESIDENT ENGINEER.

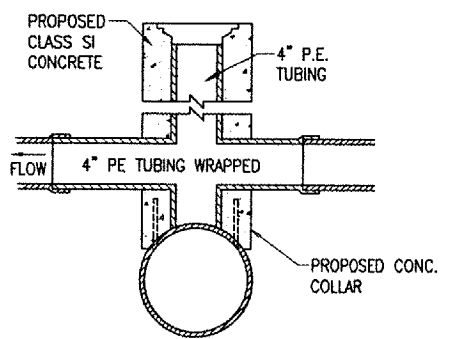
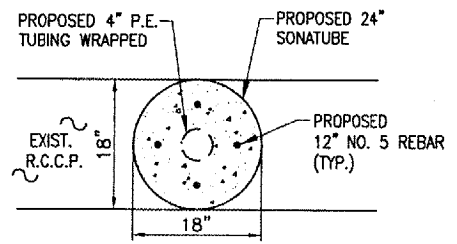

TYPE C INSPECTION HOLE DETAIL  
"NOT TO SCALE"

- LEGEND**
- EXISTING IMPROVEMENTS
  - PROPOSED IMPROVEMENTS
  - EXISTING DRAINAGE PIPE
  - EXISTING 6" UNDERDRAINS
  - EXISTING INSPECTION HOLE
  - EXISTING FLARED END SECTION
  - EXISTING UNDERDRAINS (TO BE REMOVED)
  - EXISTING INSPECTION HOLE (TO BE REMOVED)
  - PROPOSED UNDERDRAINS
  - PROPOSED INSPECTION HOLE

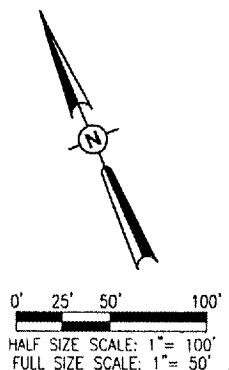

DATE	REVISION	BY

EFFINGHAM COUNTY  
MEMORIAL AIRPORT  
EFFINGHAM, ILLINOIS

IL PROJ.: 1H2-3761 A.I.P. PROJ.: 3-17-0040-811

Project No. 07A0143D 0800	FILENAME R-131DRN.DWG	DATE 02/12/08
Scale 1" = 50'	LAYOUT KDM	11/28/07
	DRAWN BAK	11/28/07
	REVIEWED CAH	02/12/08

Hanson Professional Services Inc.  
1000 W. Main Street, Suite 200  
Springfield, IL 62761  
Offices Nationwide

WIDEN RUNWAY 11/29  
AND REPLACE MRL'S  
DRAINAGE PLAN  
STA. 147+00 TO STA. 123+00

APR 09, 2008 6:34 PM HAGL000382  
I:\AIRPORTS\EFFINGHAM\07A0143\CAD\ASHEETS\R-131DRN.DWG - DRAIN 2