

TABLE 1

PAVEMENT THICKNESS T - INCHES	DEPTH OF CONTRACTION JOINT INITIAL SAW CUT I, INCHES I=(T/4) ±1/4"
5	1.25"
6	1.50"
7	1.75"
8	2.00"
9	2.25"
10	2.50"
11	2.75"
12	3.00"
13	3.25"
14	3.50"
15	3.75"
16	4.00"
17	4.25"
18	4.50"

TABLE 2

PAVEMENT THICKNESS T - INCHES	DOWEL BAR DETAILS			TIE BAR DETAILS		
	DIA.	LENGTH	SPACING	BAR SIZE	LENGTH	SPACING
5	5/8"	12"	12"	#4	24"	30"
6	3/4"	18"	12"	#5	30"	30"
7	3/4"	18"	12"	#5	30"	30"
8	1"	19"	12"	#5	30"	30"
9	1"	19"	12"	#5	30"	30"
10	1"	19"	12"	#5	30"	30"
11	1"	19"	12"	#5	30"	30"
12	1"	19"	12"	#5	30"	30"
13	1 - 1/4"	20"	15"	#5	30"	30"
14	1 - 1/4"	20"	15"	#5	30"	30"
15	1 - 1/4"	20"	15"	#5	30"	30"
16	1 - 1/4"	20"	15"	#5	30"	30"
17	1 - 1/2"	20"	18"	#5	30"	30"
18	1 - 1/2"	20"	18"	#5	30"	30"

JOINT NOTES

- 1.) ALL EDGES OF NEW SLABS, FREE STANDING OR CLOSURE, SHALL BE EDGED WITH AN APPROVED TOOL HAVING A RADIUS OF 1/8" TO 1/4" TO FACILITATE SAWING OF THE SEALANT RESERVOIR. A RADIUS > 1/4" WILL NOT BE ACCEPTABLE.
- 2.) THE INITIAL SAWCUT FOR ALL LONGITUDINAL & TRANSVERSE CONTRACTION JOINTS SHALL BE SAWED AS SOON AS POSSIBLE AFTER PLACEMENT OF THE PAVEMENT.
- 3.) ALL TIE BARS & MESH SHALL BE SECURELY HELD IN PLACE BY SUPPORT PINS OR OTHER APPROVED METHODS TO PREVENT SHIFTING DURING & AFTER CONCRETE PLACEMENT.
- 4.) TIE BARS SHALL BE DEFORMED BARS IN CONFORMANCE WITH THE SPECIFICATIONS.
- 5.) THE INITIAL SAWCUT SHALL BE MADE TO THE 1/8" WIDTH INDICATED. INITIAL SAWING TO THE DIMENSIONS OF THE SECOND SAWCUT WILL NOT BE ALLOWED.
- 6.) ALL SEALANT TO BE HOT/COLD POUR. SILICONE AND PREFORMED SEALANT SHALL NOT BE USED ON THIS PROJECT.
- 7.) ALL JOINTS THAT ARE THE END OF A CONSTRUCTION PHASE TO BE TYPE D DOWELED CONSTRUCTION JOINTS.

CONTRACTION JOINTS

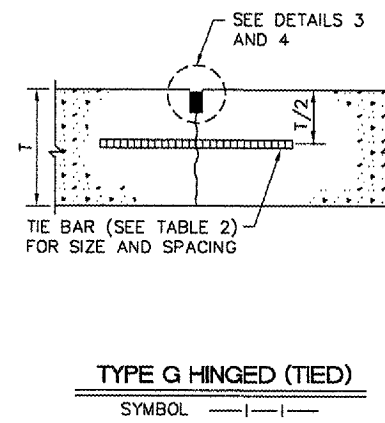
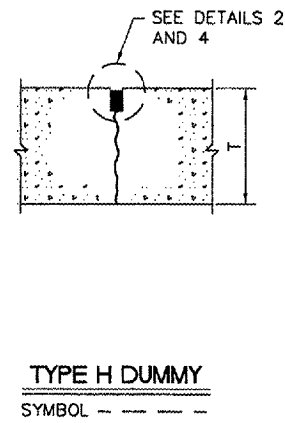
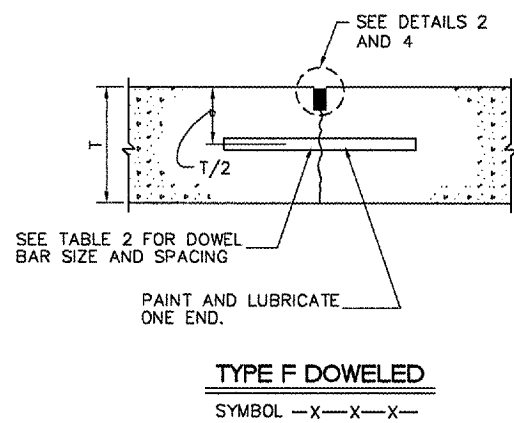

CONSTRUCTION JOINTS

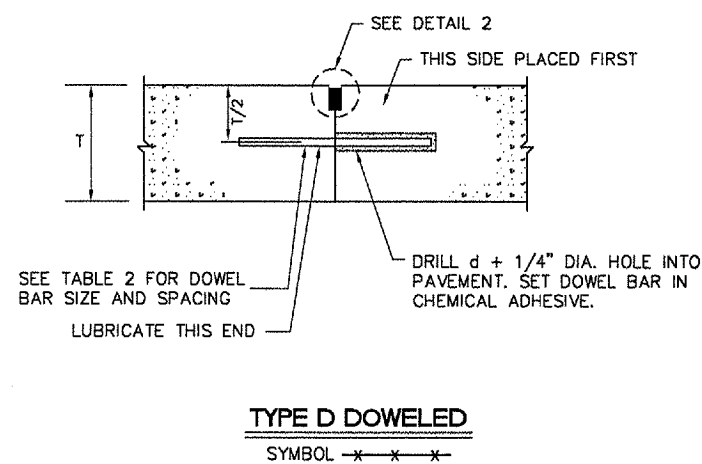

EXPANSION JOINTS

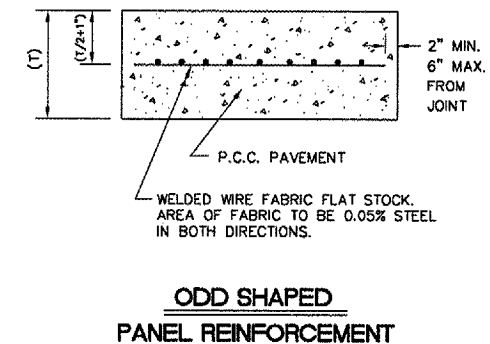
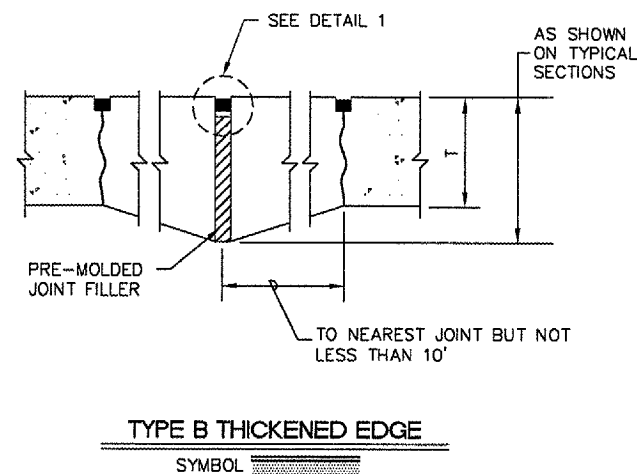

JOINT SEALING DETAILS

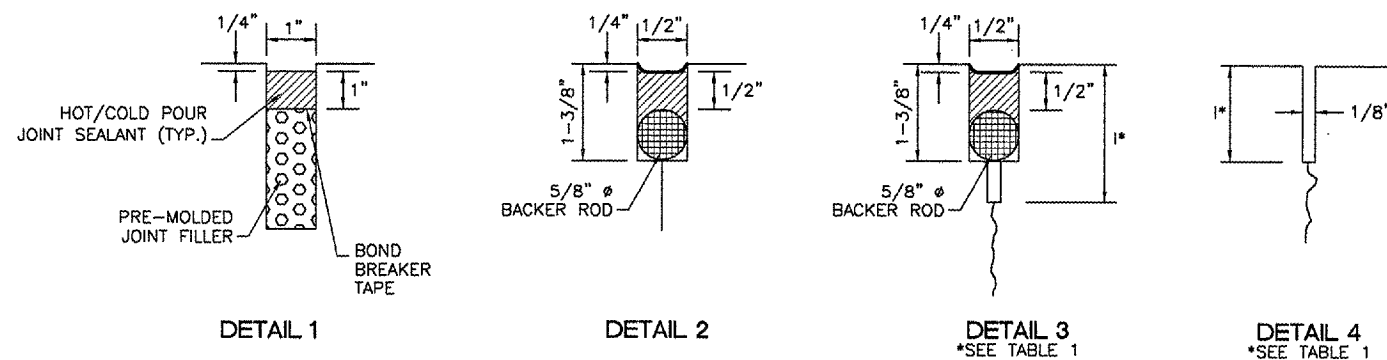

REVISIONS

NUMBER	BY	DATE

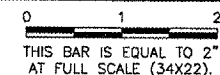

UNIVERSITY OF ILLINOIS
WILLARD AIRPORT

REHABILITATE AIR CARRIER RAMP, PHASE 2

NEW JOINTING DETAILS

© Copyright CMT, Inc.



DESIGN BY:	SMS
DRAWN BY:	CMT
CHECKED BY:	<i>SMS</i>
APPROVED BY:	<i>SMS</i>
DATE:	04/18/2008
JOB No:	0305903

CMI-3663
3-17-0016-XX