

SECONDARY GATE OPERATOR ENTRAPMENT PROTECTION CONTACT SENSORS
 N.T.S.

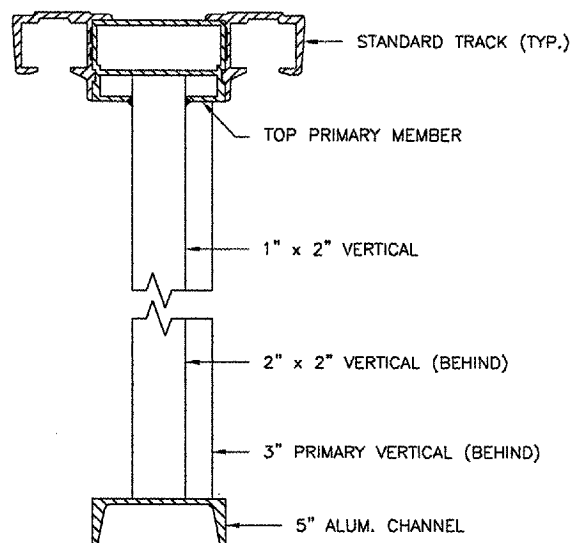

GATE FRAME SECTION
 N.T.S.

SUMMARY OF OPERATION

- 1.) THE GATES SHALL HAVE AN AUTOMATIC GATE OPERATOR WITH TWO CARD READERS AND REMOTE CONTROL. ONCE THE GATE IS OPENED IT WILL REMAIN OPEN FOR THE TIME SPECIFIED BY THE OWNER AFTER THE LOOP PICKUPS DETERMINE THAT THERE ARE NO VEHICLES OVER THE PICKUP LOOPS.
- 2.) ACTUATING THE GATE OPENERS VIA THE CARD READER REQUIRES THE VEHICLE TO APPROACH THE GATE ENTRANCE AND STOP. THE DRIVER ACTIVATES THE GATE OPENER BY SWEEPING HIS CARD. THE ACCESS CONTROL DEVICE TRANSMITS AN IMPULSE TO ACTIVATE THE GATE OPENER TO OPEN THE GATE. AFTER THE GATE IS FULLY OPENED AND STOPPED, THE VEHICLE PROCEEDS THROUGH THE OPENING, PASSING OVER THE LOOPS. WHILE THE VEHICLE IS IN THE LOOP SENSING RANGE, AN IMPULSE IS TRANSMITTED TO THE GATE OPERATOR TO HOLD THE GATE IN THE OPEN POSITION. WHEN THE LOOP HAS BEEN CLEARED, THE AUTOMATIC TIMER IS ACTIVATED AND, WHEN THE USER-DETERMINED TIME HAS ELAPSED, IT WILL ACTIVATE THE GATE OPENER TO CLOSE THE GATE. EXITING THE AREA IS ACCOMPLISHED IN THE SAME MANNER.

REVISIONS		
NUMBER	BY	DATE

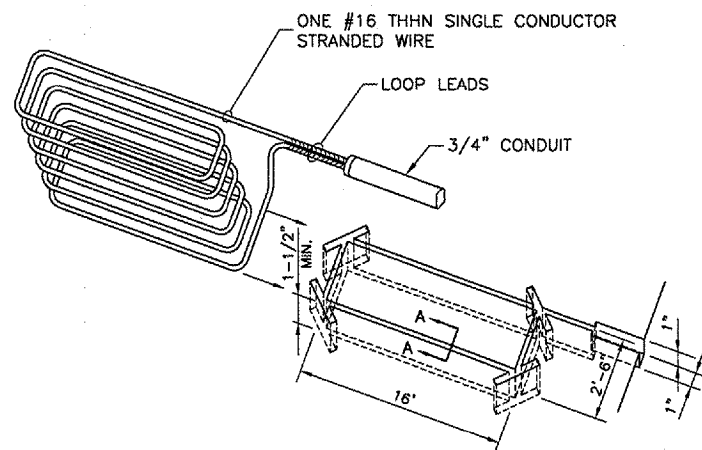
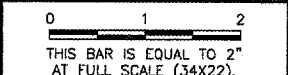

PERSPECTIVE VIEW OF DETECTOR LOOP SAW SLOT
 N.T.S.

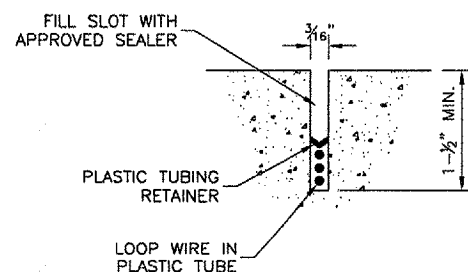

SECTION A-A
 N.T.S.

DETECTOR LOOP DETAILS

CAUTION:

- DO NOT SPLICE WIRE.
 - DO NOT FRACTURE WIRE INSULATION. LOOPS SHORTED TO GROUND WILL CAUSE DETECTOR MALFUNCTION. WHEN PLACING WIRE IN THE SLOT, DO NOT USE SCREWDRIVER OR OTHER SHARP TOOLS.
- TYPICAL LAYOUT FOR LOOP:**
- SAW SLOT 3/16" WIDE x 1-1/2" DEEP. MAKE RECTANGULAR SHAPE TO SPECIFIED LOOP DIMENSIONS PLUS SLOT FOR LEAD CONDUIT.
 - GROUT WITH NO. 202 WEATHERBAN SEALANT (A PRODUCT OF 3M CO.) OR APPROVED EQUIVALENT ... (EXAMPLE: DE WITTS NO. 99 BLACK MASTIC CAULK).

NOTES:

- 1.) LOOP LEADS ARE LIMITED TO 100 FEET.
- 2.) LOOP LEADS MUST HAVE FOUR (4) TWISTS PER FOOT.
- 3.) LOOP AND LOOP LEADS MUST BE LOCATED, AT LEAST, 18" FROM ANY ELECTRICAL POWER SERVICE OR RUN, OR STEEL REINFORCEMENT.
- 4.) LOOP LEADS MUST BE IN SEPERATE CONDUIT BETWEEN LOOP AND DETECTOR. THEY MUST NOT SHARE CONDUIT WITH OTHER WIRING OR LEADS FROM OTHER LOOPS.
- 5.) WIRE SHALL BE #16 THHN SINGLE CONDUCTOR STRANDED WIRE.
- 6.) ALL WIRE SHALL BE CONTINUOUS WITHOUT SPLICING.

NOTE:
 LOCATIONS, DETAILS AND CHARACTER OF EQUIPMENT SHOWN ON THIS SHEET ARE GENERIC. EQUIPMENT LOCATION SHALL BE AS RECOMMENDED BY THE EQUIPMENT MANUFACTURER.

SIGNS						
CONTRACTOR SHALL FURNISH AND INSTALL SIGNS AS INDICATED IN TABLE BELOW						
SIGN	DIMENSIONS	BACKGROUND		LETTERING		TEXT
		COLOR	COLOR	COLOR	HEIGHT	
1	24' x 18"	WHITE	RED	1.5"		FAA REGULATIONS REQUIRE THAT AFTER ENTERING OR EXITING THROUGH THIS SECURITY GATE YOU ARE REQUIRED TO WAIT UNTIL THE GATE CLOSES BEFORE PROCEEDING. FINES OR PENALTIES WILL BE IMPOSED.
2						SEE WARNING SIGN DETAIL

NOTES
 1) SIGNS #1 AND #3 SHALL BE INSTALLED ON BOTH SIDES OF GATE. SIGN #2 SHALL BE INSTALLED ON "LAND" SIDE OF GATE.

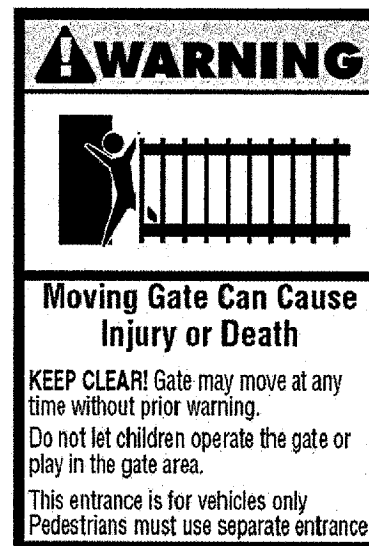

WARNING SIGN DETAIL

UL 235 COMPLIANCE NOTES

GATE INSTALLATION SHALL COMPLY WITH ALL REQUIREMENTS OF UL 235, INCLUDING, BUT NOT LIMITED TO:

1. ALL OPENINGS OF THE SLIDE GATE ARE GUARDED OR SCREENED FROM THE BOTTOM OF THE GATE TO A MINIMUM OF 4 FEET ABOVE GROUND TO PREVENT A 2-1/4" DIAMETER SPHERE FROM PASSING THROUGH THE OPENINGS ANYWHERE IN THE GATE, AND IN THAT PORTION OF THE ADJACENT FENCE THAT THE GATE COVERS IN THE OPEN POSITION.
2. ALL EXPOSED PINCH POINTS ARE ELIMINATED OR GUARDED AND GUARDING IS SUPPLIED FOR ALL EXPOSED ROLLERS.
3. A WARNING SIGN (SEE DETAIL, THIS SHEET) MUST BE AFFIXED TO BOTH SIDES OF THE SLIDE GATE.
4. FOR ADDITIONAL UL 235 REQUIREMENTS FOR THIS GATE INSTALLATION, SEE GATE OPERATOR DETAILS SHEET.

UNIVERSITY OF ILLINOIS
 WILLARD AIRPORT

REHABILITATE AIR CARRIER RAMP, PHASE 2
 ELECTRIC GATE DETAILS SHEET 2

© Copyright CMT, Inc.

CMT
 CRAWFORD, MURPHY & TILLY, INC.
 CONSULTING ENGINEERS
 License No. 984-000613



DESIGN BY:	CMT
DRAWN BY:	CMT
CHECKED BY:	<i>SMB</i>
APPROVED BY:	<i>SMB</i>
DATE:	04/18/2008
JOB No:	0305903
CMI-3663 3-17-0016-XX	
SHEET 46 OF 57 SHEETS	