

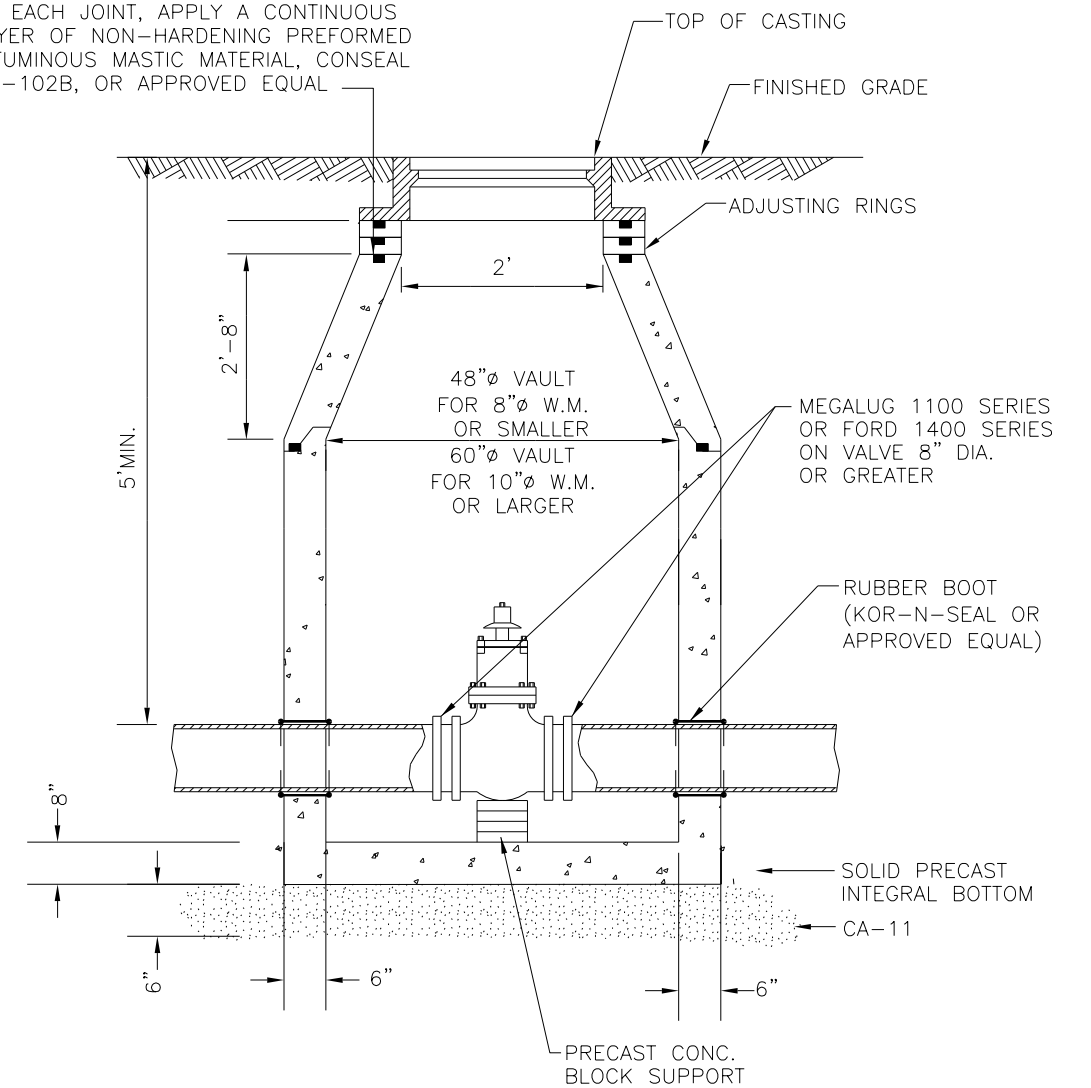

AT EACH JOINT, APPLY A CONTINUOUS LAYER OF NON-HARDENING PREFORMED BITUMINOUS MASTIC MATERIAL, CONSEAL CS-102B, OR APPROVED EQUAL



1. VALVE VAULT MUST ALIGN WITH THE CENTER OF VAULT OPENING.
2. CONCENTRIC CONES TO BE USED FOR VALVES 12" AND SMALLER.
3. VALVES SHALL BE RESILIENT WEDGE GATE VALVES WITH MECHANICAL JOINT ENDS TO COMPLY WITH ANSI/AWWA C515-09 OR LATEST VERSION VALVES TO BE CLOW, AMERICAN, WATEROUS, KENNEDY OR APPROVED EQUAL.
4. WHEN ADJUSTMENTS ARE NECESSARY, THEY SHALL BE PERFORMED WITH A MAXIMUM OF TWO (2) PRECAST CONCRETE RINGS SET IN A BED OF PREFORMED NON-HARDENING MASTIC MATERIAL (CONSEAL CS-102B OR APPROVED EQUAL) TO A MAXIMUM HEIGHT OF 12".

	CITY OF NAPERVILLE		
	DEPARTMENT OF WATER		
TITLE: VALVE VAULT			
SCALE: NTS	SECTION 500: ARTICLE 511	DATE: 10-01-12	Detail: WATER 4

DESIGNED	PJO	REVISED	-
DRAWN	KES	REVISED	-
CHECKED	JCM	REVISED	-
DATE	12/14/2012	REVISED	-

STATE OF ILLINOIS
DEPARTMENT OF TRANSPORTATION

WATER MAIN STANDARD DRAWINGS
CITY OF NAPERVILLE

SCALE: NONE SHEET NO. 2 OF 7 SHEETS STA. TO STA.

F.A.P. RTE.	SECTION	COUNTY	TOTAL SHEETS	SHEET NO.
338	(112 & 113) WRS-6	DUPAGE	734	324
WAT STD-2			CONTRACT NO. 60R31	
ILLINOIS FED. AID PROJECT				