

- 1) DUCTILE IRON SHALL BE GRADE 65-45-12 AND SHALL BE TESTED IN ACCORDANCE WITH FEDERAL SPECIFICATIONS.
- 2) ALL FRAMES AND COVERS SHALL HAVE MACHINED HORIZONTAL AND VERTICAL BEARING SURFACES. PICK HOLES SHALL NOT CREATE OPENINGS IN THE COVER.
- 3) THE MANHOLE COVERS SHALL HAVE RAISED LETTERS AS SHOWN.
- 4) ALTERNATIVE TO DUCTILE IRON LID, GRAY IRON CL 35, LID MAY BE USED.
- 5) DIMENSIONS FOR CASTINGS ARE COMPARABLE TO EAST JORDAN 1022 OR NEENAH R-1772-C, HEAVY DUTY.
- 6) LIDS AND FRAMES TO MEET AASHTO M306 PROOF LOADING SPECIFICATIONS.

		CITY OF NAPERVILLE DEPARTMENT OF WATER	
TITLE: WATER MANHOLE FRAME & COVER			
SECTION 500:	NTS	ARTICLE 512.3	10-01-12 WATER 5

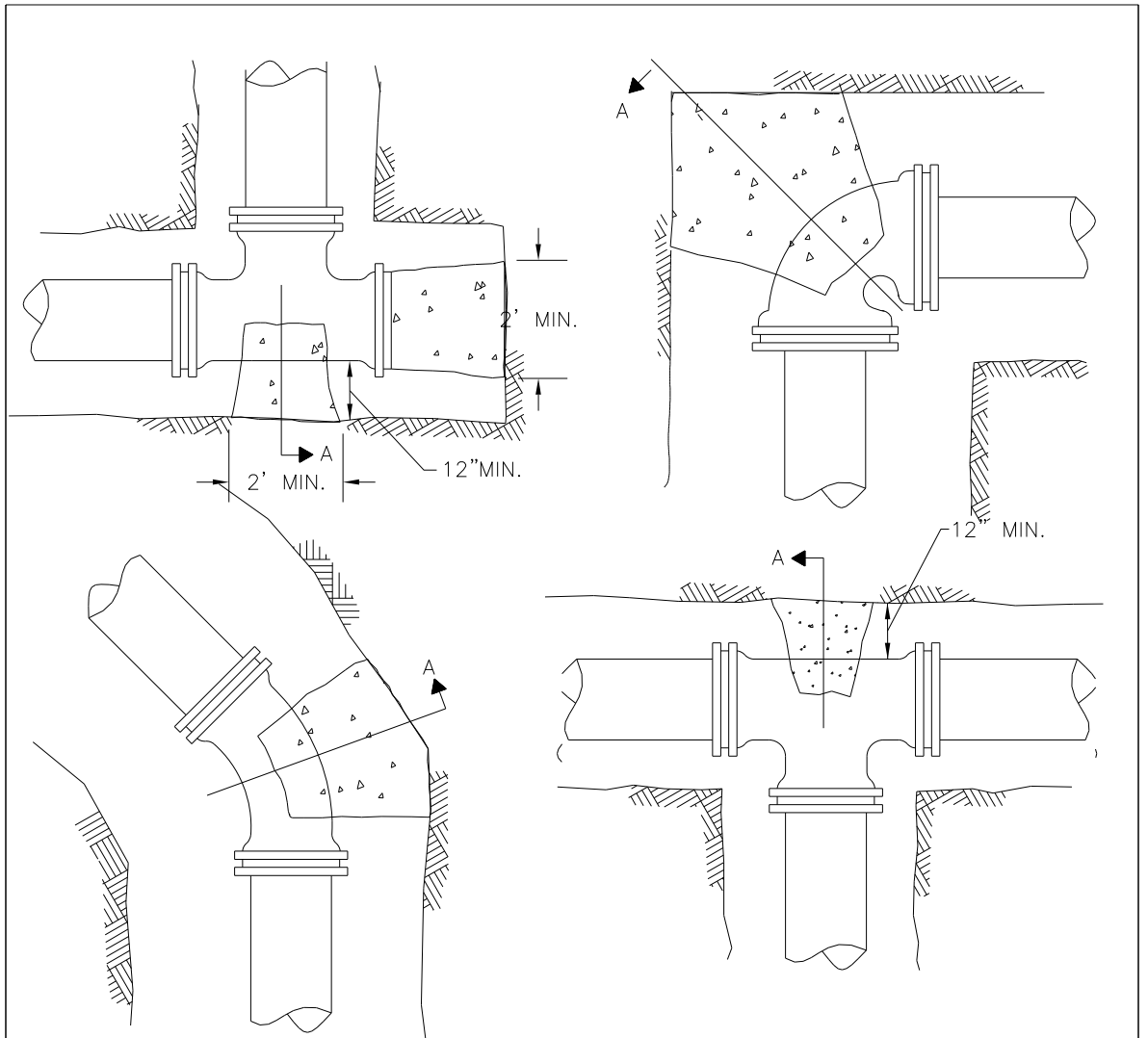

1. THRUST BLOCKING TO PREVENT MOVEMENT OF LINES UNDER PRESSURE AT BENDS, TEES, CAPS, VALVES, HYDRANTS, & AT POINTS SPECIFIED BY THE ENGINEER SHALL BE CLASS "SI".
2. CONCRETE A MINIMUM OF 12" THICK, PLACED BETWEEN SOLID GROUND & THE FITTING, AND SHALL BE ANCHORED IN SUCH A MANNER THAT THE PIPE AND FITTING WILL BE ACCESSIBLE FOR REPAIRS.
3. THRUST BLOCKS SHALL BE PLACED AT BENDS OF 11-1/4' OR MORE.
4. PIPE BENDS TO BE POLYETHYLENE ENCASED.
5. JOINT RESTRAINT AT BEND AND REQUIRED LENGTH OF PIPE EACH DIRECTION FROM BENDS AS REQUIRED BY THE CITY OF NAPERVILLE IF UNDISTURBED SOIL NOT AVAILABLE.
6. THRUST BLOCK FOR PIPES LARGER THAN 12"Ø MUST BE POURED IN PLACE

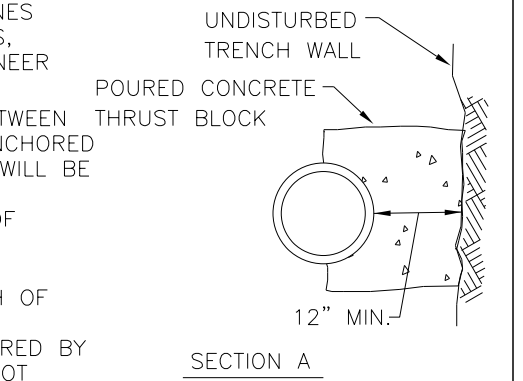

		CITY OF NAPERVILLE DEPARTMENT OF WATER	
TITLE: THRUST BLOCK INSTALLATION			
SECTION 500:	NTS	ARTICLE 506.5	10-01-12 WATER 6