

EXISTING TYPICAL SECTION

EASTBOUND	WESTBOUND
STA. 515+61 TO STA. 533+84	STA. 515+66 TO STA. 522+89
STA. 557+23 TO STA. 580+36	STA. 560+37 TO STA. 577+02
STA. 589+51 TO STA. 617+50	STA. 582+83 TO STA. 590+00
* STA. 607+50 TO STA. 617+20	* STA. 587+00 TO STA. 590+00

* TRANSITIONS FROM 26' - 38' WIDTH

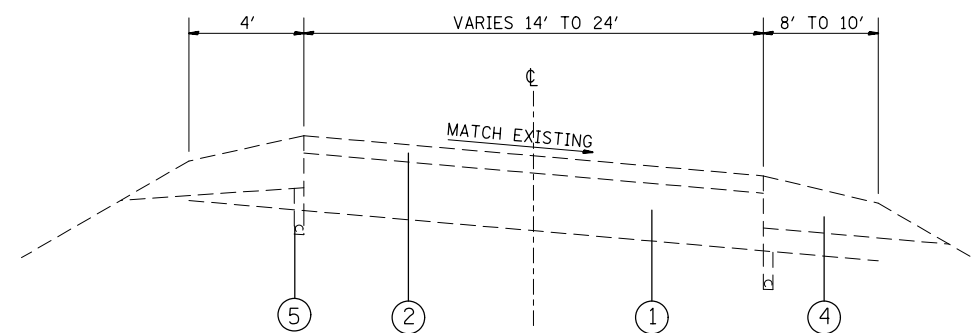

EXISTING RAMP SECTION

IL 157 RAMP 1 - STA. 146+97 TO STA. 153+93
 IL 157 RAMP 2 - STA. 257+22 TO STA. 274+33
 IL 157 RAMP 3 - STA. 6+21 TO STA. 13+95
 IL 157 RAMP 4 - STA. 1+33 TO STA. 10+20
 IL 159 RAMP 1 - STA. 2+37 TO STA. 10+18
 IL 159 RAMP 2 - STA. 5+56 TO STA. 14+18
 IL 159 RAMP 3 - STA. 14+61 TO STA. 17+26
 IL 159 RAMP 4 - STA. 2+37 TO STA. 9+73

LEGEND

- ① EXISTING SUB-BASE GRANULAR MATERIAL
- ② EXISTING PCC PAVEMENT, 10"
- ③ EXISTING HOT-MIX ASPHALT OVERLAY
- ④ EXISTING HOT-MIX ASPHALT SHOULDER
- ⑤ EXISTING UNDERDRAIN
- ⑥ PROPOSED MICRO-SURFACING, SINGLE PASS, TYPE II, MIX E
- ⑦ PROPOSED ULTRA-THIN HMA SURFACE COURSE, 1/2"
- ⑧ PROPOSED RAPID SETTING POLYMER MODIFIED EMULSION
- ⑨ PROPOSED THERMOPLASTIC PAVEMENT MARKING

FILE NAME =	USER NAME = burnsideem	DESIGNED -	REVISED -	STATE OF ILLINOIS DEPARTMENT OF TRANSPORTATION	TYPICAL SECTIONS				F.A.I. RTE.	SECTION	COUNTY	TOTAL SHEETS	SHEET NO.	
et:\pwork\pwork\burnsideem\d0298717\d0298717\4876f86-shr-plan.dgn		DRAWN -	REVISED -		SCALE:	SHEET NO.	OF SHEETS	STA.	TO STA.	270	60-(4,5)-1RS-4	MADISON	42	7
		CHECKED -	REVISED -						CONTRACT NO. 76F86					
		DATE -	REVISED -		FED. ROAD DIST. NO. ILLINOIS FED. AID PROJECT									