

LEGEND

- ① EXISTING HMA OVERLAY
- ② EXISTING PCC BASE COURSE, 10"
- ③ EXISTING CONCRETE CURB AND GUTTER, B-6.12 TO BE REMOVED (STA. 98+00 TO STA. 101+60)
- ④ EXISTING PCC SIDEWALK, 5" TO BE REMOVED (STA. 98+00 TO STA. 101+60)
- ⑤ EXISTING PPC DECK BEAMS
- ⑥ EXISTING HMA WEARING SURFACE (2")
- ⑦ EXISTING PARAPET WALLS
- ⑧ PROPOSED PCC SIDEWALK, 5" (PAID AS CONCRETE SUPERSTRUCTURE)
- ⑨ PROPOSED HMA SURFACE REMOVAL, 3"
- ⑩ PROPOSED HMA SURFACE CSE., MIX "D", N70, 1 1/2"
- ⑪ PROPOSED HMA BINDER COURSE, IL-19.0, N70, 2 1/4"
- ⑫ PROPOSED COMBINATION CONCRETE CURB AND GUTTER, B-6.12 REDUCE SPACE REPLACEMENT
- ⑬ PROPOSED PCC SIDEWALK, 5" REPLACEMENT
- ⑭ PROPOSED COMPOST FURNISH AND PLACE, 4", WITH SEEDING, CLASS 4
- ⑮ PROPOSED PPC DECK BEAMS (11" DEPTH)
- ⑯ PROPOSED PARAPET WALL (PAID AS CONCRETE SUPERSTRUCTURE)
- ⑰ PROPOSED CONCRETE WEARING SURFACE, 5"

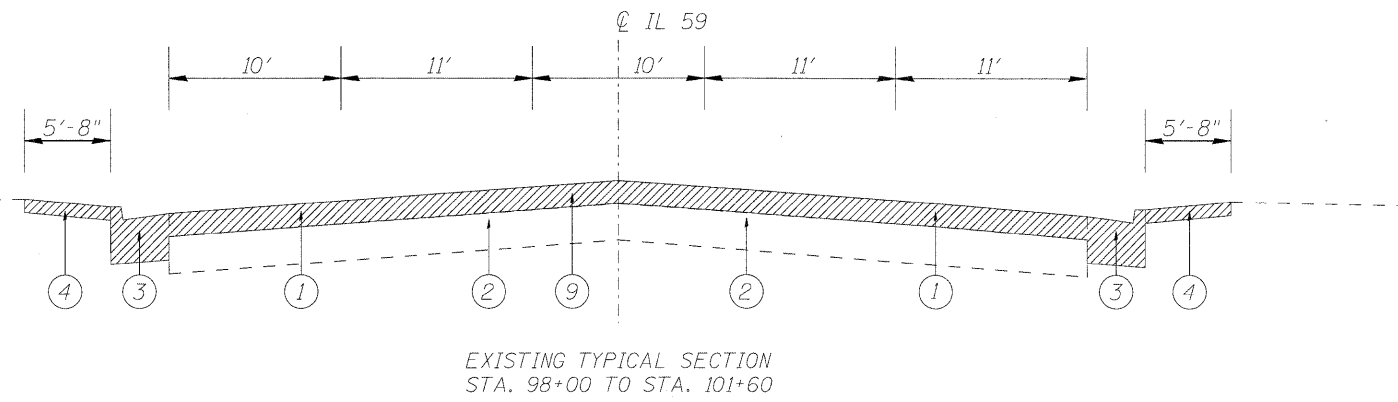

EXISTING TYPICAL SECTION
STA. 98+00 TO STA. 101+60

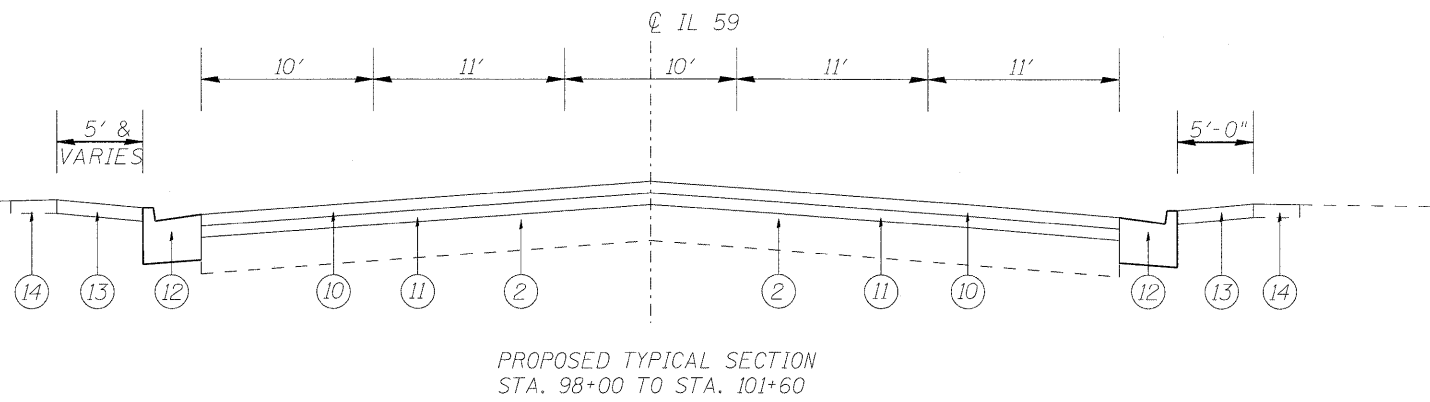

PROPOSED TYPICAL SECTION
STA. 98+00 TO STA. 101+60

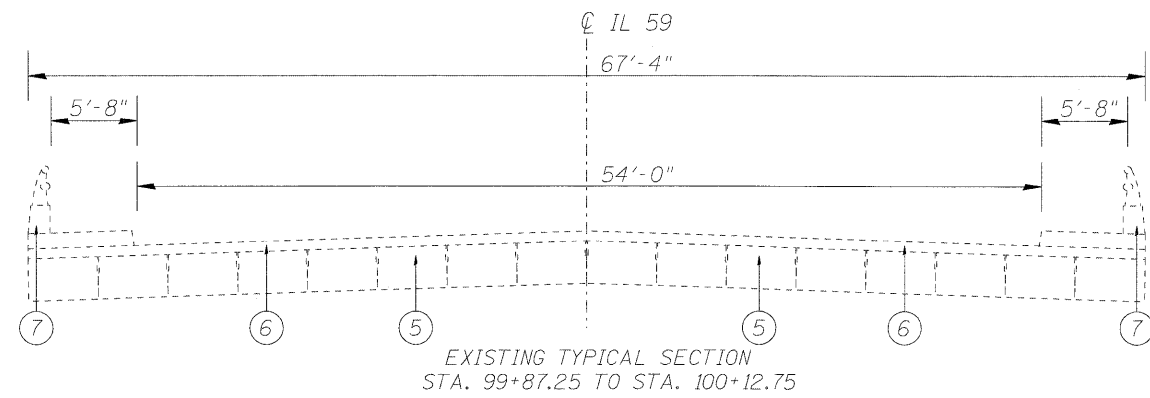

EXISTING TYPICAL SECTION
STA. 99+87.25 TO STA. 100+12.75

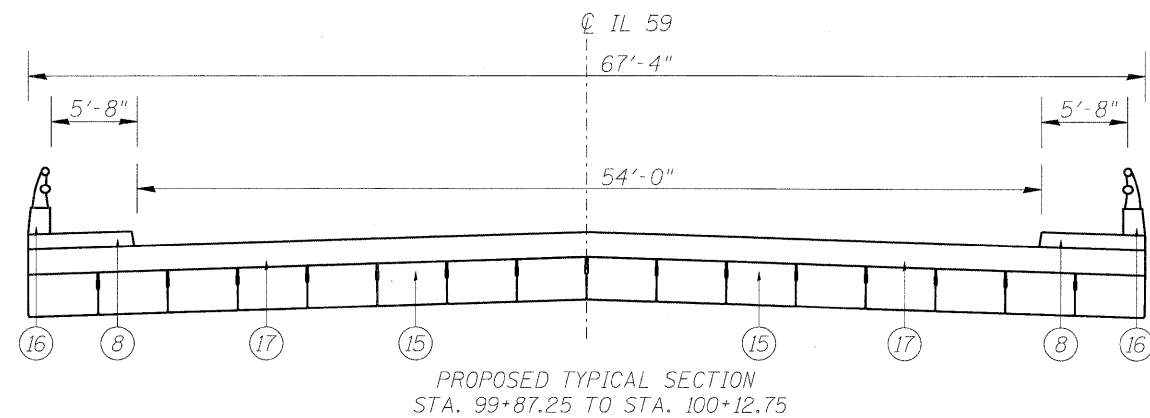

PROPOSED TYPICAL SECTION
STA. 99+87.25 TO STA. 100+12.75

HOT-MIX ASPHALT MIXTURE REQUIREMENTS		
OPERATION	MIXTURE TYPE	DESIGN AIR VOIDS
ROADWAY	HMA SURFACE COURSE, MIX "D", N70 (IL-9.5 mm)	4% @ 70 GYR
	HMA BINDER COURSE, IL-19.0, N70	4% @ 70 GYR
	CLASS D PATCH (HMA BINDER IL-19 mm)	4% @ 70 GYR
	HMA REPLACEMENT OVER PATCHES (HMA BINDER IL-19 mm)	4% @ 70 GYR
BRIDGE APPROACH PAVEMENT CONNECTOR FLEXIBLE, 15"	HMA SURFACE COURSE, MIX "D", N70 (IL-9.5 mm), 2"	4% @ 70 GYR
	HMA BINDER COURSE, IL-19.0, N70, 13"	4% @ 70 GYR
DRIVEWAY	HMA SURFACE COURSE, MIX "C", N50 (IL-9.5 mm), 2"	4% @ 50 GYR
	HMA BASE COURSE (HMA BINDER IL-19.0), 4"	4% @ 50 GYR

NOTES:

THE UNIT WEIGHT USED TO CALCULATE ALL HMA SURFACE COURSE MIXTURES IS 112 LBS/SQ-YD/IN.

THE CONTRACTOR SHALL PATCH FIRST BEFORE MILLING

FOR "AC TYPE" FOR POLYMERIZED HMA MIXES SHALL BE "SBS/SBR PG 70 -22" AND FOR NON-POLYMERIZED HMA THE "AC TYPE" SHALL BE "PG 64 -22" UNLESS MODIFIED BY DISTRICT ONE SPECIAL PROVISIONS. FOR "PERCENT OF RAP" SEE DISTRICT ONE SPECIAL PROVISIONS.