

STATE OF ILLINOIS
DEPARTMENT OF TRANSPORTATION

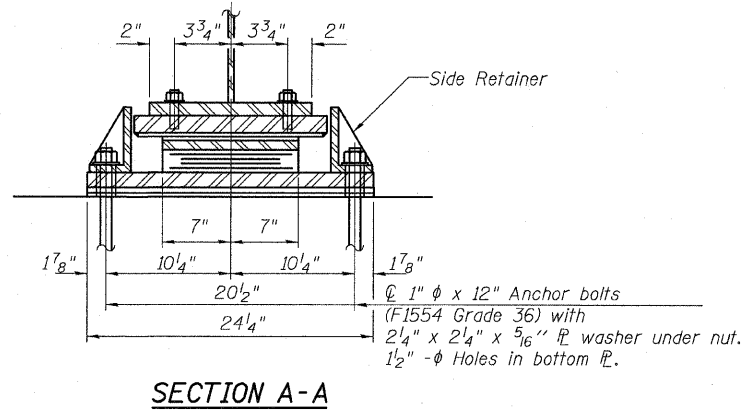

TYPE II ELASTOMERIC EXP. BRG. AT W. ABUT.

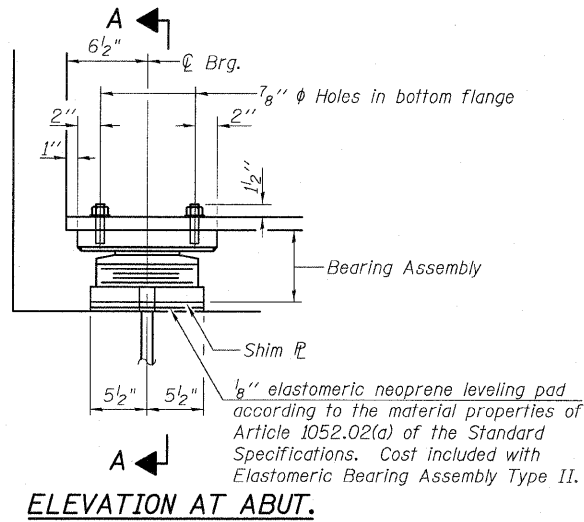
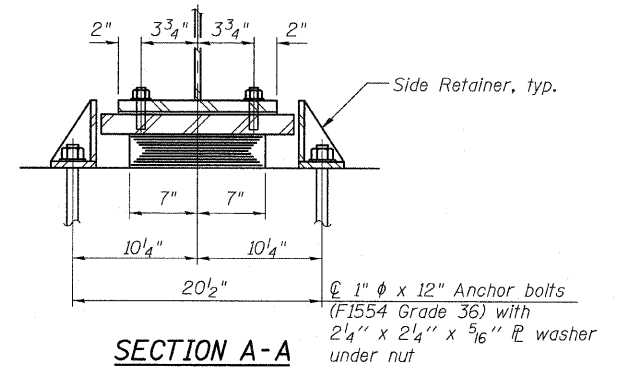
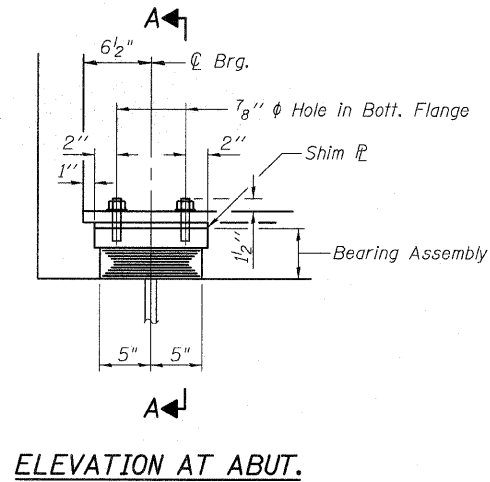

TYPE I ELASTOMERIC EXP. BRG. AT E. ABUT.

Notes for Type I and Type II bearings this sheet:
Anchor bolts shall be ASTM F1554 all-thread (or an Engineer-approved alternate material) of the grade(s) and diameter(s) specified. ASTM A307 Grade C anchor bolts may be used in lieu of ASTM F1554 Grade 36 (Fy=36ksi). The corresponding specified grade of AASHTO M314 anchor bolts may be used in lieu of ASTM F1554.
Anchor bolts for Type II bearings shall be placed in holes drilled in the concrete through holes in the bottom bearing plate after members are in place. Side retainers shall be placed after bolts are installed.
Anchor bolts for Type I bearings may be cast in place or installed in holes drilled before or after members are in place. Drilled and set anchor bolts shall be installed according to Article 521.06 of the Standard Specifications.
Side retainers and other steel members required for the bearing assembly shall be included in the cost of Elastomeric Bearing Assembly, Type II or Elastomeric Bearing Assembly, Type I.
For Type II bearings, the 1/8 inch PTFE sheet shall be bonded directly to the top steel plate with a two-component, medium viscosity epoxy resin, conforming to the requirements of the Federal Specification MMM-A-134, Type I. The bond agent shall be applied on the full area of the contact surfaces.
For Type II bearings, bonding of 1/8 inch PTFE sheet during vulcanizing process will be permitted provided the process and method of adjusting assembly height is approved by the Engineer.
H.S. Bolts shall be galvanized according to AASHTO M298, class 50.
Two 1/8 inch adjusting shims shall be provided for each bearing in addition to all other plates or shims and placed as shown on bearing details.

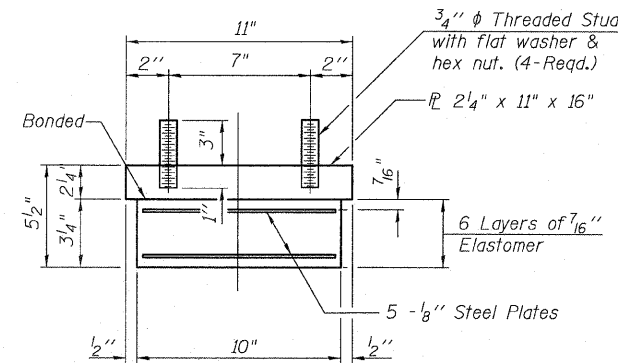
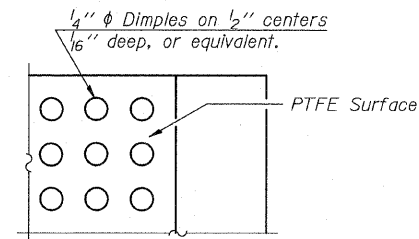
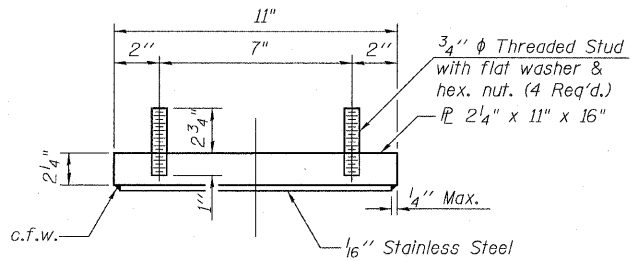

BEARING ASSEMBLY

Note:
Shim plates shall not be placed under Bearing Assembly.

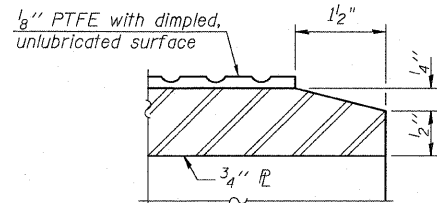
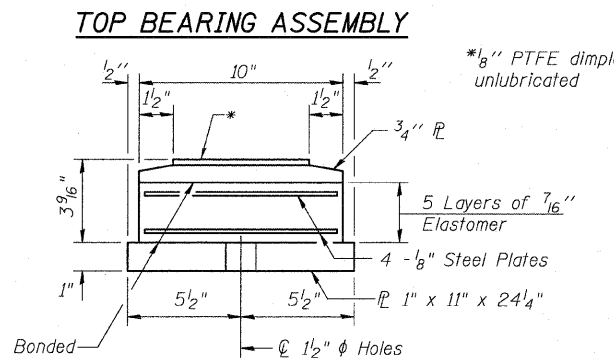

SECTION THRU PTFE

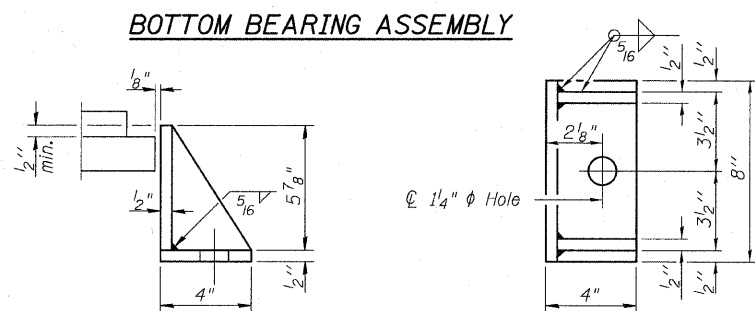

Equivalent rolled angle with stiffeners will be allowed in lieu of welded plates.

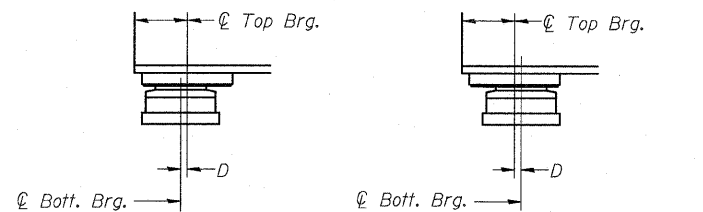

BELOW 50°F. (Move bott. brg. away from fixed brg.) ABOVE 50°F. (Move bott. brg. toward fixed brg.)

SETTING ANCHOR BOLTS AT EXP. BRG.

D=1/8 inch per each 100 feet of expansion for every 15 degrees temp. change from the normal temp. of 50°F.

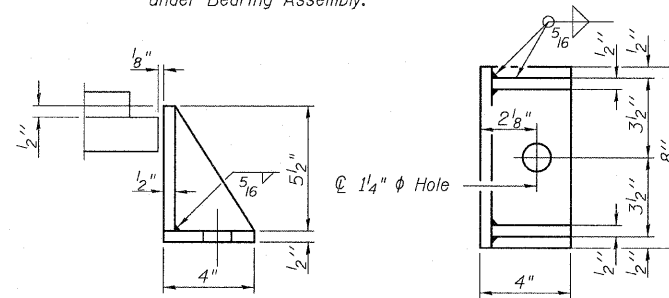

Equivalent rolled angle with stiffeners will be allowed in lieu of welded plates.

BILL OF MATERIAL

Item	Unit	Total
Elastomeric Bearing Assembly Type II	Each	31
Elastomeric Bearing Assembly Type I	Each	31
Anchor Bolts, 1"	Each	124

**BEARINGS-ABUTMENTS
STRUCTURE NO. 016-1251**

TYLIN INTERNATIONAL

DESIGNED - JMA	REVISIONS	
CHECKED - SP.	NAME	DATE
DRAWN - JMA		
CHECKED - SP,PDF		
DATE - 03/18/10		

SHEET NO. 41	F.A.I RTE. 57	SECTION	COUNTY	TOTAL SHEETS	SHEET NO.
		1414.2B	COOK	516	286
68 SHEETS		CONTRACT NO. 60J27			
FED. ROAD DIST. NO. 1 ILLINOIS FED. AID PROJECT					

P:\602540167-294\STRUCTURAL\1-57-OVER_1294\0161251-60J27-041-BRG-ABUT.dgn

3/17/2010