

ROUTE VARIOUS	SECTION 2010-023 BP	COUNTY VARIOUS	TOTAL SHEETS 93	SHEET NUMBER 41
------------------	------------------------	-------------------	--------------------	--------------------

CONTRACT NO. 60K48

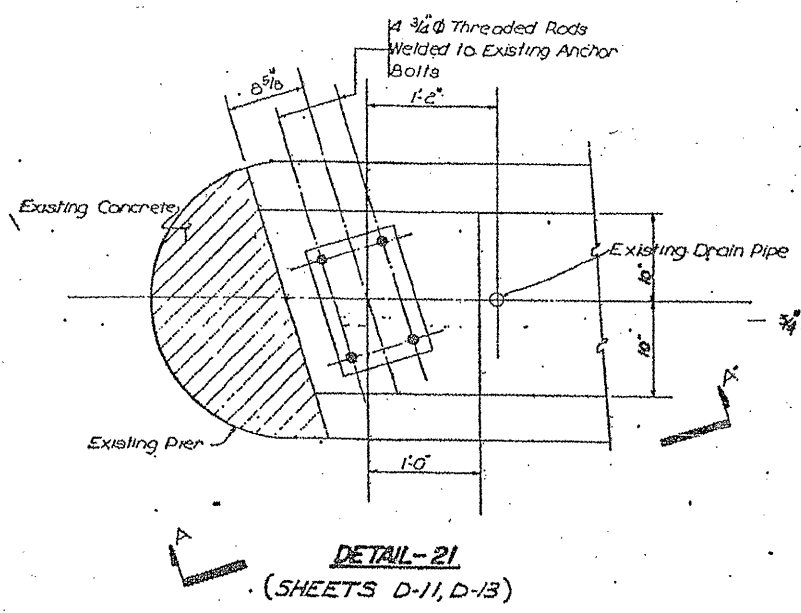

DETAIL-21
(SHEETS D-11, D-13)

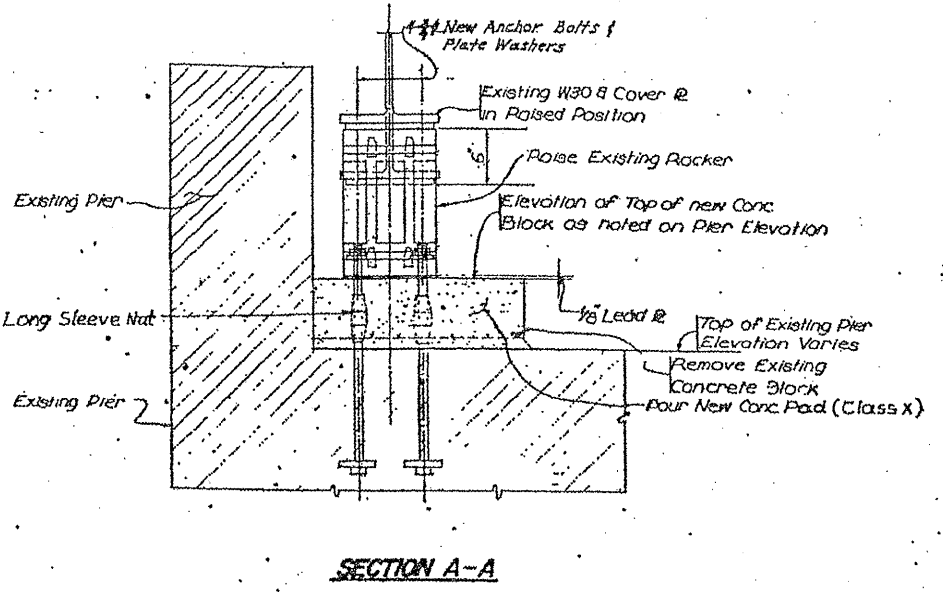

SECTION A-A

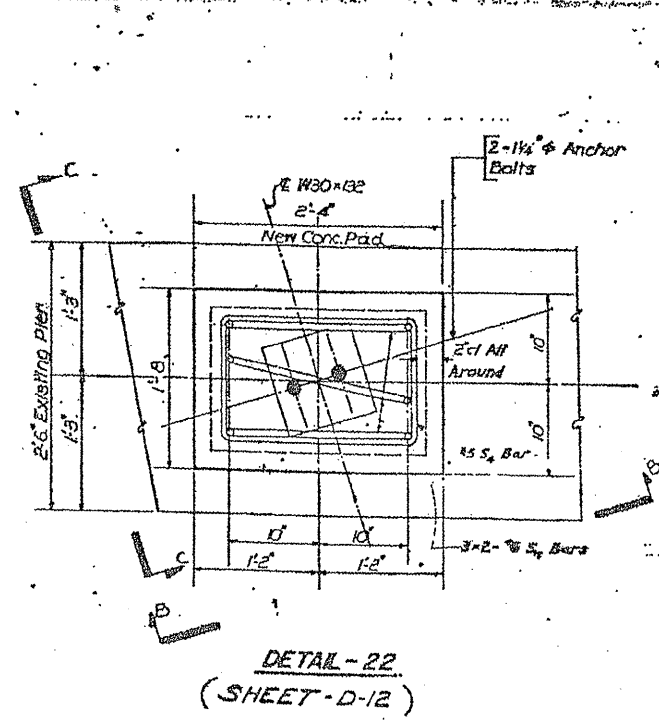

DETAIL-22
(SHEET D-12)

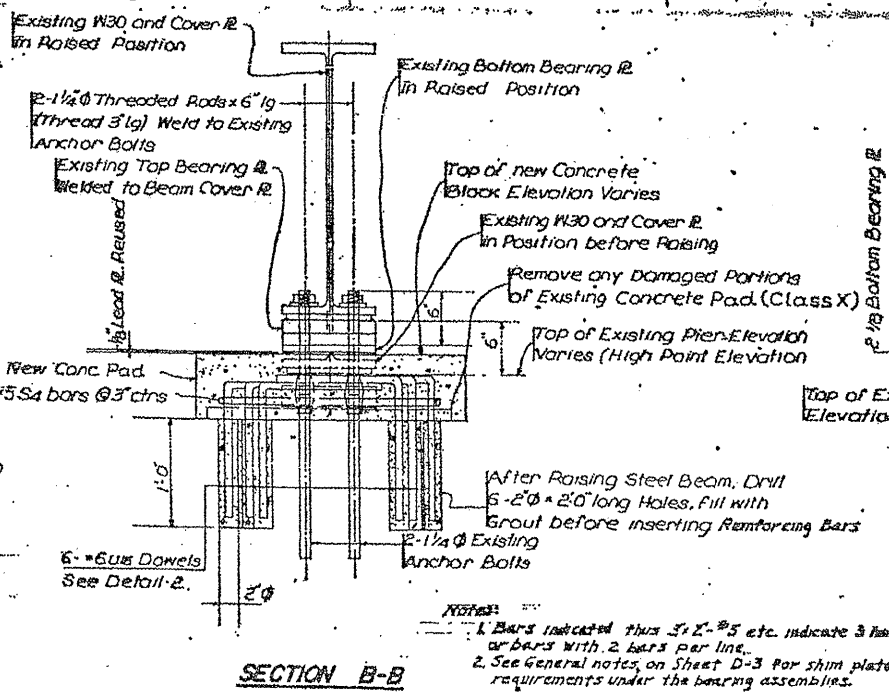

SECTION B-B

Notes:
1. Bars indicated thus 3-2-#5 etc. indicate 3 lines or bars with 2 bars per line.
2. See General notes on Sheet D-3 for shim plate requirements under the bearing assemblies.

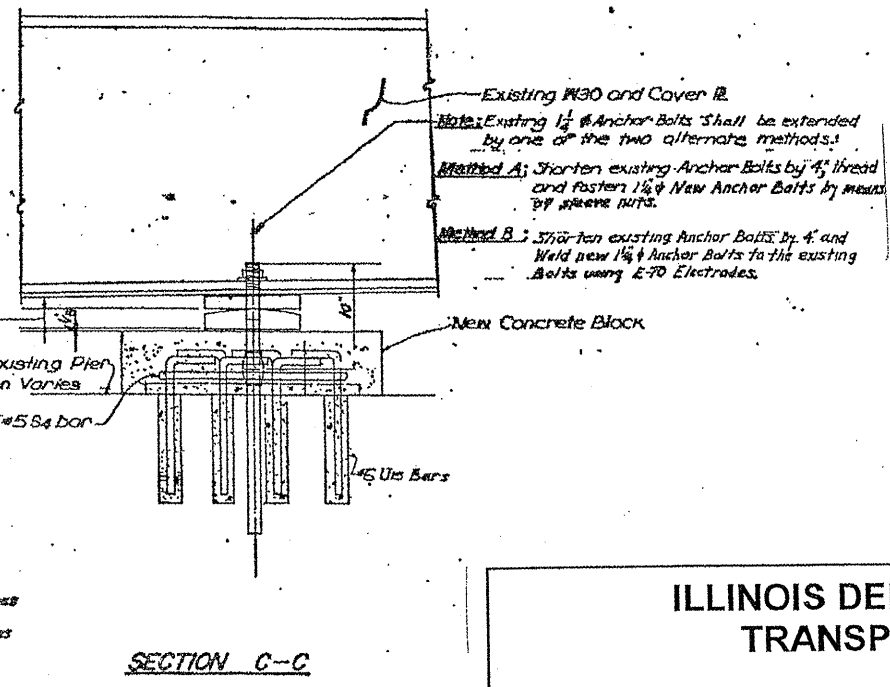

SECTION C-C

ILLINOIS DEPARTMENT OF
TRANSPORTATION

EXISTING BRIDGE PLAN

LOCATION 7: SN 016-0834
DEVON AVE. OVER I-94

SH. 5 of 6