

STATE OF ILLINOIS
DEPARTMENT OF TRANSPORTATION

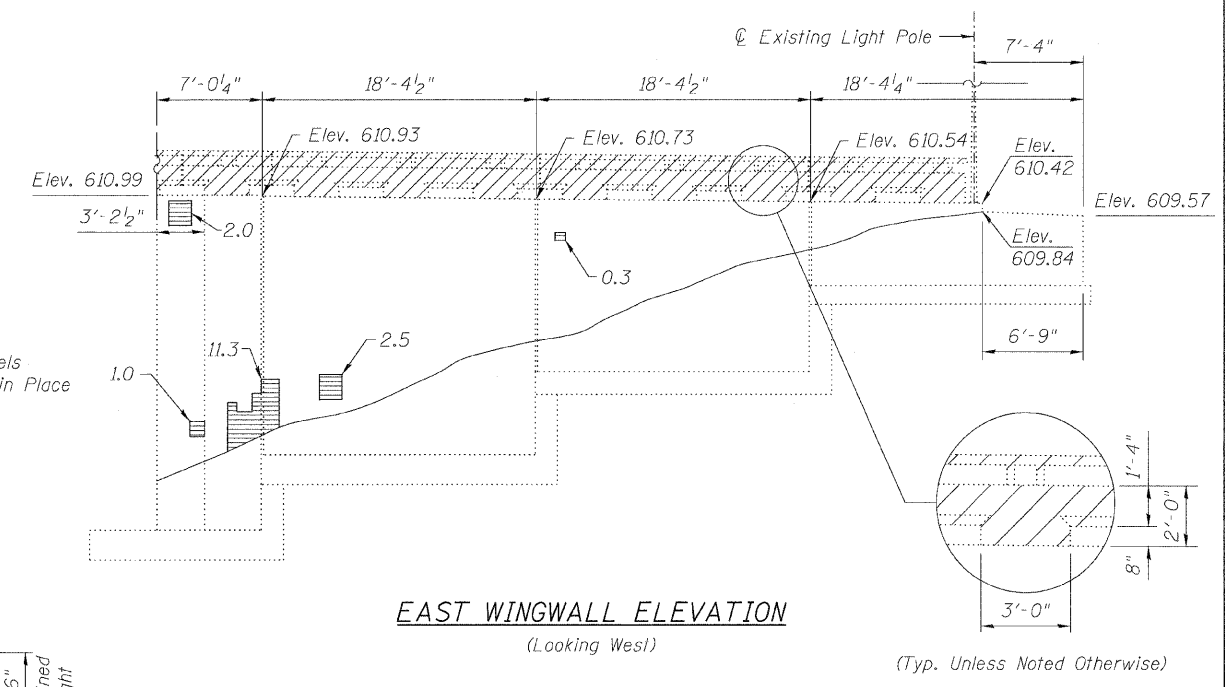
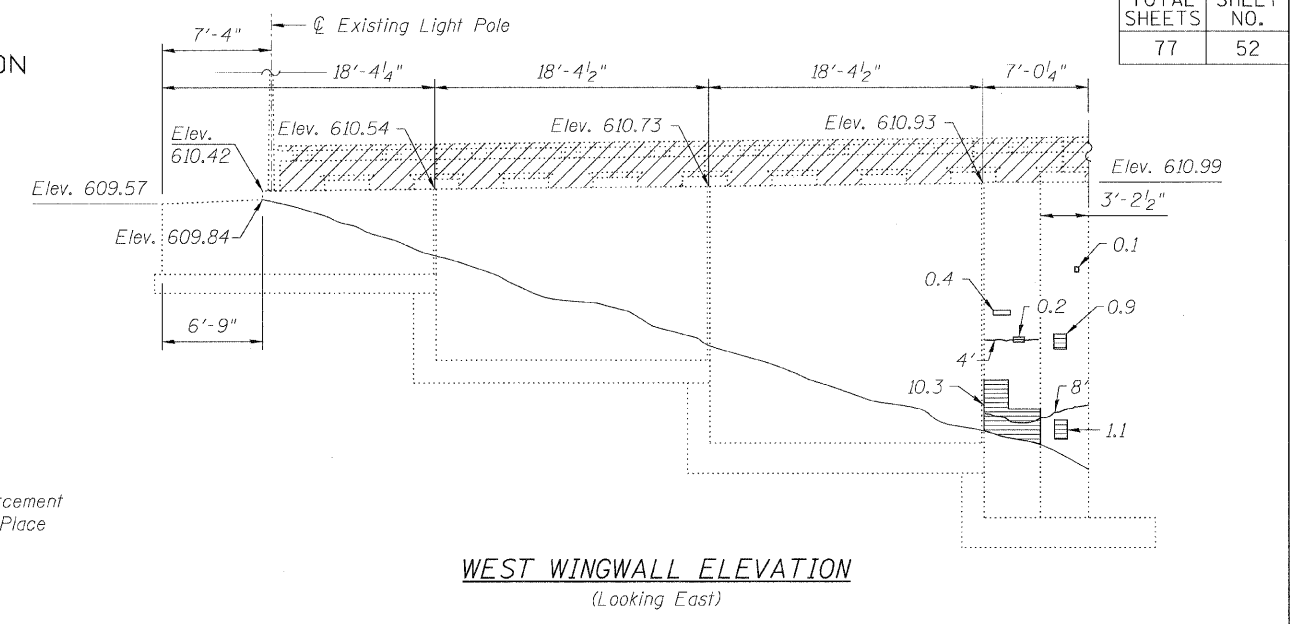
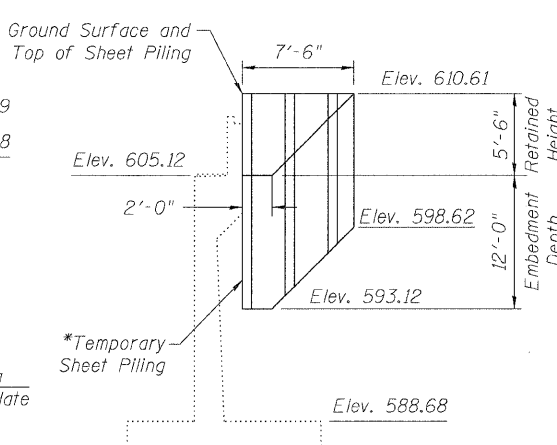
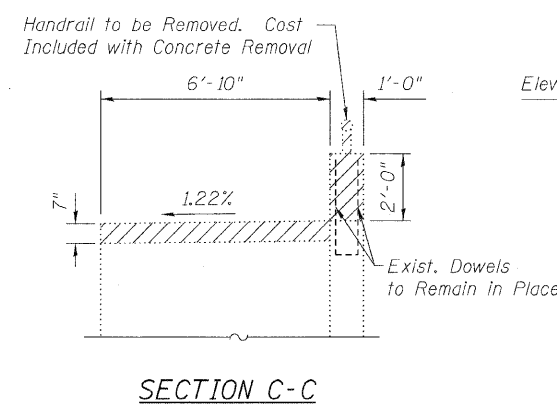
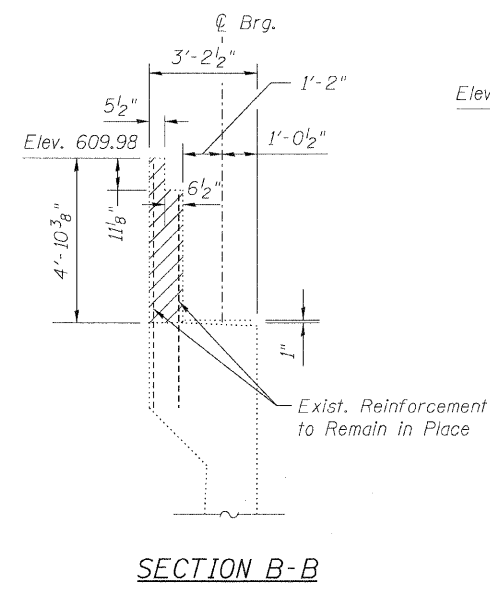
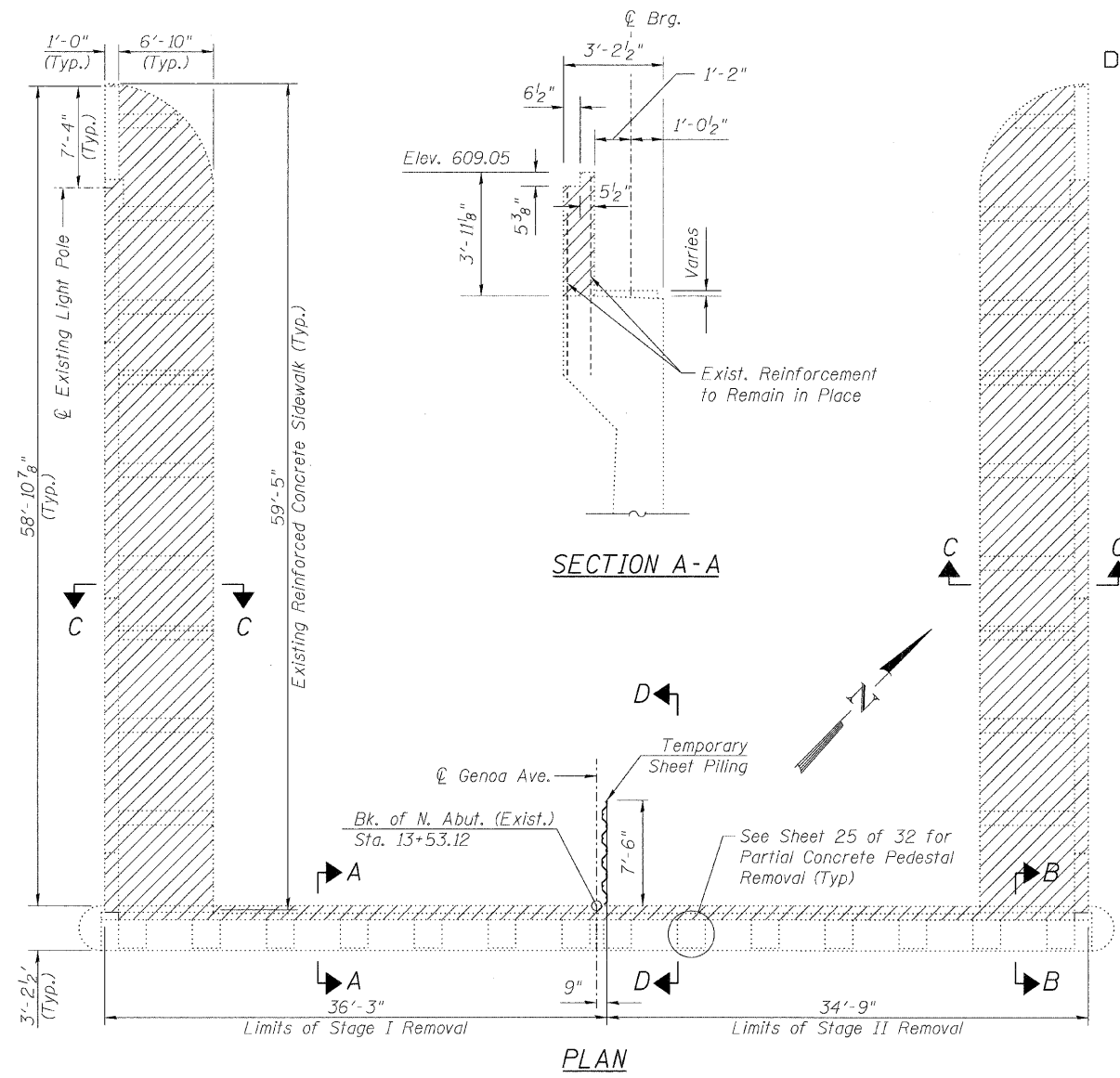

NOTES

- Existing vertical and horizontal reinforcement bars projecting from the abutment and wingwalls are to remain in place. Existing reinforcement shall be sandblasted clean, straightened and incorporated into the new construction. Cost included with Concrete Removal.
- Repair of the existing abutment shall include but not be limited to the areas shown. The actual areas to be repaired will be determined by the Engineer at the time of construction.
- If removal and remounting of the existing name plate is required to facilitate concrete repair, payment will not be made separately, but shall be included with the payment for Structural Repair of Concrete.

BILL OF MATERIAL

ITEM	UNIT	QUANTITY
Concrete Removal	Cu Yd	33.4
Temporary Sheet Piling	Sq Ft	117
Epoxy Crack Injection	Foot	59
Structural Repair of Concrete (Depth Equal to or Less than 5")	Sq Ft	240

LEGEND
 Indicates Limits of Concrete Removal
 Indicates Limits of Structural Repair of Concrete
 Indicates Length of Epoxy Crack Injection

ELEVATION
(Looking North)

* Minimum required section modulus is 4.65 in³/ft.

If the Contractor chooses to alter the temporary cantilevered sheet piling design requirements shown on the plans, a design submittal including plan details and calculations will be required for review and acceptance by the Engineer.

LIN ENGINEERING, LTD.
Consulting Engineers
Chattanooga, Illinois

Designed By: ESH
Checked By: MTH
Date: 7/2009

Drawn By: ESH
File: 016-2030.dgn

SHEET NO. 22
32 SHEETS

F.A.I. RTE.	SECTION	COUNTY	TOTAL SHEETS	SHEET NO.
57	2222.3B	COOK	77	52
FED. ROAD DIST. NO.			CONTRACT NO. 62119	
ILLINOIS			FED. AID PROJECT	

**NORTH ABUTMENT REMOVAL & REPAIRS
STRUCTURE NO. 016-2030**