

MILLED TEMPORARY RAMP  
(FOR BUTT JOINT AND HMA TAPER SEE DETAIL BELOW)

**OPTION 1**

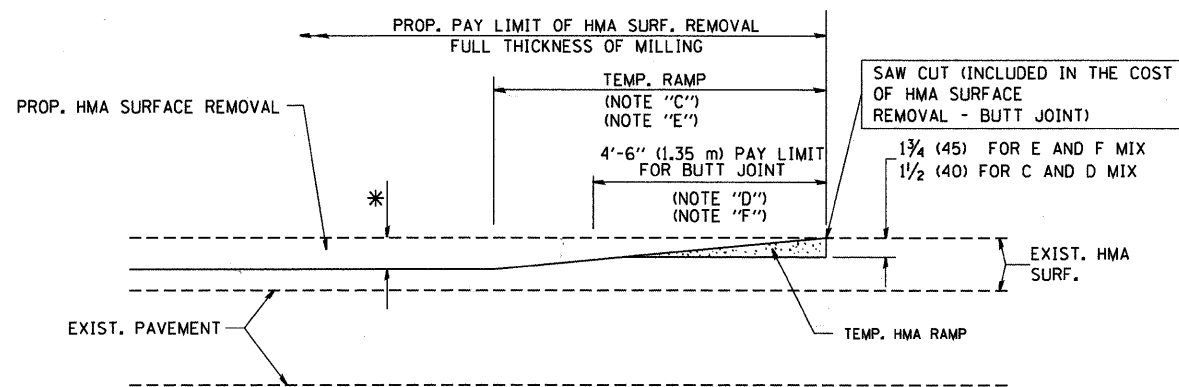

HMA CONSTRUCTED TEMPORARY RAMP  
(FOR BUTT JOINT AND HMA TAPER SEE DETAIL BELOW)

**OPTION 2**  
**TYPICAL TEMPORARY RAMP**

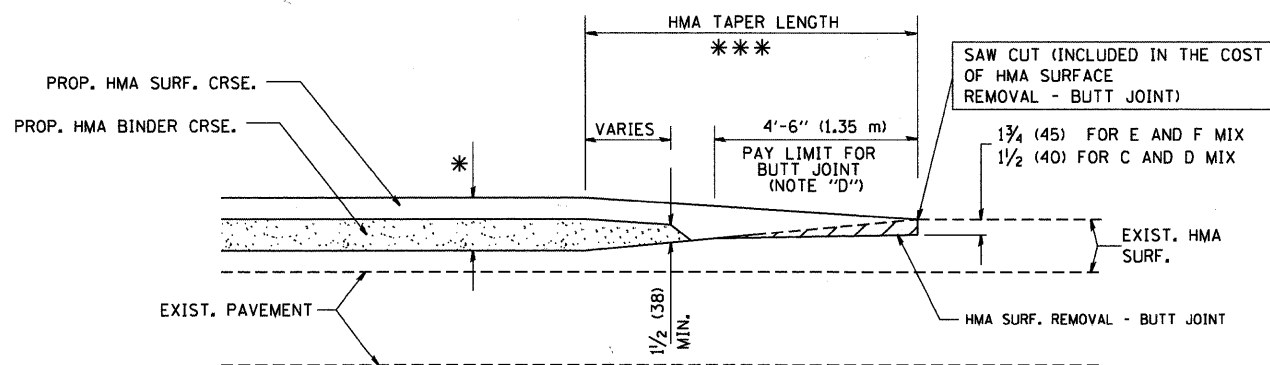

**TYPICAL BUTT JOINT AND HMA TAPER**  
**FOR MILLING AND RESURFACING**

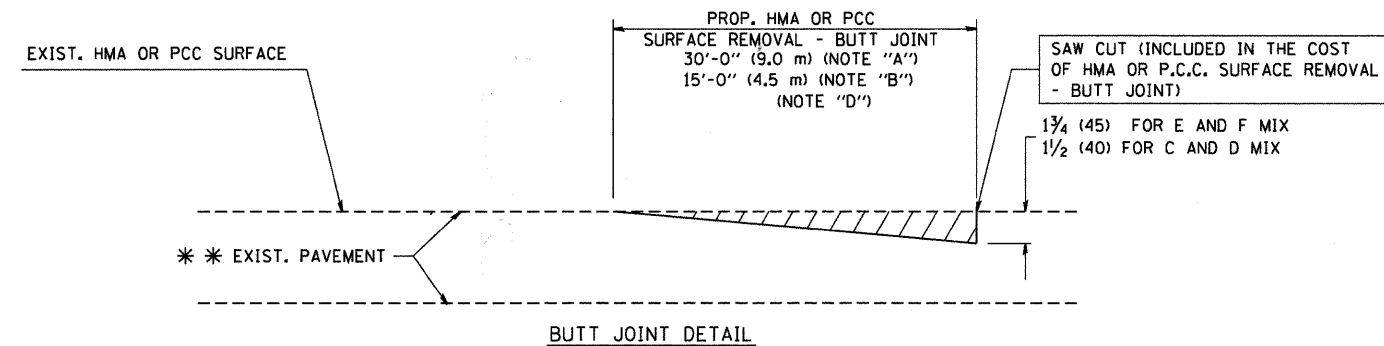

BUTT JOINT DETAIL

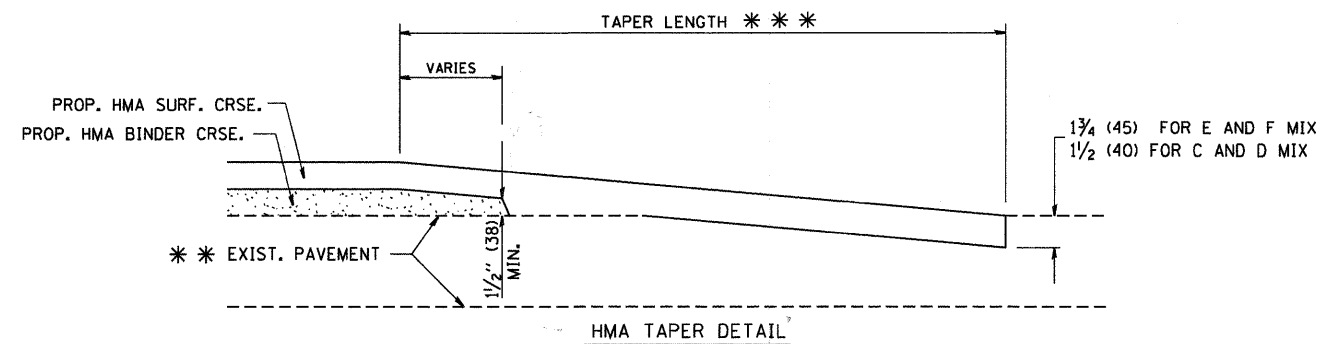

HMA TAPER DETAIL

**TYPICAL BUTT JOINT AND HMA TAPER**  
**FOR RESURFACING ONLY**

\*\*\* PC CONCRETE, HMA OR HMA RESURFACED PAVEMENT.

**NOTES**

- A: MAINLINE ROADWAYS AND MAJOR SIDE ROADS.
  - B: MINOR SIDE ROADS.
  - C: THE TEMP. RAMP SHALL BE CONSTRUCTED IMMEDIATELY UPON REMOVAL OF THE EXISTING HMA SURFACE.
  - D: THE BUTT JOINT SHALL BE CONSTRUCTED IMMEDIATELY PRIOR TO PLACING THE PROPOSED HMA COURSES.
  - E: TAPER THE TEMP. RAMP AT A RATE OF 3'-0" (900 mm) PER 1 INCH (25 mm) OF MILLING THICKNESS.
  - F: INSTALLATION AND REMOVAL OF THE 4'-6" (1.35 m) TEMP. RAMP IS INCLUDED IN COST OF HMA SURFACE REMOVAL - BUTT JOINT
  - G: SEE ARTICLE 406.08 AND 406.14 OF THE STANDARD SPECIFICATIONS FOR "HMA AND/OR PCC SURFACE REMOVAL, BUTT JOINT".
- \* SEE TYPICAL SECTIONS FOR MILLING THICKNESS.
- \*\*\* 20'-0" (6.1 m) PER 1 (25) RESURFACING (NOTE "A")  
10'-0" (3.0 m) PER 1 (25) RESURFACING (NOTE "B")

**BASIS OF PAYMENT:**

THE BUTT JOINT WILL BE PAID FOR AT THE CONTRACT UNIT PRICE PER SQUARE YARD (SQUARE METER) FOR "HOT-MIX ASPHALT SURFACE REMOVAL - BUTT JOINT" OR FOR "PORTLAND CEMENT CONCRETE SURFACE REMOVAL - BUTT JOINT".

ALL DIMENSIONS ARE IN INCHES (MILLIMETERS) UNLESS OTHERWISE SHOWN.

FILE NAME = W:\diststd\22x34\bd32.dgn	USER NAME = goglianob	DESIGNED - M. DE YONG	REVISED - R. SHAH 10-25-94
		DRAWN -	REVISED - A. ABBAS 03-21-97
	PLOT SCALE = 50.0000' / IN.	CHECKED -	REVISED - M. GOMEZ 04-06-01
	PLOT DATE = 1/4/2008	DATE - 06-13-90	REVISED - R. BORO 01-01-07

**STATE OF ILLINOIS**  
**DEPARTMENT OF TRANSPORTATION**

**BUTT JOINT AND**  
**HMA TAPER DETAILS**

SCALE: NONE SHEET NO. 1 OF 1 SHEETS STA. TO STA.

F.A. RTE.	SECTION	COUNTY	TOTAL SHEETS	SHEET NO.
0195	09-00057-00-RS	LAKE	23	18
BD400-05 BD32			CONTRACT NO. 63331	
FED. ROAD DIST. NO. 1 ILLINOIS FED. AID PROJECT ARA-9003 (450)				