

CONTRACT NO. 63365			
F.A. RTE.	SECTION	COUNTY	TOTAL SHEET NO.
359B	09-00020-00-RS	COOK	13 13
STA. 14+16.89		TO STA. 41+04.91	
FED. ROAD DIST. NO. 1 ILLINOIS FED. AID PROJECT			

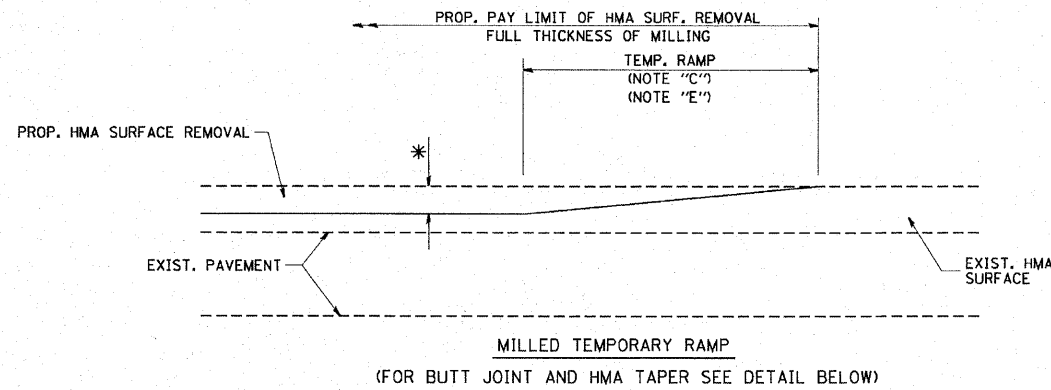

OPTION 1

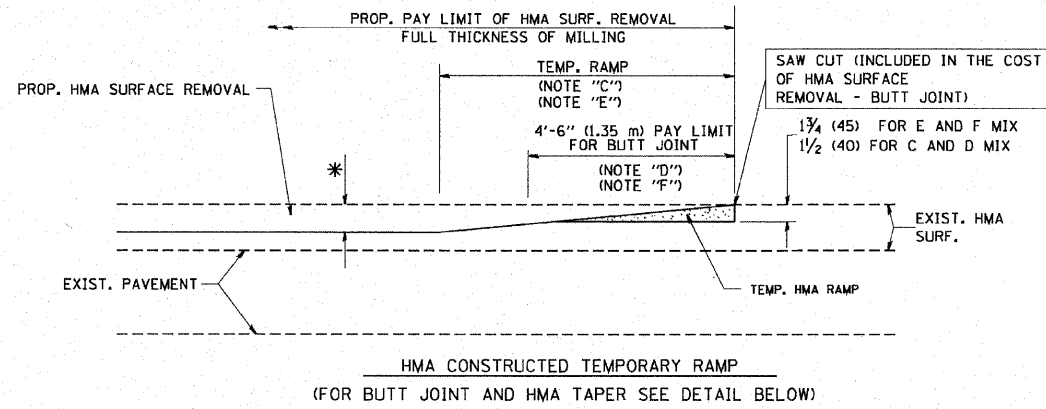

OPTION 2  
TYPICAL TEMPORARY RAMP

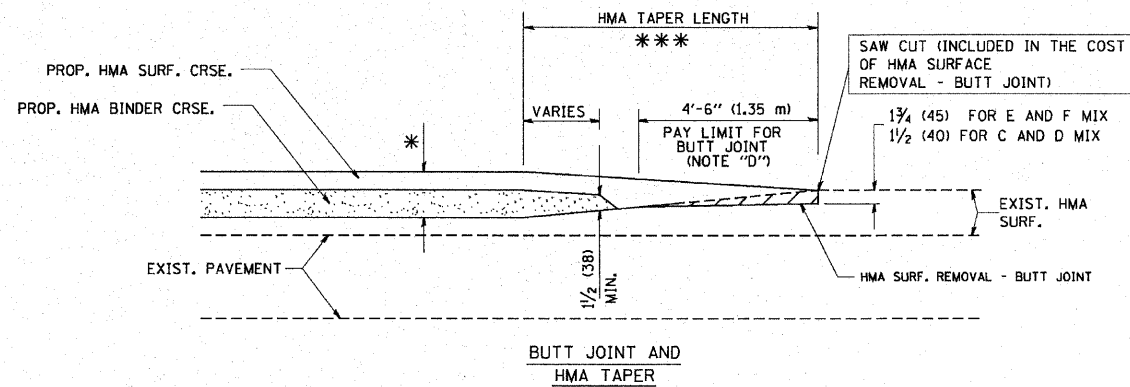

TYPICAL BUTT JOINT AND HMA TAPER  
FOR MILLING AND RESURFACING

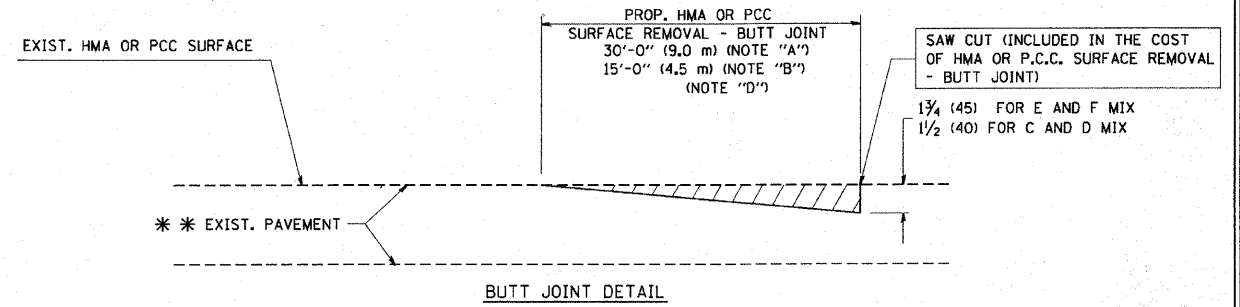

BUTT JOINT DETAIL

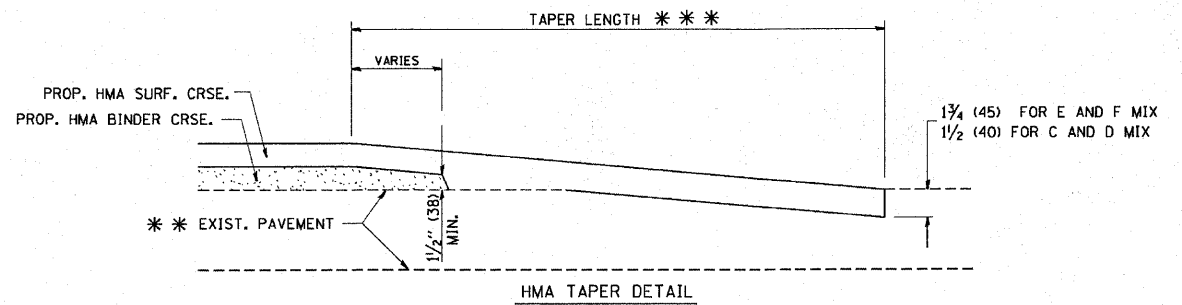

HMA TAPER DETAIL

TYPICAL BUTT JOINT AND HMA TAPER  
FOR RESURFACING ONLY

\*\*\* PC CONCRETE, HMA OR HMA RESURFACED PAVEMENT.

NOTES

- A: MAINLINE ROADWAYS AND MAJOR SIDE ROADS.
  - B: MINOR SIDE ROADS.
  - C: THE TEMP. RAMP SHALL BE CONSTRUCTED IMMEDIATELY UPON REMOVAL OF THE EXISTING HMA SURFACE.
  - D: THE BUTT JOINT SHALL BE CONSTRUCTED IMMEDIATELY PRIOR TO PLACING THE PROPOSED HMA COURSES.
  - E: TAPER THE TEMP. RAMP AT A RATE OF 3'-0" (900 mm) PER 1 INCH (25 mm) OF MILLING THICKNESS.
  - F: INSTALLATION AND REMOVAL OF THE 4'-6" (1.35 m) TEMP. RAMP IS INCLUDED IN COST OF HMA SURFACE REMOVAL - BUTT JOINT
  - G: SEE ARTICLE 406.08 AND 406.14 OF THE STANDARD SPECIFICATIONS FOR "HMA AND/OR PCC SURFACE REMOVAL, BUTT JOINT".
- \* SEE TYPICAL SECTIONS FOR MILLING THICKNESS.
- \*\*\* 20'-0" (6.1 m) PER 1 (25) RESURFACING (NOTE "A")  
10'-0" (3.0 m) PER 1 (25) RESURFACING (NOTE "B")

ALL DIMENSIONS ARE IN INCHES (MILLIMETERS) UNLESS OTHERWISE SHOWN.

REVISIONS	
NAME	DATE
M. DE YONG	6-13-90
M. DE YONG	7-3-90
M. DE YONG	3-27-92
R. SHAH	09/09/94
R. SHAH	10/23/94
A. ABBAS	03/21/97
M. GOMEZ	04/06/01
R. BORO	01/01/07

ILLINOIS DEPARTMENT OF TRANSPORTATION

BUTT JOINT AND  
HMA TAPER  
DETAILS

BASIS OF PAYMENT:

THE BUTT JOINT WILL BE PAID FOR AT THE CONTRACT UNIT PRICE PER SQUARE YARD (SQUARE METER) FOR "HOT-MIX ASPHALT SURFACE REMOVAL - BUTT JOINT" OR FOR "PORTLAND CEMENT CONCRETE SURFACE REMOVAL - BUTT JOINT".

SCALE: VERT. NONE  
HORIZ.

DRAWN BY  
CHECKED BY  
BD400-05 (VI-BD32)

AKHRAS ASSOCIATES, INC.  
 A DESIGN FIRM REGISTERED IN THE STATE OF ILLINOIS  
 LICENSE NO. 184-000630  
 9306 S. DIELL AVENUE • BRIDGEVIEW, IL 60455  
 TEL. (708) 599-1101 • FAX. (708) 599-2238

PLOT DATE = 3/16/2007  
 FILE NAME = K:\G10103\0302299  
 PLOT SCALE = 0.80000 / 1 IN.  
 USER NAME = bward

TEL: (708) 599-2238