

F.A.P. RTE.	SECTION	COUNTY	TOTAL SHEETS	SHEET NO.
332	47RS-5	VERMILION	41	1
		ILLINOIS	CONTRACT NO. 70784	

STATE OF ILLINOIS
DEPARTMENT OF TRANSPORTATION
DIVISION OF HIGHWAYS

PROPOSED HIGHWAY PLANS

F.A.P. ROUTE 332 (IL 1/u.S.150)
SECTION 47RS-5
PROJECT ACNHF-0332 (099)
RESURFACING (3P) COLD MILLING
VERMILION COUNTY

C-95-052-09

MAIN STREET IN DANVILLE TO 16TH STREET IN TILTON

FOR INDEX OF SHEETS, SEE SHEET NO. 2
FOR SUMMARY OF QUANTITIES SEE SHEET NO. 4-7

CURRENT ADT: (2010)	
LEG "A"	= 26,300
LEG "B"	= 23,200
LEG "C"	= 26,900
LEG "D"	= 24,800

PAVING OMISSIONS

S. N. 092-0039 = STA. 3041+70 TO 3043+70
S. N. 092-0038 = STA. 3052+85 TO 3056+36
CONCRETE SECTION = STA. 3061+50 TO 3080+85

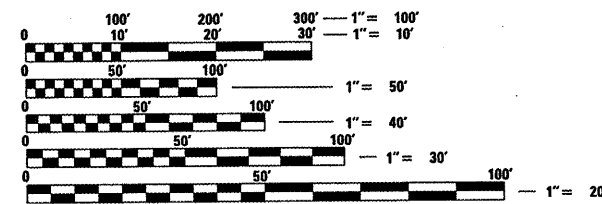
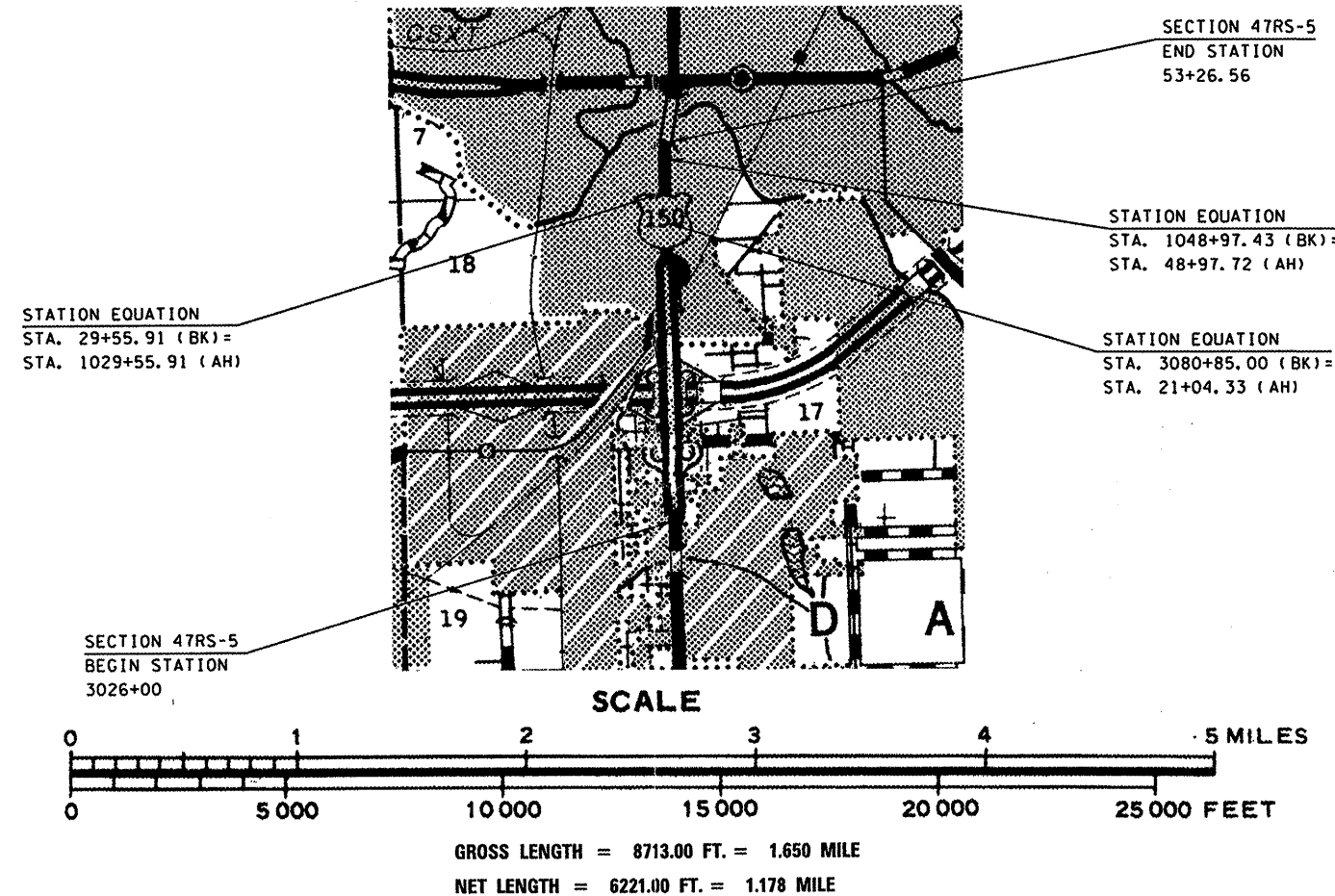
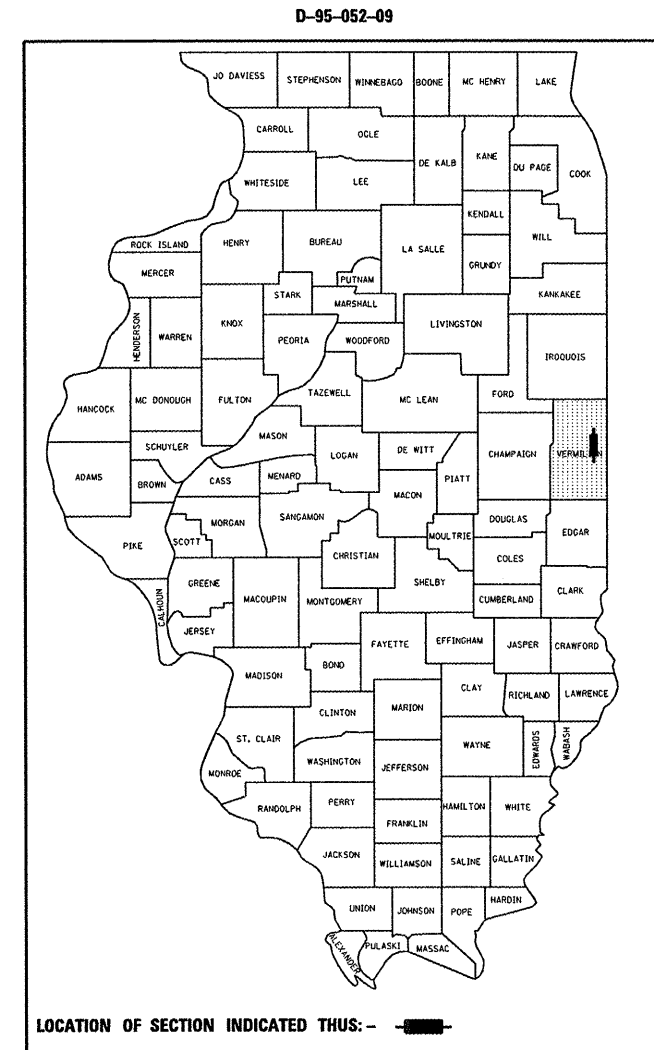

FULL SIZE PLANS HAVE BEEN PREPARED USING STANDARD ENGINEERING SCALES. REDUCED SIZED PLANS WILL NOT CONFORM TO STANDARD SCALES. IN MAKING MEASUREMENTS ON REDUCED PLANS, THE ABOVE SCALES MAY BE USED.

J.U.L.I.E.
JOINT UTILITY LOCATION INFORMATION FOR EXCAVATION
1-800-892-0123
OR 811

PROJECT ENGINEER: NANCY FASIG
PROJECT MANAGER: MARK S. BLAKENEY
(217)-465-4181
CONTRACT NO. 70784

STATE OF ILLINOIS
DEPARTMENT OF TRANSPORTATION
DIVISION OF HIGHWAYS

SUBMITTED 3/15 2010
Scott E. Corbett
DEPUTY DIRECTOR OF HIGHWAYS, REGION ENGINEER

May 7 2010
Scott E. Still P.E. IBI
ACTING ENGINEER OF DESIGN AND ENVIRONMENT

May 7 2010
Christine M. Reed IBI
DIRECTOR OF HIGHWAYS, CHIEF ENGINEER

PRINTED BY THE AUTHORITY
OF THE STATE OF ILLINOIS

INDEX OF SHEETS

SHEET	ITEM
1	COVER SHEET
2	INDEX OF SHEETS
2	HIGHWAY STANDARDS
3-4	GENERAL NOTES
4-6	SUMMARY OF QUANTITIES
7-11	EXISTING-PROPOSED TYPICALS
12-20	SCHEDULE OF QUANTITIES
21-32	PLAN SHEETS
33	DETAIL-SIDEROAD RETURNS
34	DETAIL-TRAFFIC CONTROL FOR RAMP CLOSURES-APPLICATION #2
35	DETAIL-SIDESTREET/STREET CLOSURES
36-39	DETAIL-PAVEMENT MARKING & MARKERS (RURAL & URBAN APPLICATIONS)
40	DETAIL- SURVEY MARKERS TY 1 & 2 (SPECIAL)
41	DETAIL-SURVEY MONUMENT COVER ASSEMBLY

LIST OF HIGHWAY STANDARDS

000001-05	STANDARD SYMBOLS, ABBREVIATIONS, AND PATTERNS
442201-03	CLASS C AND D PATCHES
667101-01	PERMANENT SURVEY MARKERS
701411-06	LANE CLOSURE, MULTI-LANE , AT ENTRANCE OR EXIT RAMP 45 MPH
701426-03	LANE CLOSURE, MULTI-LANE - INTERMITTENT OR MOVING OPERATION, 45 MPH
701602-04	URBAN LANE CLOSURE, MULTILANE, 2 W WITH BIDIRECTIONAL LEFT TURN LANE
701606-06	URBAN LANE CLOSURE, MULTILANE, 2 W WITH MOUNTABLE MEDIAN
701701-06	URBAN LANE CLOSURE, MULTILANE INTERSECTION
701901-01	TRAFFIC CONTROL DEVICES
780001-02	TYPICAL PAVEMENT MARKINGS
781001-03	TYPICAL APPLICATIONS RAISED REFLECTIVE PAVEMENT MARKERS

FILE NAME =	USER NAME = bucklesjj	DESIGNED -	REVISED -	STATE OF ILLINOIS DEPARTMENT OF TRANSPORTATION	INDEX OF SHEETS/HIGHWAY STANDARDS	F.A.P. RTE.	SECTION	COUNTY	TOTAL SHEETS	SHEET NO.
es:\pwork\PKWIDOT\BUCKLESJJ\0184908\0370784-sht-Gernote.dgn		DRAWN -	REVISED -			332	47RS-5	VERMILION	41	2
PLOT SCALE = 40,0000 1/ IN.		CHECKED -	REVISED -			CONTRACT NO. 70784				
PLOT DATE = 3/15/2010		DATE -	REVISED -			SCALE: N/A	SHEET NO. OF SHEETS	STA. TO STA.	FED. ROAD DIST. NO.	ILLINOIS FED. AID PROJECT

GENERAL NOTES

G.N.-100

ENGLISH UNITS OF MEASUREMENT SHALL GOVERN OVER AND SUPERSEDE ANY METRIC UNITS SHOWN IN THIS CONTRACT. WHERE INCLUDED, METRIC UNITS ARE FOR INFORMATION ONLY.

G.N.-105.09A

ALL ELEVATIONS SHOWN IN THE PLANS ARE BASED ON NORTH AMERICAN VERTICAL DATUM OF 1988. (NAVD 88)

G.N.-406

THE QUANTITIES INCLUDED IN THE PLANS FOR HOT-MIX ASPHALT RESURFACING ARE INTENDED TO GIVE THE COVERAGE SHOWN ON THE TYPICAL CROSS SECTIONS. IT IS NOT INTENDED TO INCREASE THE THICKNESS OF THE HOT-MIX ASPHALT MIXTURE IN ORDER TO USE ALL OF THE QUANTITIES INCLUDED IN THE CONTRACT.

G.N.-406.05b

ALL LEVELING BINDER OR BINDER SHALL BE GIVEN A FOG COAT OF PRIME BEFORE THE SURFACE COURSE IS PLACED WHEN DIRECTED BY THE ENGINEER. THE FOG COAT WILL BE PAID FOR AT THE CONTRACT UNIT PRICE PER GALLON FOR BITUMINOUS MATERIAL (PRIME COAT) AND NO ADDITIONAL COMPENSATION WILL BE ALLOWED.

G.N.-406.10

FOR MULTILANE RESURFACING

WHEN BEGINNING THE RESURFACING WITH NEW MIXTURES FOR LEVELING BINDER, BINDER COURSE, AND SURFACE COURSE MIXTURES, THE WORK WILL BE CONFINED TO THE INSIDE TRAFFIC LANE (PASSING LANE) FIRST. THE WORK WILL REMAIN ON THE INSIDE LANE UNTIL THE MIX HAS BEEN ADJUSTED AND APPROVED BY THE ENGINEER BEFORE ANY RESURFACING IS ALLOWED ON THE OUTSIDE (DRIVING) TRAFFIC LANE(S).

ANY DELAYS OR INCONVENIENCES CAUSED THE CONTRACTOR IN COMPLYING WITH THIS REQUIREMENT WILL BE CONSIDERED INCIDENTAL TO THE VARIOUS HOT-MIX ASPHALT PAY ITEMS, AS SHOWN IN THE CONTRACT, AND NO ADDITIONAL COMPENSATION WILL BE ALLOWED.

GN 406H MIXTURE REQUIREMENTS

The following mixture requirements are applicable for this project:

Location	IL 1/US 150	IL 1/US 150	IL 1/US 150	IL 1/US 150
Mixture Use	POLYMER SURFACE	POLYMER LEVEL BIND	CLASS D PATCHING	INCIDENTAL HMA SURF
AC/PG	SBS PG 70-22	SBS PG 70-22	PG 64-22	PG 64-22
RAP % (Max)	10	10	10	15
Design Air Voids	4.0% @ Ndes=90	4.0% @ Ndes=90	4.0% @ Ndes=90	4.0% @ Ndes=90
Mix Comp(Gradation)	IL 9.5	IL 9.5	IL 19.0	IL 9.5
Friction Aggregate	MIX E	MIX C	N/A	MIX C

G.N.-408B

THE INCIDENTAL HOT-MIX ASPHALT SURFACING SHALL BE COMPACTED AS REQUIRED BY THE SPECIFICATIONS FOR DESIGN NUMBER OF GYRATIONS BEING USED, AT THE FOLLOWING LOCATIONS:

3RD STREET

G.N.-442B – PATCHING SCHEDULES

THE PATCHING SCHEDULES INCLUDED IN THE PLANS REPRESENT THE BEST INFORMATION AVAILABLE AT THE TIME OF COMPLETION OF THE PLANS FOR LETTING. VARIATIONS IN LOCATION AND SIZES OF BOTH FULL-DEPTH AND PARTIAL-DEPTH PATCHES MAY OCCUR.

G.N.-667

THE RESIDENT ENGINEER SHALL CONTACT THE PROGRAM DEVELOPMENT CHIEF OF SURVEYS PRIOR TO THE PRE-CONSTRUCTION CONFERENCE FOR INSTRUCTION AS TO SETTING OF TEMPORARY OR PERMANENT TIES FOR CENTERLINE ALIGNMENT CONTROL SURVEY MARKERS (PC'S, PT'S, AND PI'S). PROJECT IMPLEMENTATION PERSONNEL WILL BE RESPONSIBLE FOR SETTING THESE MARKERS.

G.N.-703A

SHORT TERM PAVEMENT MARKING SHALL BE APPLIED TO THE PAVEMENT AFTER ANY OF THE FOLLOWING: COLD MILLING AND/OR PLACING BITUMINOUS MATERIALS (PRIME COAT), LEVELING BINDER (MACHINE METHOD), BINDER AND SURFACE COURSES. SHORT TERM PAVEMENT MARKING PLACED ON THE SURFACE, SHALL COINCIDE WITH THE FINAL PAVEMENT STRIPING. SHORT TERM PAVEMENT MARKING PLACED PRIOR TO THE SURFACE SHALL COINCIDE WITH THE EXISTING PAVEMENT MARKINGS. USE 4 FEET PER 40 FEET (OR 10% PER STATION).

G.N.-781

RAISED REFLECTIVE PAVEMENT MARKERS SHALL BE PLACED IN ACCORDANCE WITH STANDARD 781001, AND THE DETAILS SHOWN IN THE PLANS. IF THERE IS ANY DISCREPANCY BETWEEN THE STANDARD AND THE DETAILS IN THE PLANS, THE DETAILS IN THE PLANS SHALL GOVERN. THE FINAL PAVEMENT MARKINGS SHALL BE IN PLACE PRIOR TO PLACING THE RAISED REFLECTIVE PAVEMENT MARKERS AND THE RAISED REFLECTIVE PAVEMENT MARKERS SHALL BE PLACED MIDWAY IN THE 30 FOOT (9 m) SPACE BETWEEN THE DASHED CENTERLINE STRIPES (WHEN APPLICABLE).

NO COMMITMENTS

FILE NAME =	USER NAME = bucklesjj	DESIGNED -	REVISED -	STATE OF ILLINOIS DEPARTMENT OF TRANSPORTATION	GENERAL NOTES	F.A.P. RTE.	SECTION	COUNTY	TOTAL SHEETS	SHEET NO.
ca:\pwork\PM100T\BUCKLESJJ\0184908\0570784-shr-Gennote.dgn	DRAWN -	REVISED -	332			47RS-5	VERMILION	41	3	
PLOT SCALE = 40.0000 ' / IN.	CHECKED -	REVISED -	CONTRACT NO. 70784							
PLOT DATE = 3/15/2010	DATE -	REVISED -	SCALE: N/A			SHEET NO. OF SHEETS	STA. TO STA.	FED. ROAD DIST. NO.	ILLINOIS FED. AID PROJECT	

SUMMARY OF QUANTITIES

LOCATION OF WORK:

FAP 332 (IL 1& US 150)
 VERMILION COUNTY
 URBAN
 STA. 3026+00
 TO
 STA 53+26.56
 80% FED
 20% STATE
 I000

CONSTRUCTION TYPE CODE:

CODE NO	ITEM	UNIT	TOTAL QUANTITY
40600100	BITUMINOUS MATERIALS(PRIME COAT)	GALLON	4447.0
40600300	AGGREGATE (PRIME COAT)	TON	89.0
40600845	POLYMERIZED LEVELING BINDER (MACHINE METHOD), N90	TON	1868.0
40600895	CONSTRUCTING TEST STRIP	EACH	1.0
40600982	HOT-MIX ASPHALT SURFACE REMOVAL, BUTT JOINT	SQ YD	2085.0
40600990	TEMPORARY RAMPS	SQ YD	1446.0
40603570	POLYMERIZED HOT-MIX ASPHALT, SURFACE COURSE, MIX"E",N90	TON	3735.0
40800010	BITUMINOUS MATERIALS(PRIME COAT)	GALLON	209.0
40800030	AGGREGATE (PRIME COAT)	TON	5.0
40800050	INCIDENTAL HOT-MIX ASPHALT SURFACING	TON	175.0
44000158	HOT-MIX ASPHALT SURFACE REMOVAL, 2 1/4"	SQ YD	44465.0
44201815	CLASS D PATCHES, TY II, 14 INCH	SQ YD	168.0
44201819	CLASS D PATCHES, TY III, 14 INCH	SQ YD	64.0
44201847	CLASS D PATCHES, TY I, 17 INCH	SQ YD	25.0
44201851	CLASS D PATCHES, TY II, 17 INCH	SQ YD	174.0
44201855	CLASS D PATCHES, TY III, 17 INCH	SQ YD	40.0
44201857	CLASS D PATCHES, TY IV, 17 INCH	SQ YD	37.0

FILE NAME = c:\pwork\pwork\BUCKLESJJ\d0184908\0	USER NAME = bucklesjj 78784-shr-500.dgn	DESIGNED -	REVISED -	STATE OF ILLINOIS DEPARTMENT OF TRANSPORTATION	SUMMARY OF QUANTITIES	F.A.P. RTE. 332	SECTION 47RS-5	COUNTY Vermilion	TOTAL SHEETS 41	SHEET NO. 4
	PLOT SCALE = 48.0000' / IN.	CHECKED -	REVISED -							
	PLOT DATE = 3/15/2010	DATE -	REVISED -		SCALE:	SHEET NO.	OF	SHEETS	STA.	TO STA.
ILLINOIS FED. AID PROJECT CONTRACT NO. 70784										

SUMMARY OF QUANTITIES

LOCATION OF WORK:

FAP 332 (IL 1 & US 150)
 VERMILION COUNTY
 URBAN
 STA. 3026+00
 TO
 STA 53+26.56
 80% FED
 20% STATE
 1000

CONSTRUCTION TYPE CODE:

CODE NO	ITEM	UNIT	TOTAL QUANTITY
44300200	STRIP REFLECTIVE CRACK CONTROL TREATMENT	FOOT	10661.0
60300305	FRAMES AND LIDS TO BE ADJUSTED	EACH	18.0
60300405	VALVE BOX FRAMES TO BE ADJUSTED	EACH	13.0
67000500	ENGINEERS FIELD OFFICE, TYPE B	CAL MO	3.0
67100100	MOBILIZATION	EACH	1.0
X7015005	CHANGEABLE MESSAGE SIGN	CAL DAY	8.0
70100420	TRAFFIC CONTROL AND PROTECTION, STANDARD 701411	EACH	10.0
70102625	TRAFFIC CONTROL AND PROTECTION, STANDARD 701606	LUMP SUM	1.0
70102632	TRAFFIC CONTROL AND PROTECTION, STANDARD 701602	LUMP SUM	1.0
70102635	TRAFFIC CONTROL AND PROTECTION, STANDARD 701701	LUMP SUM	1.0
70300100	SHORT-TERM PAVEMENT MARKING	FOOT	3864.0
70300210	TEMPORARY PAVEMENT MARKING, LETTERS AND SYMBOLS	SQ FT	640.0
70300220	TEMPORARY PAVEMENT MARKING, LINE 4 INCH	FOOT	22355.0
70300240	TEMPORARY PAVEMENT MARKING, LINE 6 INCH	FOOT	286.0
70300250	TEMPORARY PAVEMENT MARKING, LINE 8 INCH	FOOT	2728.0
70300260	TEMPORARY PAVEMENT MARKING, LINE 12 INCH	FOOT	502.0
70300280	TEMPORARY PAVEMENT MARKING, LINE 24 INCH	FOOT	85.0

FILE NAME =	USER NAME = buckleejj	DESIGNED -	REVISED -	STATE OF ILLINOIS DEPARTMENT OF TRANSPORTATION	SUMMARY OF QUANTITIES				F.A.P. RTE.	SECTION	COUNTY	TOTAL SHEETS	SHEET NO.
ct:\pw\work\PWIDOT\BUCKLESJJ\d0184908\05	70784-shr-500.dgn	DRAWN -	REVISED -		332	47RS-5	Vermilion	41	5				
	PLOT SCALE = 48.0000 / IN.	CHECKED -	REVISED -						CONTRACT NO. 70784				
	PLOT DATE = 3/15/2010	DATE -	REVISED -		SCALE:	SHEET NO.	OF	SHEETS	STA.	TO STA.	ILLINOIS FED. AID PROJECT		

SUMMARY OF QUANTITIES

LOCATION OF WORK:

FAP 332 (IL 1 & US 150)
 VERMILION COUNTY
 URBAN
 STA. 3026+00
 TO
 STA 53+26.56
 80% FED
 20% STATE

CONSTRUCTION TYPE CODE:

1000

CODE NO	ITEM	UNIT	TOTAL QUANTITY
70301000	WORK ZONE PAVEMENT MARKING REMOVAL	SQ FT	9990.0
* 78000100	THERMOPLASTIC PAVEMENT MARKING, LETTERS AND SYMBOLS	SQ FT	640.0
* 78000200	THERMOPLASTIC PAVEMENT MARKING, LINE 4 INCH	FOOT	22355.0
* 78000400	THERMOPLASTIC PAVEMENT MARKING, LINE 6 INCH	FOOT	286.0
* 78000500	THERMOPLASTIC PAVEMENT MARKING, LINE 8 INCH	FOOT	2728.0
* 78000600	THERMOPLASTIC PAVEMENT MARKING, LINE 12 INCH	FOOT	502.0
* 78000650	THERMOPLASTIC PAVEMENT MARKING, LINE 24 INCH	FOOT	85.0
* 78100100	RAISED REFLECTIVE PAVEMENT MARKER	EACH	431.0
78300200	RAISED REFLECTIVE PAVEMENT MARKER REMOVAL	EACH	431.0
XZ193400	SURVEY MARKERS, TYPE 2 (SPECIAL)	EACH	4.0
Z0070100	SURVEY MONUMENT COVER ASSEMBLY	EACH	5.0

* SPECIALTY ITEM

FILE NAME =	USER NAME = bucklesjj	DESIGNED -	REVISED -	STATE OF ILLINOIS DEPARTMENT OF TRANSPORTATION	SUMMARY OF QUANTITIES			F.A.P. RTE.	SECTION	COUNTY	TOTAL SHEETS	SHEET NO.
ct:\pwork\PMIDOT\BUCKLESJJ\0184908\0570784-sht-500.dgn		DRAWN -	REVISED -		332	47RS-5	Vermilion	41	6			
PLOT SCALE = 48,0000 ' / IN.		CHECKED -	REVISED -		CONTRACT NO. 70784			ILLINOIS FED. AID PROJECT				
PLOT DATE = 3/15/2010		DATE -	REVISED -		SCALE:	SHEET NO.	OF SHEETS	STA.	TO STA.			

EXISTING TYPICAL SECTION

STA. 3026+00 TO STA. 3029+60

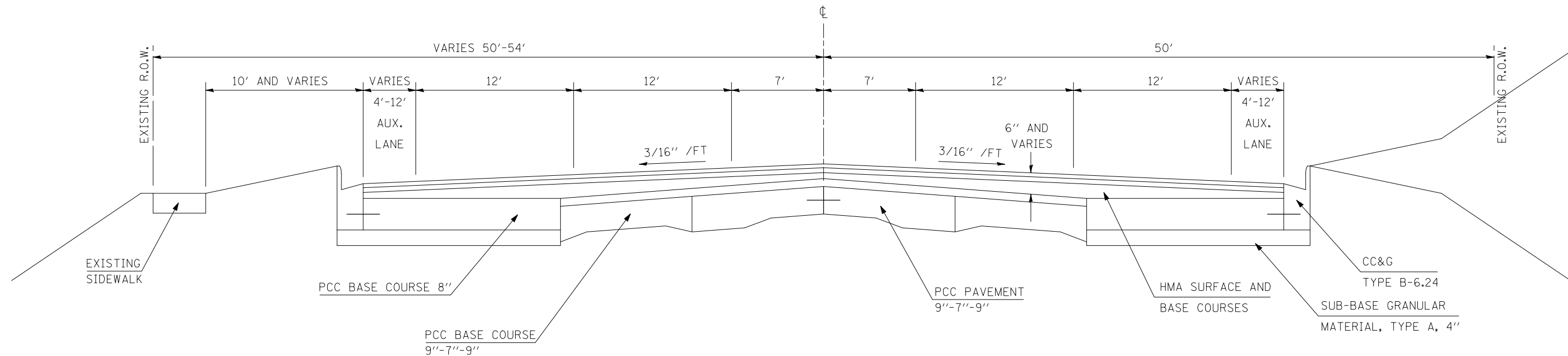

PROPOSED TYPICAL SECTION

STA. 3026+00 TO STA. 3029+60

- 1 STA. 3026+00 TO STA. 3027+82
4' AUXILLARY LANE
- 2 STA. 3028+38 TO STA. 3029+00
12' AUXILLARY LANE
- 3 STA. 3026+00 TO STA. 3028+95
4' AUXILLARY LANE
- 4 STA. 3029+51 TO STA. 3029+60
12' AUXILLARY LANE

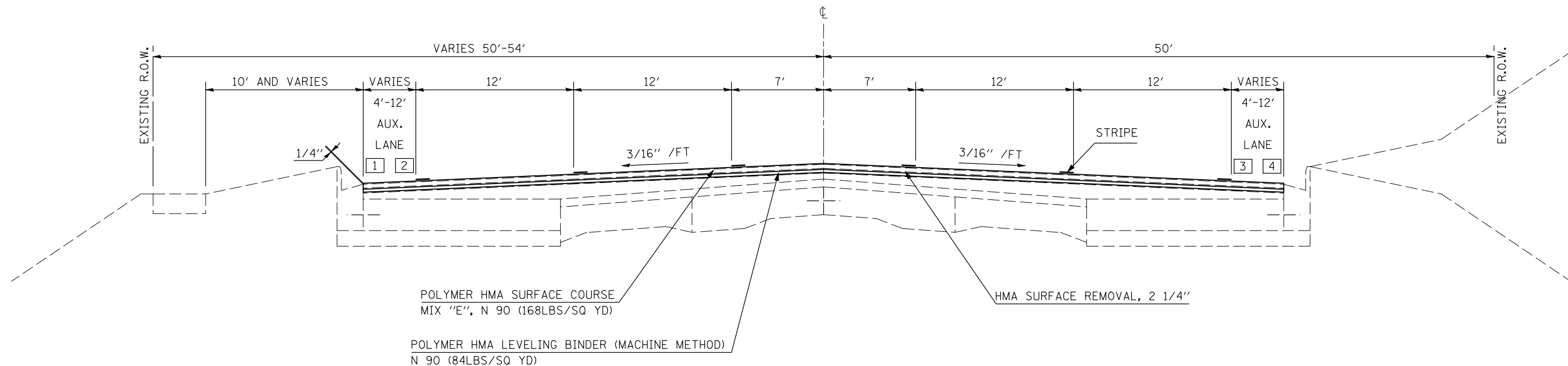

FILE NAME =	USER NAME = bucklesjj	DESIGNED -	REVISED -
ct:\pw\work\PIWIDOT\BUCKLESJJ\d0184908\070784-sht-typical.dgn		DRAWN -	REVISED -
PLOT SCALE = 40.0000' / IN.		CHECKED -	REVISED -
PLOT DATE = 3/15/2010		DATE -	REVISED -

STATE OF ILLINOIS
DEPARTMENT OF TRANSPORTATION

TYPICAL SECTIONS

SCALE: SHEET NO. OF SHEETS STA. TO STA.

F.A.P. RTE.	SECTION	COUNTY	TOTAL SHEETS	SHEET NO.
332	47RS-5	VERMILION	41	7
CONTRACT NO. 70784				
ILLINOIS FED. AID PROJECT				

EXISTING TYPICAL SECTION

STA. 3029+60 TO STA. 3061+50

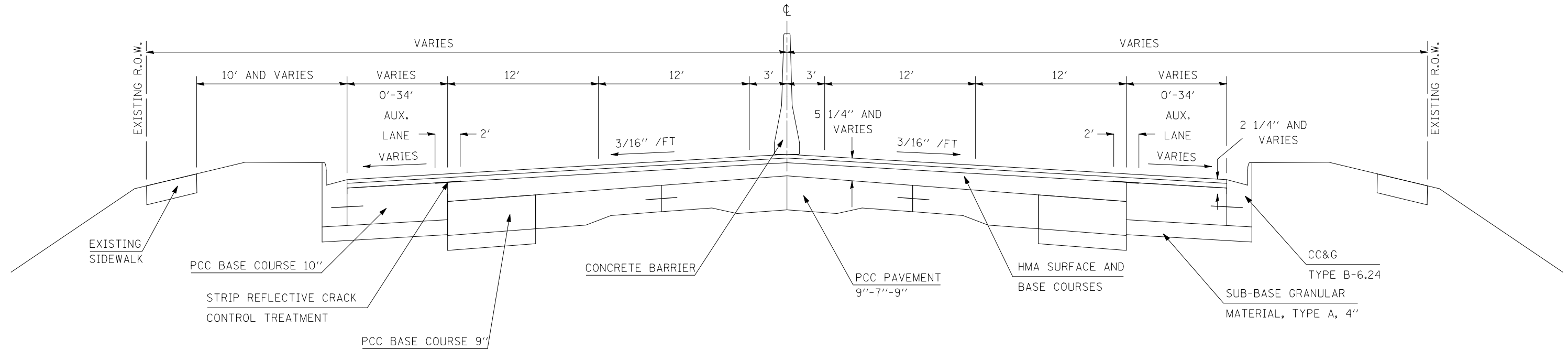

PROPOSED TYPICAL SECTION

STA. 3029+60 TO STA. 3061+50

- 5 STA. 3029+60 TO STA. 3031+65
12' AUXILLARY LANE
- 6 STA. 3036+81 TO STA. 3039+14
STA. 3046+70 TO STA. 3048+72
STA. 3057+54 TO STA. 3059+36
0' AUXILLARY LANE

- 7 STA. 3040+81 TO STA. 3041+70
STA. 3051+80 TO STA. 3052+85
STA. 3056+36 TO STA. 3056+97
6' AUXILLARY LANE
- 8 STA. 3029+60 TO STA. 3030+12
12' AUXILLARY LANE

- 9 STA. 3030+75 TO STA. 3033+57
STA. 3034+74 TO STA. 3038+84
STA. 3048+82 TO STA. 3051+70
0' AUXILLARY LANE
- 10 STA. 3043+71 TO STA. 3044+65
STA. 3056+36 TO STA. 3057+18
16' AUXILLARY LANE

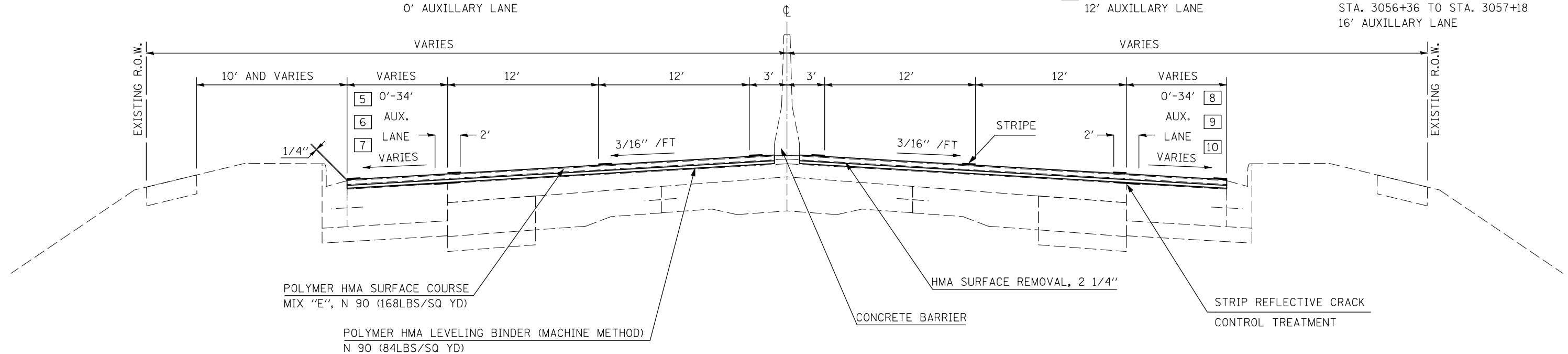

FILE NAME =	USER NAME = bucklesjj	DESIGNED -	REVISED -
ct:\pw\work\PWIDOT\BUCKLESJJ\d0184908\070784-sht-typicals.dgn		DRAWN -	REVISED -
PLOT SCALE = 40.0000' / IN.		CHECKED -	REVISED -
PLOT DATE = 3/15/2010		DATE -	REVISED -

STATE OF ILLINOIS
DEPARTMENT OF TRANSPORTATION

TYPICAL SECTIONS

SCALE: SHEET NO. OF SHEETS STA. TO STA.

F.A.P. RTE.	SECTION	COUNTY	TOTAL SHEETS	SHEET NO.
332	47RS-5	VERMILION	41	8
CONTRACT NO. 70784				
ILLINOIS FED. AID PROJECT				

EXISTING TYPICAL SECTION

STA. 21 + 04.30 TO STA. 27 + 60

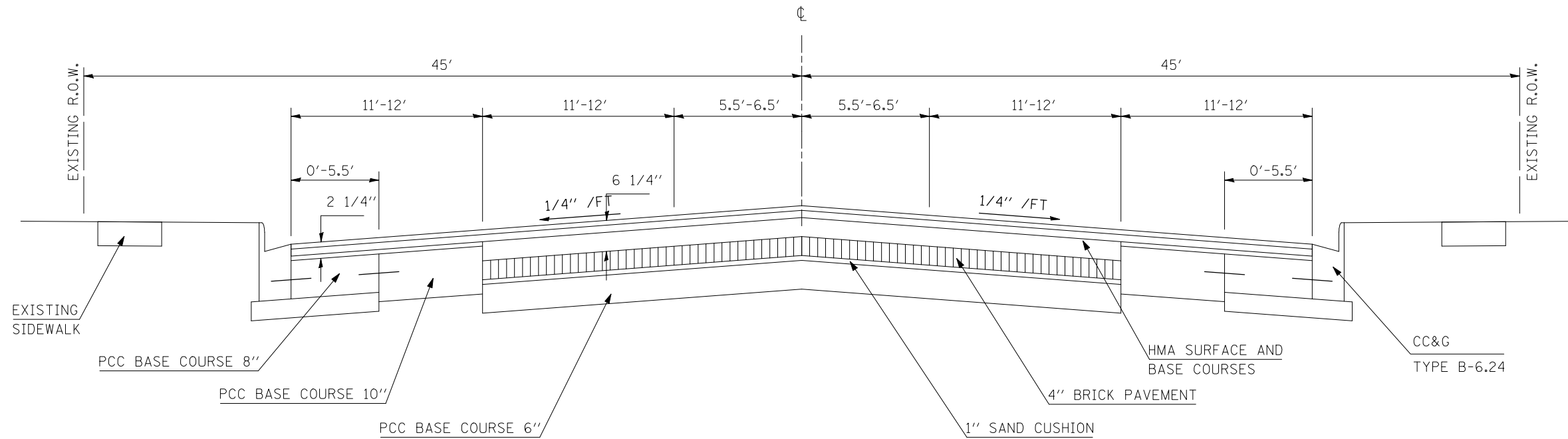

PROPOSED TYPICAL SECTION

STA. 21 + 04.30 TO STA. 27 + 60

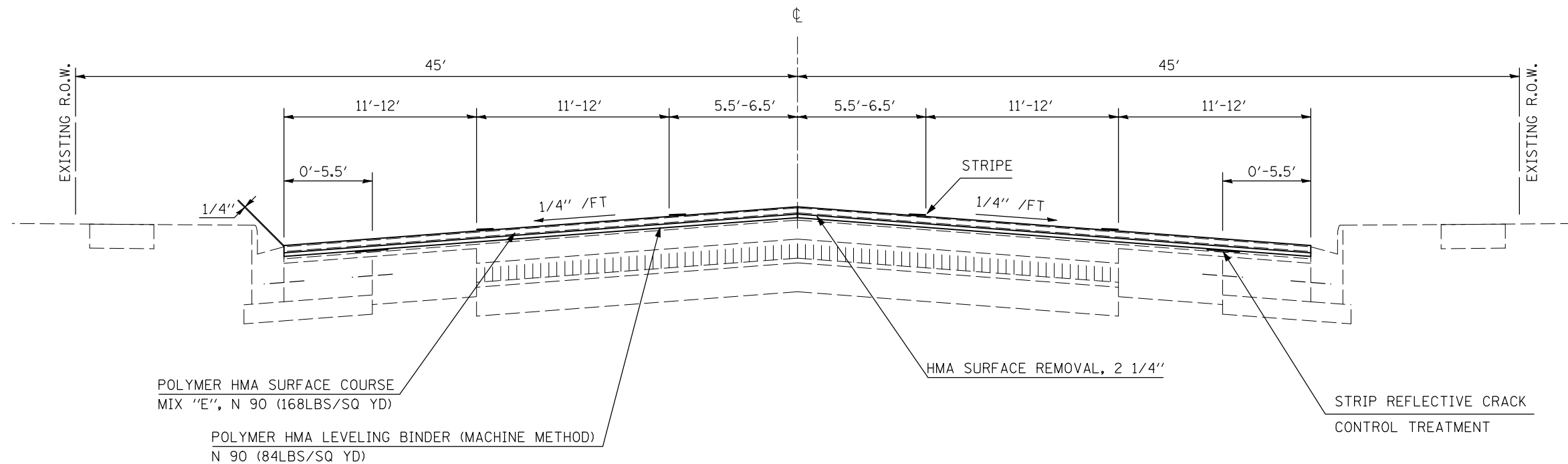

FILE NAME =	USER NAME = bucklesjj	DESIGNED -	REVISED -
ct:\pw\work\PWIDOT\BUCKLESJJ\d0184908\0970784-sht-Typicals.dgn		DRAWN -	REVISED -
		CHECKED -	REVISED -
		DATE -	REVISED -

**STATE OF ILLINOIS
DEPARTMENT OF TRANSPORTATION**

TYPICAL SECTIONS

SCALE: SHEET NO. OF SHEETS STA. TO STA.

F.A.P. RTE.	SECTION	COUNTY	TOTAL SHEETS	SHEET NO.
332	47RS-5	VERMILION	41	9
CONTRACT NO. 70784				
ILLINOIS FED. AID PROJECT				

EXISTING TYPICAL SECTION

STA. 27+60 TO STA. 29+55.91 (BK)

STA. 1029+55.91 (AH) TO STA. 1043+49

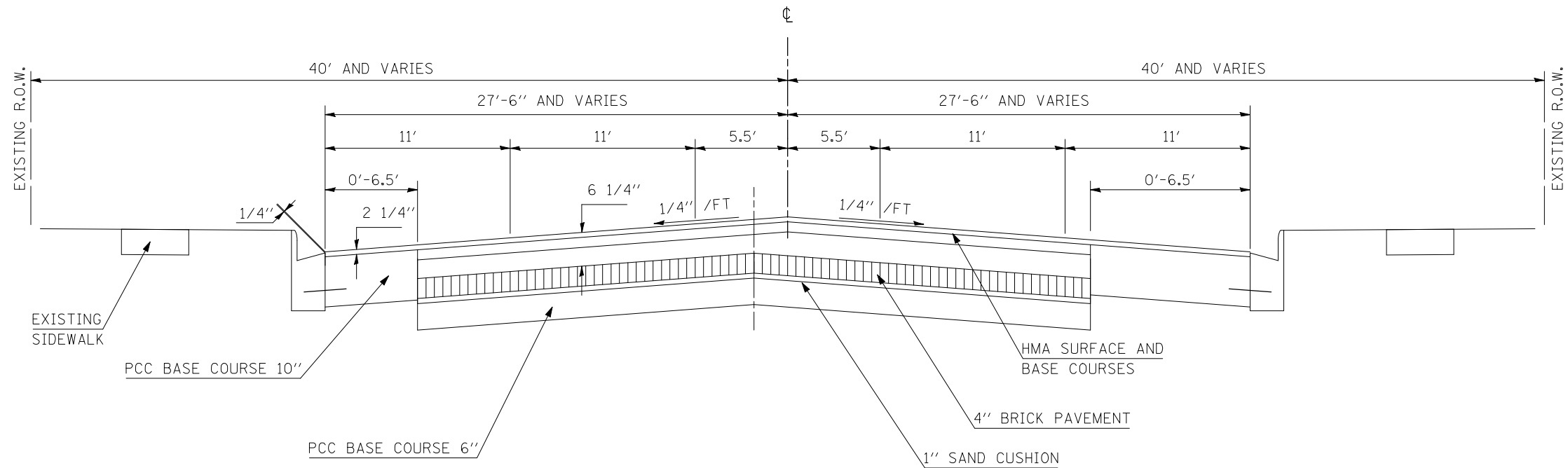

PROPOSED TYPICAL SECTION

STA. 27+60 TO STA. 29+55.91 (BK)

STA. 1029+55.91 (AH) TO STA. 1043+49

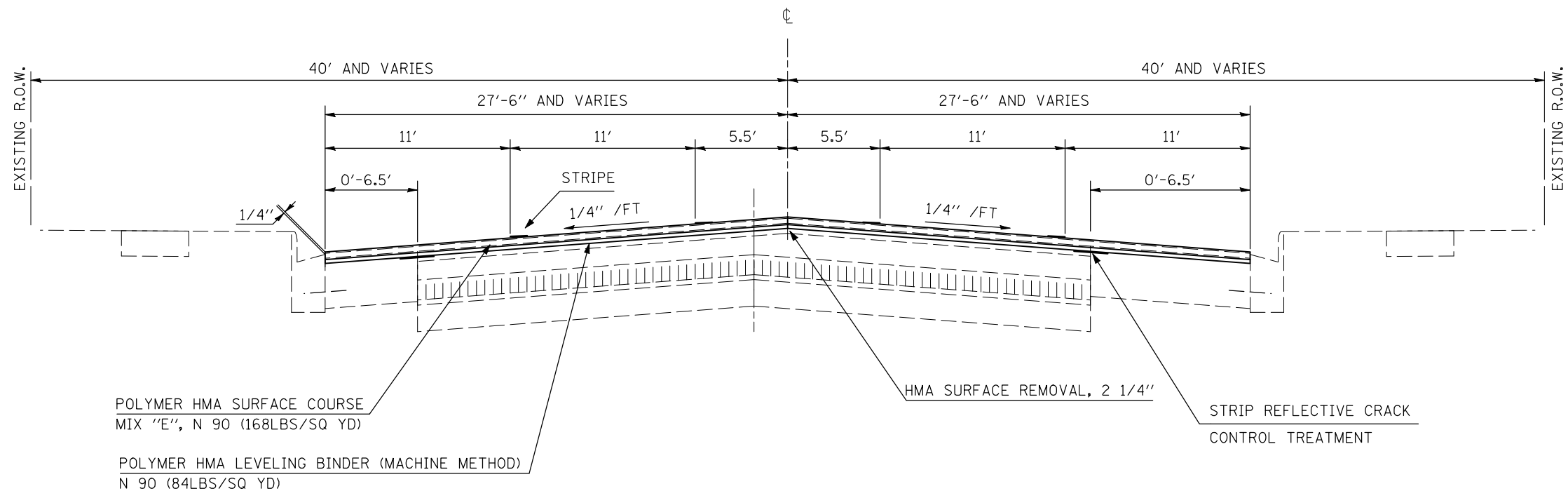

FILE NAME =	USER NAME = bucklesjj	DESIGNED -	REVISED -
ct:\pw\work\PWIDOT\BUCKLESJJ\d0184908\0570784-sht-Typicals.dgn		DRAWN -	REVISED -
		CHECKED -	REVISED -
		DATE -	REVISED -

**STATE OF ILLINOIS
DEPARTMENT OF TRANSPORTATION**

TYPICAL SECTIONS

SCALE: SHEET NO. OF SHEETS STA. TO STA.

F.A.P. RTE.	SECTION	COUNTY	TOTAL SHEETS	SHEET NO.
332	47RS-5	VERMILION	41	10
CONTRACT NO. 70784				
ILLINOIS FED. AID PROJECT				

EXISTING TYPICAL SECTION

STA. 1043+49 TO STA. 1048+97.43 (BK)

STA. 48+97.72 (AH) TO STA. 53+26.56

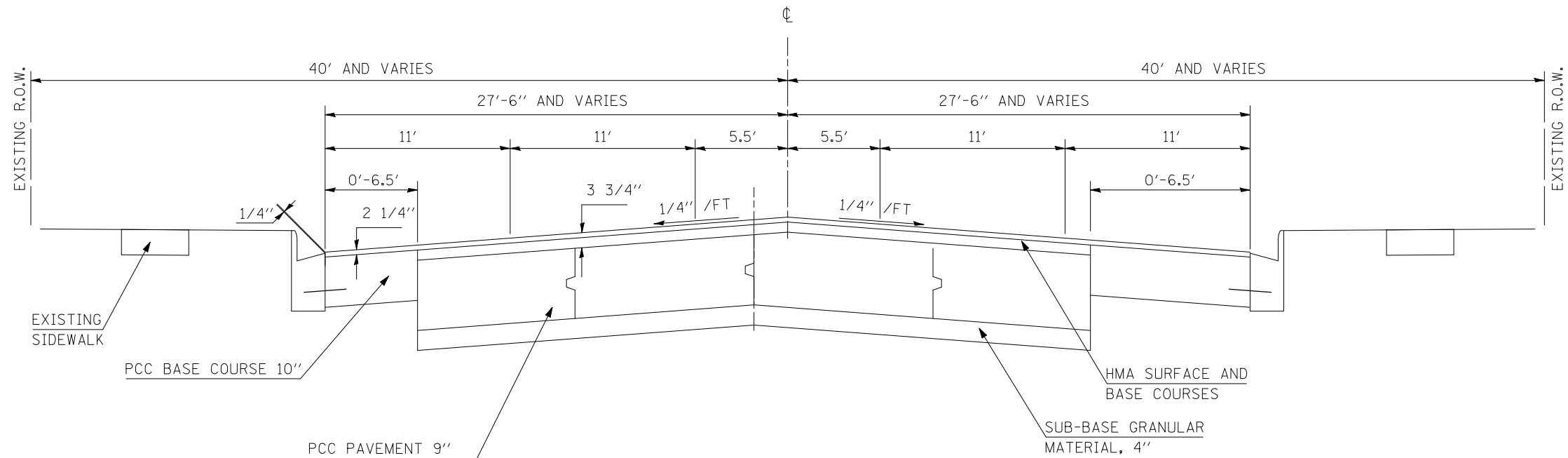

PROPOSED TYPICAL SECTION

STA. 1043+49 TO STA. 1048+97.43 (BK)

STA. 48+97.72 (AH) TO STA. 53+26.56

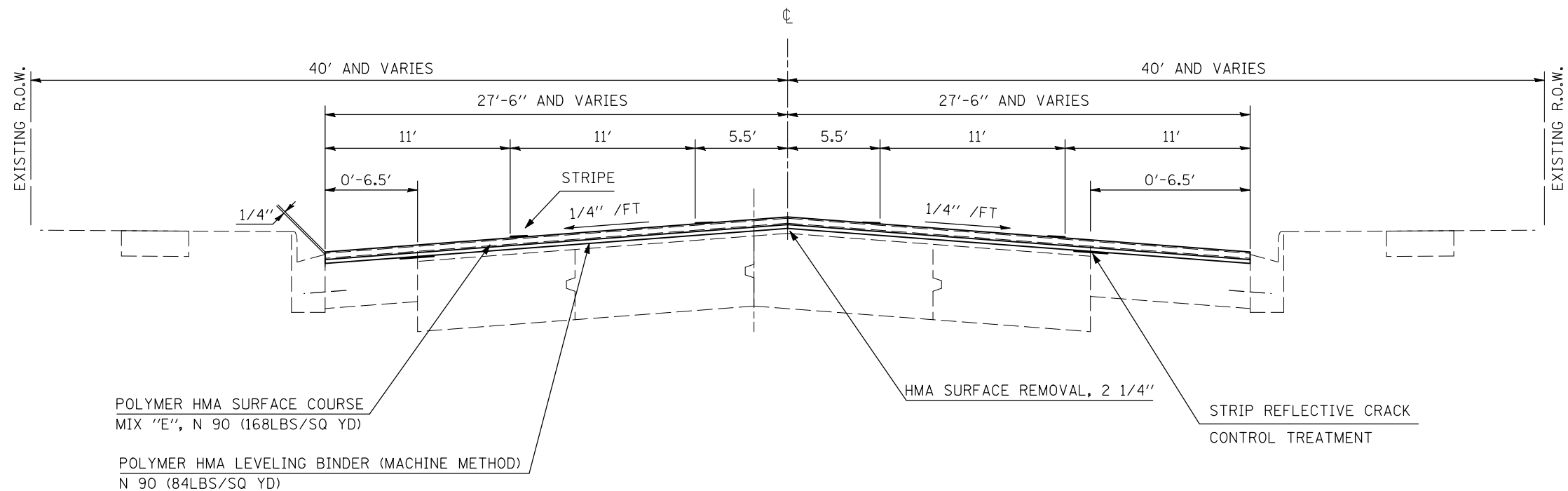

FILE NAME =	USER NAME = bucklesjj	DESIGNED -	REVISED -	STATE OF ILLINOIS DEPARTMENT OF TRANSPORTATION	TYPICAL SECTIONS			F.A.P. RTE.	SECTION	COUNTY	TOTAL SHEETS	SHEET NO.
ct:\pw\work\PWIDOT\BUCKLESJJ\d0184908.D	70784-sht-Typicals.dgn	DRAWN -	REVISED -					332	47RS-5	VERMILION	41	11
	PLOT SCALE = 40.0000' / IN.	CHECKED -	REVISED -		SCALE: SHEET NO. OF SHEETS STA. TO STA.			CONTRACT NO. 70784				
	PLOT DATE = 3/15/2010	DATE -	REVISED -		ILLINOIS FED. AID PROJECT							

CLASS D PATCHING

STATION	DIRECTION	LANE	LENGTH	WIDTH	CLASS "D"	CLASS "D"	STATION	DIRECTION	LANE	LENGTH	WIDTH	CLASS "D"	CLASS "D"	CLASS "D"	CLASS "D"
					TY II, 14" (SQ YDS)	TY III, 14" (SQ YDS)						TY I, 17" (SQ YDS)	TY II, 17" (SQ YDS)	TY III, 17" (SQ YDS)	TY IV, 17" (SQ YDS)
3033+11.5	NB	DL	12.0	12.0		16.0	29+06	NB	DL	6.0	11.0		7.33		
3033+11.5	NB	PL	12.0	12.0		16.0	29+33	NB	DL	6.0	11.0		7.33		
3033+11.5	SB	DL	12.0	12.0		16.0	1029+65	NB	DL	6.0	11.0		7.33		
3033+11.5	SB	PL	12.0	12.0		16.0	1029+86	NB	DL	6.0	11.0		7.33		
3035+43	SB	RAMP	6.0	12.0	8.0		1030+17	SB	DL	6.0	11.0		7.33		
3036+54	NB	RAMP	6.0	12.0	8.0		1030+22	NB	DL	6.0	11.0		7.33		
3036+94	SB	RAMP	6.0	12.0	8.0		1030+53	NB	DL	4.0	11.0	4.89			
3040+11	SB	RAMP	6.0	12.0	8.0		1030+89	NB	DL	6.0	11.0		7.33		
3040+30	SB	RAMP	6.0	12.0	8.0		1031+18	NB	DL	6.0	11.0		7.33		
3040+63	NB	DL	6.0	12.0	8.0		1031+42	NB	PL	6.0	11.0		7.33		
3040+63	NB	PL	6.0	12.0	8.0		1032+32	NB	DL	6.0	11.0		7.33		
3041+54	NB	DL	6.0	12.0	8.0		1032+71	NB	DL	30.0	11.0				36.67
3041+54	NB	PL	6.0	12.0	8.0		1033+16	NB	DL	6.0	11.0		7.33		
3046+73	SB	RAMP	6.0	12.0	8.0		1033+91	NB	DL	6.0	11.0		7.33		
3049+35	NB	DL	6.0	12.0	8.0		1034+46	NB	DL	6.0	11.0		7.33		
3049+35	NB	PL	6.0	12.0	8.0		1034+71	NB	DL	4.0	11.0	4.89			
3050+24	NB	DL	6.0	12.0	8.0		1034+97	NB	DL	6.0	11.0		7.33		
3050+24	NB	PL	6.0	12.0	8.0		1036+21	NB	DL	4.0	11.0	4.89			
3051+20	SB	RAMP	6.0	12.0	8.0		1040+17	NB	DL	6.0	11.0		7.33		
3051+28	NB	PL	6.0	12.0	8.0		1040+64	NB	DL	6.0	11.0		7.33		
3057+66	SB	RAMP	6.0	12.0	8.0		1040+96	NB	DL	6.0	11.0		7.33		
3058+23	NB	RAMP	6.0	12.0	8.0		1041+24	NB	DL	4.0	11.0	4.89			
3058+67	NB	RAMP	6.0	12.0	8.0		1041+37	NB	DL	6.0	11.0		7.33		
3058+67	NB	DL	6.0	12.0	8.0		1041+67	NB	DL	6.0	11.0		7.33		
3058+67	NB	PL	6.0	12.0	8.0		1041+91	NB	DL	6.0	11.0		7.33		
TOTAL=					168.0	64.0	1042+15	NB	DL	6.0	11.0		7.33		
USE=					168.0	64.0	1042+46	NB	DL	16.0	11.0			19.56	
					SQ YDS	SQ YDS	1042+53	NB	PL	6.0	11.0		7.33		
							1043+84	NB	DL	16.0	11.0			19.56	
							1044+70	NB	DL	10.0	11.0		12.22		
							49+72	NB	DL	4.0	11.0	4.89			
TOTAL=												24.45	173.48	39.12	36.67
USE=												25.0	174.0	40.0	37.0
												SQ YDS	SQ YDS	SQ YDS	SQ YDS

HOT-MIX ASPHALT

STATION	TO	STATION	LENGTH (FT)	WIDTH (FT)	AREA (SQ YD)	SURFACE THICKNESS (IN)	POLYMER LEVEL BINDER THICKNESS (IN)	40600100 BIT MATL PRIME (GAL)	40600300 AGG PR COAT (TON)	40603570 POLY HMA SC MIX "E" N90 (TON)	40600845 POLYMER LB (MM) (TON)	
3026+00.00		3041+70.00	1570.0	VAR	10030.79	1.5	0.75	1003.08	20.06	842.59	421.29	
BRIDGE OMISSION												
3043+70.00		3052+85.00	915.0	54.0	5392.50	1.5	0.75	539.25	10.79	452.97	226.49	
BRIDGE OMISSION												
3056+36.00		3061+50.00	514.0	54.0	2941.22	1.5	0.75	294.12	5.88	247.06	123.53	
CONCRETE SECTION OMISSION												
<u>E 16TH ST AUX LN</u>												
RT	3029+03.00	3030+68.40	165.4	VAR	148.55	1.5	0.75	14.86	0.30	12.48	6.24	
<u>W 16TH ST AUX LN</u>												
LT	3027+82.60	3029+61.10	178.5	VAR	294.50	1.5	0.75	29.45	0.59	24.74	12.37	
<u>14TH ST ACCEL LN & RAMP</u>												
LT	3033+19.80	3036+91.80	372.0	VAR	477.62	1.5	0.75	47.76	0.96	40.12	20.06	
<u>14TH ST DECEL LN & RAMP</u>												
RT	3033+64.60	3038+60.00	495.4	VAR	661.46	1.5	0.75	66.15	1.32	55.56	27.78	
<u>14TH ST DECEL LN & RAMP</u>												
LT	3039+12.10	3041+70.00	257.9	VAR	473.25	1.5	0.75	47.33	0.95	39.75	19.88	
<u>14TH ST ACCEL LN & RAMP</u>												
RT	3040+63.00	3041+70.00	107.0	VAR	271.51	1.5	0.75	27.15	0.54	22.81	11.40	
<u>I-74 ACCEL LN & RAMP</u>												
LT	3043+70.00	3046+97.60	327.6	VAR	652.62	1.5	0.75	65.26	1.31	54.82	27.41	
<u>I-74 DECEL LN & RAMP</u>												
RT	3043+70.00	3048+96.50	526.5	VAR	908.54	1.5	0.75	90.85	1.82	76.32	38.16	
<u>I-74 DECEL LN & RAMP</u>												
LT	3048+41.80	3052+85.00	443.2	VAR	541.47	1.5	0.75	54.15	1.08	45.48	22.74	
<u>I-74 ACCEL LN & RAMP</u>												
RT	3051+62.00	3052+85.00	123.0	VAR	260.24	1.5	0.75	26.02	0.52	21.86	10.93	
<u>I-74 ACCEL LN & RAMP</u>												
LT	3056+36.00	3057+67.20	131.2	VAR	297.91	1.5	0.75	29.79	0.60	25.02	12.51	
<u>I-74 DECEL LN & RAMP</u>												
RT	3056+36.00	3060+61.40	425.4	VAR	598.99	1.5	0.75	59.90	1.20	50.32	25.16	
<u>I-74 DECEL LN & RAMP</u>												
LT	3059+39.10	3061+50.00	210.9	VAR	128.88	1.5	0.75	12.89	0.26	10.83	5.41	
	21+04.30	27+60.00	655.7	VAR	4700.35	1.5	0.75	470.04	9.40	394.83	197.41	
	27+60.00	53+26.56	2566.5	55	15684.17	1.5	0.75	1568.42	31.37	1317.47	658.74	
					44464.57			4446.46	88.93	3735.02	1867.51	
								<u>USE =</u>	4447.0	89.0	3735.0	1868.0

40600982 HMA SURFACE REMOVAL - BUTT JOINT

STATION	LENGTH (FT)	WIDTH (FT)	(SQ YDS)
E 16TH ST	10.0	VAR	38.28
W 16TH ST	29.9	VAR	125.75
W 3RD ST	35.0	VAR	186.15
E 3RD ST	35.0	VAR	204.43
E 2ND ST	35.0	VAR	183.04
W 2ND ST	35.0	VAR	189.26
W 1ST ST	35.0	VAR	181.48
E 1ST ST	35.0	VAR	181.48
W BRIDGE ST	35.0	VAR	181.48
E BRIDGE ST	35.0	VAR	181.48
W BLUFF ST	40.0	VAR	215.37
E BLUFF ST	40.0	VAR	215.37
TOTAL =			2083.57
USE =			2085.0

*40600990 TEMPORARY RAMP

STATION	L (FT)	W (FT)	AFTER MILL		AFTER LEVEL BIND		L (FT)	W (FT)	AFTER	
			AREA (SQ YDS)	THICK	AREA (SQ YDS)	THICK				
3026+00	71.50	7.50	59.58	2.25	71.50	5.00	39.72	1.50		
E 16TH ST	25.70	5.00	14.28	1.50						
W 16TH ST	31.90	5.00	17.72	1.50						
LT 3037+29.1 (RAMP)	12.00	7.50	10.00	2.25	12.00	5.00	6.67	1.50		
RT 3037+73 (RAMP)	13.00	7.50	10.83	2.25	13.00	5.00	7.22	1.50		
LT 3039+83 (RAMP)	15.00	7.50	12.50	2.25	15.00	5.00	8.33	1.50		
RT 3040+18 (RAMP)	13.00	7.50	10.83	2.25	13.00	5.00	7.22	1.50		
3041+70	86.30	7.50	71.92	2.25	86.30	5.00	47.94	1.50		
3043+70	83.40	7.50	69.50	2.25	83.40	5.00	46.33	1.50		
LT 3047+13 (RAMP)	15.90	7.50	13.25	2.25	15.90	5.00	8.83	1.50		
RT 3046+93 (RAMP)	13.50	7.50	11.25	2.25	13.50	5.00	7.50	1.50		
LT 3050+80 (RAMP)	15.00	7.50	12.50	2.25	15.00	5.00	8.33	1.50		
RT 3058+31 (RAMP)	15.00	7.50	12.50	2.25	15.00	5.00	8.33	1.50		
3052+85	83.30	7.50	69.42	2.25	83.30	5.00	46.28	1.50		
3056+36	83.30	7.50	69.42	2.25	83.30	5.00	46.28	1.50		
3061+50	62.50	7.50	52.08	2.25	62.50	5.00	34.72	1.50		
CONCRETE OMISSION										
21+04.3	55.00	7.50	45.83	2.25	55.00	5.00	30.56	1.50		
W 4TH ST	134.00	3.00	44.67	2.25	134.00	2.00	29.78	1.50		
E 4TH ST	154.00	7.50	128.33	2.25	154.00	5.00	85.56	1.50		
W 3RD ST	27.20	5.00	15.11	1.50						
E 3RD ST	31.90	5.00	17.72	1.50						
W 2ND ST	26.40	5.00	14.67	1.50						
E 2ND ST	28.00	5.00	15.56	1.50						
W 1ST ST	26.00	5.00	14.44	1.50						
E 1ST ST	26.00	5.00	14.44	1.50						
W BRIDGE ST	26.00	5.00	14.44	1.50						
E BRIDGE ST	26.00	5.00	14.44	1.50						
W BLUFF ST	26.00	5.00	14.44	1.50						
E BLUFF ST	51.00	5.00	28.33	1.50						
53+26.5	55.0	7.5	45.83	2.25	55.0	5.00	30.56	1.50		
TOTAL=			945.86				500.17			
USE=					1446 SQ YDS					

*PLAN NOTE: TEMPORARY RAMPS SHALL BE USED ST LOCATIONS SHOWN IN THE PLANS
 IT IS THE INTENTION TO USE TEMPORARY RAMPS FOR MAJOR SIDE ROADS,
 AND LOCATIONS WHERE BITUMINOUS SURFACE REMOVAL 2.25" AND BUTT JOINTS ARE CONSTRUCTED.
 TEMPORARY RAMPS SHALL NOT BE USED AT MINOR TOWNSHIP ROADS, PRIVATE ENTRANCES,
 AND COMMERCIAL ENTRANCES.

FILE NAME =	USER NAME = bucklesJJ	DESIGNED -	REVISED -	STATE OF ILLINOIS DEPARTMENT OF TRANSPORTATION	SCHEDULES				F.A.P. RTE.	SECTION	COUNTY	TOTAL SHEETS	SHEET NO.
ct:\pw\work\PWIDOT\BUCKLESJJ\d0184908\0570784-sht-Schedules.dgn		DRAWN -	REVISED -						332	47RS-5	Vermillion	41	14
PLOT SCALE = 40.0000' / IN.		CHECKED -	REVISED -		CONTRACT NO. 70784				ILLINOIS FED. AID PROJECT				
PLOT DATE = 3/15/2010		DATE -	REVISED -		SCALE:	SHEET NO.	OF SHEETS	STA.	TO STA.				

40800050 INCIDENTAL HMA SURFACING

STATION	SQ YDS	INCHES	TONS	GALLONS	TONS
	AREA	AVERAGE THICKNESS	SIDEROAD	40800010 BIT MATLS PR CT	40800030 AGG PR CT
E 16TH ST	38.28	1.875	3.2	3.8	0.08
W 16TH ST	125.75	1.875	10.6	12.6	0.25
W 3RD ST	186.15	1.875	15.6	18.6	0.37
E 3RD ST	204.43	1.875	17.2	20.4	0.41
W 2ND ST	183.04	1.875	15.4	18.3	0.37
E 2ND ST	189.26	1.875	15.9	18.9	0.38
W 1ST ST	181.48	1.875	15.2	18.1	0.36
E 1ST ST	181.48	1.875	15.2	18.1	0.36
W BRIDGE ST	181.48	1.875	15.2	18.1	0.36
E BRIDGE ST	181.48	1.875	15.2	18.1	0.36
W BLUFF ST	215.37	1.875	18.1	21.5	0.43
E BLUFF ST	215.37	1.875	18.1	21.5	0.43
TOTAL =	2083.6	1.875	175.0	208.4	4.2
USE =			175.0	209.0	5.00

60300305 FRAMES AND LIDS TO BE ADJUSTED

STATION	EA	
LT 3027+55	1.0	
LT 3029+00	1.0	
LT 1031+70	1.0	
RT 1032+80	1.0	TELE
LT 1035+60	1.0	
RT 1036+60	1.0	
LT 1039+67	1.0	
RT 1040+43	1.0	TELE
LT 1043+67	1.0	
RT 1046+58	1.0	
RT 1046+70	1.0	TELE
LT 1048+58	1.0	
LT 1048+62	1.0	
RT 1048+65	1.0	
RT 1048+80	1.0	
LT 1049+05	1.0	
RT 50+62	1.0	
CL 51+20	1.0	
TOTAL =	18.0	
USE =	18.0 EACH	

44000158 HMA SURFACE REMOVAL, 2.25

STATION	TO	STATION	LENGTH (FT)	WIDTH (FT)	AREA (SQ YD)
3026+00.00		3041+70.00	1570.0	VAR	10030.79
BRIDGE OMISSION					
3043+70.00		3052+85.00	915.0	54.0	5392.50
BRIDGE OMISSION					
3056+36.00		3061+50.00	514.0	54.0	2941.22
CONCRETE SECTION OMISSION					
E 16TH ST AUX LN					
RT 3029+03.00		3030+68.40	165.4	VAR	148.55
W 16TH ST AUX LN					
LT 3027+82.60		3029+61.10	178.5	VAR	294.50
14TH ST ACCEL LN & RAMP					
LT 3033+19.80		3036+91.80	372.0	VAR	477.62
14TH ST DECEL LN & RAMP					
RT 3033+64.60		3038+60.00	495.4	VAR	661.46
14TH ST DECEL LN & RAMP					
LT 3039+12.10		3041+70.00	257.9	VAR	473.25
14TH ST ACCEL LN & RAMP					
RT 3040+63.00		3041+70.00	107.0	VAR	271.51
I-74 ACCEL LN & RAMP					
LT 3043+70.00		3046+97.60	327.6	VAR	652.62
I-74 DECEL LN & RAMP					
RT 3043+70.00		3048+96.50	526.5	VAR	908.54
I-74 DECEL LN & RAMP					
LT 3048+41.80		3052+85.00	443.2	VAR	541.47
I-74 ACCEL LN & RAMP					
RT 3051+62.00		3052+85.00	123.0	VAR	260.24
I-74 ACCEL LN & RAMP					
LT 3056+36.00		3057+67.20	131.2	VAR	297.91
I-74 DECEL LN & RAMP					
RT 3056+36.00		3060+61.40	425.4	VAR	598.99
I-74 DECEL LN & RAMP					
LT 3059+39.10		3061+50.00	210.9	VAR	128.88
21+04.30		27+60.00	655.7	VAR	4700.35
27+60.00		53+26.56	2566.5	55	15684.17
TOTAL =					44464.57
USE =					44465 SQ YDS

44300200 STRIP REFLECTIVE CRACK CONTROL TREATMENT

STATION	TO	STATION	FT
RT 3029+60		3038+60	900.0
LT 3029+60		3037+12	752.0
RT 3040+61		3041+70	109.0
LT 3039+12		3041+70	258.0
RT 3043+70		3048+96	526.0
LT 3043+70		3046+97	327.0
RT 3051+59		3052+86	127.0
LT 3048+42		3052+86	444.0
RT 3056+36		3060+60	424.0
LT 3056+36		3057+67	131.0
LT 3059+39		3061+50	211.0
CONC OMISSION			
RT 21+04.3		29+55.9 (BK)	851.6
RT 1029+51.91 (AHD)		1048+97.43 (BK)	1945.5
RT 48+97.72 (AHD)		53+26.56	428.8
LT 21+04.3		29+55.9 (BK)	851.6
LT 1029+51.91 (AHD)		1048+97.43 (BK)	1945.5
LT 48+97.72 (AHD)		53+26.56	428.8
TOTAL=			10660.8
USE=			10661.0 FEET

60300405 VALVE BOX FRAMES TO BE ADJUSTED

STATION	EA
LT 3033+22	1.0
LT 3038+45	1.0
LT 3038+65	1.0
LT 23+98	1.0
LT 24+37	1.0
LT 25+88	1.0
LT 26+70	1.0
RT 28+20	1.0
LT 29+30	1.0
RT 32+65	1.0
RT 35+60	1.0
LT 35+65	1.0
LT 1040+00	1.0
TOTAL= 13.0	
USE= 13.0 EACH	

XZ193400 SURVEY MARKER TY2 (SPECIAL)

STATION		EA
3028+24.08	(POT)	1.0
3034+61.37	(POT)	1.0
3041+61.66	(POT)	1.0
3044+79.14	(PI)	1.0
TOTAL=		4.0
USE=		4.0 EACH

Z0070100 SURVEY MONUMENT COVER ASSEMBLY

STATION		EA
CL 29+55.91		1.0
CL 1043+79.57	(PC)	1.0
RT 1046+38.5	(PI)	1.0
CL 1048+97.43	(PT)	1.0
CL 3028+32.14	(PI)	1.0
TOTAL=		5.0
USE=		5.0 EACH

78000100 THERMOPLASTIC PAVEMENT MARKING LETTERS AND SYMBOLS

78000200 THERMOPLASTIC PAVEMENT MARKING, LINE 4"- YELLOW

78000200 THERMOPLASTIC PAVEMENT MARKING, LINE 4"- YELLOW (cont'd)

STATION	TYPE	SQ.FT	STATION	TO	STATION	LINE TYPE	FEET	STATION	TO	STATION	LINE TYPE	FEET
CL 3026+65	ARROW	15.6	RT 3026+00		RT 3027+68	SOLID	168.0	RT 28+48		RT 29+55.91 (BK)	SOLID	107.9
CL 3027+98	ARROW	15.6	LT 3026+00		LT 3027+68	SOLID	168.0	RT 1029+55.91 (AHD)		RT 1031+42	SOLID	186.1
CL 3028+80	ARROW	15.6	RT 3026+00		RT 3027+68	SKIP DASH	50.0	RT 28+48		RT 29+55.91 (BK)	SKIP DASH	30.0
CL 3029+95	ARROW	15.6	LT 3026+00		LT 3027+68	SKIP DASH	50.0	RT 1029+55.91 (AHD)		RT 1031+42	SKIP DASH	50.0
CL 3030+77	ARROW	15.6	LT 3027+68		LT 3029+00	DBL SOLID	264.0	LT 28+48		LT 29+55.91 (BK)	SOLID	107.9
CL 21+50	DBL ARROW	31.2	RT 3029+75		RT 3041+70	SOLID	1195.0	LT 1029+55.91 (AHD)		LT 1031+42	SOLID	186.1
CL 22+59	ARROW	31.2	RT 3026+75		LT 3041+70	SOLID	1195.0	LT 28+48		LT 29+55.91 (BK)	SKIP DASH	30.0
CL 23+07	ARROW	31.2	RT 3037+44 (RAMP)		RT 3037+72	SOLID	30.0	LT 1029+55.91 (AHD)		LT 1031+42	SKIP DASH	50.0
CL 23+54	ARROW	31.2	LT 3037+12 (RAMP)		LT 3037+42	SOLID	30.0	RT 1032+41		RT 1035+21	SOLID	280.0
CL 25+04	ARROW	15.6	RT 3040+32 (RAMP)		RT 3040+62	SOLID	30.0	RT 1032+41		RT 1035+21	SKIP DASH	70.0
CL 25+52	ARROW	15.6	LT 3039+77 (RAMP)		LT 3040+07	SOLID	30.0	LT 1032+41		LT 1035+21	SOLID	280.0
CL 25+99	ARROW	15.6	RT 3043+70		RT 3053+85	SOLID	1015.0	LT 1032+41		LT 1035+21	SKIP DASH	70.0
CL 27+07	ARROW	15.6	LT 3043+70		LT 3053+85	SOLID	1015.0	RT 1036+18		RT 1039+38	SOLID	320.0
CL 28+90	DBL ARROW	31.2	RT 3046+72 (RAMP)		RT 3047+02	SOLID	30.0	RT 1036+18		RT 1039+38	SKIP DASH	80.0
CL 1031+00	DBL ARROW	31.2	LT 3046+97 (RAMP)		LT 3051+62	SOLID	30.0	LT 1036+18		LT 1039+38	SOLID	320.0
CL 1032+83	DBL ARROW	31.2	RT 3051+32 (RAMP)		RT 3051+62	SOLID	30.0	LT 1036+18		LT 1039+38	SKIP DASH	80.0
CL 1034+79	DBL ARROW	31.2	LT 3050+76 (RAMP)		LT 3051+06	SOLID	30.0	RT 1040+34		RT 1048+12	SOLID	778.0
CL 1036+60	DBL ARROW	31.2	RT 3056+36		RT 3061+50	SOLID	514.0	RT 1040+34		RT 1048+12	SKIP DASH	200.0
CL 1038+96	DBL ARROW	31.2	LT 3056+36		LT 3061+50	SOLID	514.0	LT 1040+34		LT 1048+12	SOLID	778.0
CL 1040+76	DBL ARROW	31.2	RT 3058+06 (RAMP)		RT 3058+36	SOLID	30.0	LT 1040+34		LT 1048+12	SKIP DASH	200.0
CL 1043+07	DBL ARROW	31.2	LT 3057+68 (RAMP)		LT 3057+98	SOLID	30.0	RT 49+10		RT 53+26.56	SOLID	416.6
CL 1045+39	DBL ARROW	31.2	CONC OMISSION					RT 49+10		RT 53+26.56	SKIP DASH	110.0
CL 1047+68	DBL ARROW	31.2	RT 21+04.3		RT 22+00.0	SOLID	196.0	LT 49+10		LT 53+26.56	SOLID	416.6
CL 49+52	DBL ARROW	31.2	LT 21+04.3		LT 22+29	SOLID	96.0	LT 49+10		LT 53+26.56	SKIP DASH	110.0
CL 52+00	DBL ARROW	31.2	RT 21+04.3		RT 22+00.0	SKIP DASH	20.0	SUB TOTAL= 5257.2				
		TOTAL=	639.6	LT 21+04.3	LT 22+29	SKIP DASH	20.0					
		USE=	640.0 FEET	LT 22+29	LT 23+74	DBL SOLID	290.0	TOTAL= 12922.2 YELLOW				
				RT 24+84	RT 26+25	DBL SOLID	282					
				RT 26+25	RT 27+60.0	SOLID	135					
				RT 26+25	RT 27+60.0	SKIP DASH	40.0					
				LT 26+52	LT 27+60.0	SOLID	108.0					
				LT 26+52	LT 27+60.0	SKIP DASH	30.0					
				SUB TOTAL=			7665.0					

78000200 THERMOPLASTIC PAVEMENT MARKING, LINE 4"- WHITE

STATION	TO	STATION	LINE TYPE	FEET	
RT 3026+00		RT 3029+00	SOLID	300.0	
LT 3026+00		LT 3029+00	SOLID	300.0	
RT 3026+00		RT 3029+00	SKIP DASH	80.0	
LT 3026+00		LT 3029+00	SKIP DASH	80.0	
RT 3029+98		RT 3029+00	SOLID	102.0	
RT 3029+50		RT 3037+72	SOLID	822.0	
LT 3029+75		LT 3037+30	SOLID	787.0	
RT 3029+75		RT 3030+77	SOLID	102.0	
RT 3029+75		RT 3041+70	SKIP DASH	300.0	
LT 3029+75		LT 3041+70	SKIP DASH	300.0	
RT 3038+00		RT 3040+00	SOLID	200.0	
LT 3037+12		LT 3039+12	SOLID	200.0	
RT 3040+32		RT 3041+70	SOLID	138.0	
LT 3039+77		LT 3041+70	SOLID	193.0	
LT 3041+70		LT 3041+70	SKIP DASH	30.0	
RT 3043+70		RT 3047+02	SOLID	350.0	
LT 3043+70		LT 3047+27	SOLID	357.0	
RT 3043+70		RT 3052+85	SKIP DASH	230.0	
LT 3043+70		LT 3052+85	SKIP DASH	230.0	
LT 3047+47		LT 3050+80	SOLID	333.0	
RT 3047+00		RT 3051+00	SOLID	400.0	
RT 3051+32		RT 3052+85	SOLID	153.0	
LT 3050+76		LT 3052+85	SOLID	209.0	
RT 3043+70		RT 3044+56	SKIP DASH	20.0	
LT 3043+70		LT 3046+05	SKIP DASH	60.0	
LT 3051+81		LT 3052+85	SKIP DASH	20.0	
RT 3056+36		RT 3058+36	SOLID	200.0	
LT 3056+36		LT 3057+98	SOLID	162.0	
RT 3056+36		RT 3057+30	SKIP DASH	20.0	
LT 3056+36		LT 3056+91	SKIP DASH	20.0	
RT 3056+36		RT 3061+50	SKIP DASH	130.0	
LT 3056+36		LT 3061+50	SKIP DASH	130.0	
RT 3058+45		RT 3061+50	SOLID	305.0	
LT 3057+68		LT 3061+50	SOLID	382.0	
CONC OMISSION					
RT 21+04.3		RT 23+82	SKIP DASH	70.0	
LT 21+04.3		LT 23+82	SKIP DASH	70.0	
RT 22+59		RT 23+82	SOLID	123.0	RT TURN LN
RT 22+59		RT 23+82	SOLID	123.0	LT TURN LN
RT 24+84		RT 23+82	SKIP DASH	70.0	
LT 24+78		LT 27+60.0	SKIP DASH	70.0	
LT 24+78		LT 25+99.0	SOLID	121.0	
SUB TOTAL=				8272.0	

78000200 THERMOPLASTIC PAVEMENT MARKING, LINE 4"- WHITE (cont'd)

STATION	TO	STATION	LINE TYPE	FEET
RT 28+48		RT 29+55.91 (BK)		
RT 1029+55.91 (AHD)		RT 1031+42	SKIP DASH	80.0
LT 28+48		LT 29+55.91 (BK)		
LT 1029+55.91 (AHD)		LT 1031+42	SKIP DASH	80.0
RT 1032+41		RT 1035+21	SKIP DASH	70.0
LT 1032+41		LT 1035+21	SKIP DASH	70.0
RT 1036+18		RT 1039+33	SKIP DASH	80.0
LT 1036+18		LT 1039+33	SKIP DASH	80.0
RT 1040+34		RT 1048+12	SKIP DASH	200.0
LT 1040+34		LT 1048+12	SKIP DASH	200.0
RT 49+10		RT 53+26.56	SKIP DASH	150.0
LT 49+10		LT 53+26.56	SKIP DASH	150.0
SUB TOTAL=				1160.0
TOTAL=				9432.0 WHITE
TOTAL=				22354.2
USE=				22355 FEET

78000400 THERMOPLASTIC PAVEMENT MARKING, LINE 6" WHITE

STATION	TO	STATION	LINE TYPE	FEET
RT 23+86		LT 23+86	CROSSWALK	71.5
RT 23+92		LT 23+92	CROSSWALK	71.5
RT 24+67		LT 24+67	CROSSWALK	71.5
RT 24+73		LT 24+73	CROSSWALK	71.5
TOTAL=				286.0
USE=				286.0 FEET

78000500 THERMOPLASTIC PAVEMENT MARKING LINE 8"

(GORES)

WHITE

STATION	TO	STATION	LINE TYPE	FEET
RT 3068+08		RT 3038+00	SOLID	192.0
RT 3068+08		RT 3037+44	SOLID	136.0
LT 3034+98		LT 3037+12	SOLID	214.0
LT 3034+98		LT 3037+12	SOLID	214.0
RT 3040+00		RT 3041+67	SOLID	167.0
RT 3040+62		RT 3041+67	SOLID	106.0
LT 3039+12		LT 3040+79	SOLID	167.0
LT 3040+07		LT 3040+79	SOLID	79.0
RT 3044+56		RT 3047+00	SOLID	244.0
RT 3044+56		RT 3046+72	SOLID	218.0
LT 3046+05		LT 3046+97	SOLID	142.0
LT 3046+05		LT 3047+47	SOLID	93.0
RT 3051+00		RT 3052+46	SOLID	146.0
RT 3051+62		RT 3052+46	SOLID	84.0
LT 3050+80		LT 3051+81	SOLID	101.0
LT 3051+06		LT 3051+81	SOLID	75.0
RT 3057+30		RT 3058+45	SOLID	115.0
RT 3057+30		RT 3058+06	SOLID	80.0
LT 3056+91		LT 3057+68	SOLID	77.0
LT 3056+91		LT 3057+68	SOLID	78.0
TOTAL=				2728.0

USE= 2728 FEET

78000600 THERMOPLASTIC PAVEMENT MARKING LINE 12"

STATION	TO	STATION	LINE TYPE	FEET	
CL 3030+77		CL 3033+59	DIAGONAL	150.0	YELLOW
RT 3036+08		RT 3038+00	DIAGONAL	60.0	YELLOW
LT 3039+12		LT 3040+00	DIAGONAL	80.0	YELLOW
RT 3044+46		RT 3047+00	DIAGONAL	120.0	YELLOW
LT 3050+80		LT 3051+81	DIAGONAL	40.0	YELLOW
RT 3057+30		RT 3058+45	DIAGONAL	52.0	YELLOW
TOTAL=				502.0	
USE=				502.0 FEET	

78000650 THERMOPLASTIC PAVEMENT MARKING LINE 24"

STATION	TO	STATION	LINE TYPE	FEET	
LT 23+74		RT 23+74	STOP BAR	12.5	WHITE
RT 23+82		RT 23+82	STOP BAR	38.0	WHITE
LT 24+77		LT 24+77	STOP BAR	24.0	WHITE
LT 24+84		RT 24+84	STOP BAR	12.5	WHITE
TOTAL				85.0	

USE= 85.0 FEET



78100100 RAISED REFLECTIVE PAVEMENT MARKER

78100100 RAISED REFLECTIVE PAVEMENT MARKER (cont'd)

STATION	TO	STATION	LINE TYPE	EACH	
RT 3026+00		RT 3029+00	CRYSTAL ONE WAY	4.0	
LT 3026+00		LT 3029+00	CRYSTAL ONE WAY	4.0	
RT 3026+00		RT 3027+68	AMBER TWO WAY	4.0	40' CTRS
LT 3026+00		LT 3029+00	AMBER TWO WAY	8.0	40' CTRS
RT 3027+98		RT 3029+00	CRYSTAL ONE WAY	3.0	
RT 3029+75		RT 3041+70	CRYSTAL ONE WAY	15.0	
LT 3029+75		LT 3041+70	CRYSTAL ONE WAY	15.0	
LT 3029+75		LT 3030+77	CRYSTAL ONE WAY	3.0	
RT 3029+75		RT 3030+77	AMBER TWO WAY	6.0	DBL 40'CTRS
RT 3030+77		RT 3033+59	AMBER TWO WAY	7.0	40' CTRS
RT 3030+77		LT 3033+59	AMBER TWO WAY	7.0	40' CTRS
RT 3033+59		RT 3041+70	AMBER ONE WAY	10.0	
LT 3033+59		LT 3041+70	AMBER ONE WAY	10.0	
RT 3036+08		RT 3038+00	CRYSTAL ONE WAY	5.0	40' CTRS
RT 3036+08		RT 3038+72	CRYSTAL ONE WAY	5.0	40' CTRS
LT 3039+12		LT 3040+79	CRYSTAL ONE WAY	5.0	40' CTRS
LT 3039+07		LT 3040+79	CRYSTAL ONE WAY	3.0	40' CTRS
RT 3043+70		RT 3052+85	CRYSTAL ONE WAY	12.0	
LT 3043+70		LT 3052+85	CRYSTAL ONE WAY	12.0	
LT 3043+70		LT 3046+05	CRYSTAL ONE WAY	3.0	
RT 3043+70		RT 3052+85	AMBER ONE WAY	12.0	
LT 3043+70		LT 3052+85	AMBER ONE WAY	12.0	
RT 3044+56		RT 3047+00	CRYSTAL ONE WAY	7.0	40' CTRS
RT 3044+56		RT 3046+72	CRYSTAL ONE WAY	6.0	40' CTRS
LT 3050+80		LT 3051+81	CRYSTAL ONE WAY	3.0	40' CTRS
LT 3051+06		LT 3051+81	CRYSTAL ONE WAY	3.0	40' CTRS
RT 3056+36		RT 3061+50	CRYSTAL ONE WAY	7.0	
LT 3056+36		LT 3051+60	CRYSTAL ONE WAY	7.0	
RT 3056+36		RT 3061+50	AMBER ONE WAY	7.0	40' CTRS
LT 3056+36		LT 3051+60	AMBER ONE WAY	7.0	40' CTRS
RT 3057+30		RT 3058+45	CRYSTAL ONE WAY	4.0	
RT 3057+30		RT 3058+06	CRYSTAL ONE WAY	3.0	
CONC OMISSION					
RT 21+04.3		RT 23+82	CRYSTAL ONE WAY	4.0	
RT 21+04.3		RT 22+00	AMBER TWO WAY	3.0	40' CTRS
RT 22+59		RT 23+82	CRYSTAL ONE WAY	3.0	40' CTRS
RT 22+59		RT 23+82	CRYSTAL ONE WAY	3.0	40' CTRS
LT 21+04.3		LT 22+29	AMBER TWO WAY	3.0	40' CTRS
LT 22+29		LT 23+74	AMBER TWO WAY	3.0	40' CTRS
LT 21.04.3		LT 23+82	CRYSTAL ONE WAY	4.0	
RT 24+84		RT 27+60	CRYSTAL ONE WAY	4.0	
RT 24+84		RT 27+60	AMBER TWO WAY	7.0	40' CTRS
LT 24+76.5		LT 27+60	CRYSTAL ONE WAY	4.0	
LT 24+76.5		LT 25+99	AMBER TWO WAY	3.0	40' CTRS
26+51.5		27+60	CRYSTAL ONE WAY	3.0	40' CTRS
				SUB TOTAL=	263.0

STATION	TO	STATION	LINE TYPE	EACH	
RT 28+48		RT 1031+42	CRYSTAL ONE WAY	4.0	
RT 28+48		RT 1031+42	AMBER TWO WAY	8.0	40' CTRS
LT 28+48		LT 1031+42	CRYSTAL ONE WAY	4.0	
LT 28+48		LT 1031+42	AMBER TWO WAY	8.0	40' CTRS
RT 1032+41		RT 1035+21	CRYSTAL ONE WAY	4.0	
RT 1032+41		RT 1035+21	AMBER TWO WAY	8.0	40' CTRS
LT 1032+41		LT 1035+21	CRYSTAL ONE WAY	4.0	
LT 1032+41		LT 1035+21	AMBER TWO WAY	8.0	40' CTRS
RT 1036+18		RT 1039+38	CRYSTAL ONE WAY	4.0	
RT 1036+18		RT 1039+38	AMBER TWO WAY	8.0	40' CTRS
LT 1036+18		LT 1039+38	CRYSTAL ONE WAY	4.0	
LT 1036+18		LT 1039+38	AMBER TWO WAY	8.0	40' CTRS
RT 1040+34		RT 1048+12	CRYSTAL ONE WAY	10.0	
RT 1040+34		RT 1048+12	AMBER TWO WAY	20.0	40' CTRS
LT 1040+34		LT 1048+12	CRYSTAL ONE WAY	10.0	
LT 1040+34		LT 1048+12	AMBER TWO WAY	20.0	40' CTRS
RT 49+10		RT 53+26.56	CRYSTAL ONE WAY	6.0	
RT 49+10		RT 53+26.56	AMBER TWO WAY	12.0	40' CTRS
LT 49+10		LT 53+26.56	CRYSTAL ONE WAY	6.0	
LT 49+10		LT 53+26.56	AMBER TWO WAY	12.0	40' CTRS
				SUB TOTAL=	168.0
				USE=	431.0 EACH

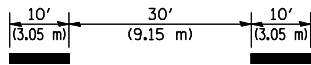
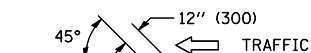
TYPICAL PAVEMENT MARKING LEGEND

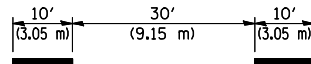
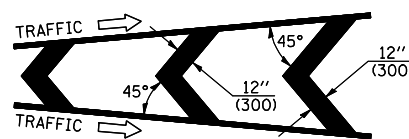
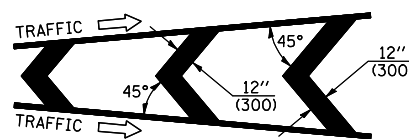
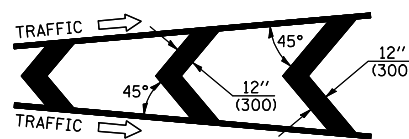
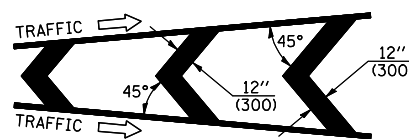
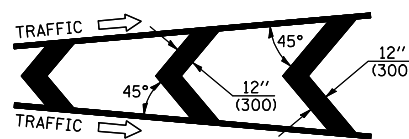
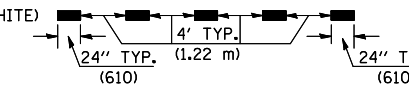
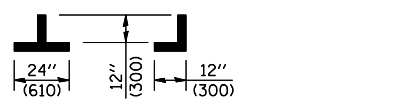
- 1 4" (100) SKIP-DASH (YELLOW) 
- 2 4" (100) SOLID (YELLOW) 
- 3 12" (300) DIAGONAL (YELLOW) 
- 4 4" (100) DOUBLE YELLOW (NARROW) 
- 5 RESERVED
- 6 RESERVED
- 7 4" (100) SKIP-DASH (WHITE) 
- 8 4" (100) SOLID (WHITE) 
- 9 12" (300) DIAGONAL (WHITE) 
- 10 6" (150) SOLID (WHITE) 
- 11 24" (600) STOP BAR (WHITE) 
- 12 8" (200) SOLID (WHITE) 
- 13 4" (100) LANE LINE EXTENSIONS (WHITE) 
- 14 4" (100) PARKING WHITE 

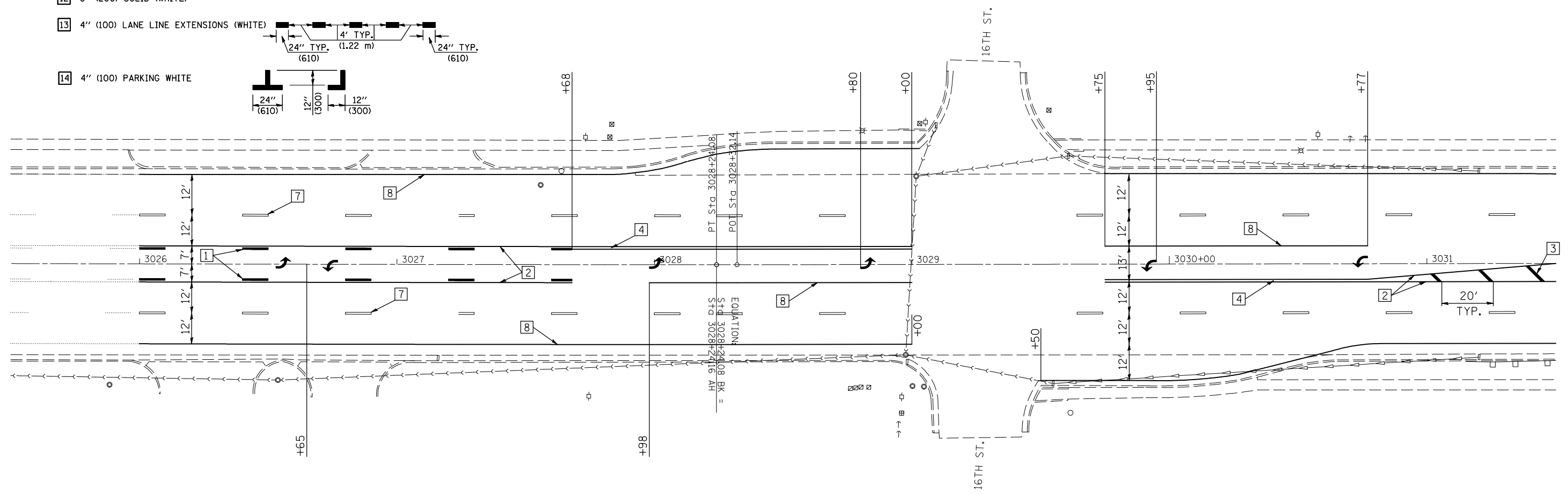

FILE NAME =	USER NAME = bucklesjj	DESIGNED -	REVISED -	STATE OF ILLINOIS DEPARTMENT OF TRANSPORTATION	STRIPING PLAN SHEET				F.A.P. RTE.	SECTION	COUNTY	TOTAL SHEETS	SHEET NO.
et\pw\work\PWIDOT\BUCKLESJJ\d0184889\0370784-sht-striping.dgn	70784-sht-striping.dgn	DRAWN -	REVISED -		332	47RS-5	Vermillion	41	21				
PLOT SCALE = 40.0000' / IN.	CHECKED -	REVISED -	REVISED -		CONTRACT NO. 70784								
PLOT DATE = 3/15/2010	DATE -	REVISED -	REVISED -		ILLINOIS FED. AID PROJECT								
				SCALE:	SHEET NO.	OF SHEETS	STA.	TO STA.					

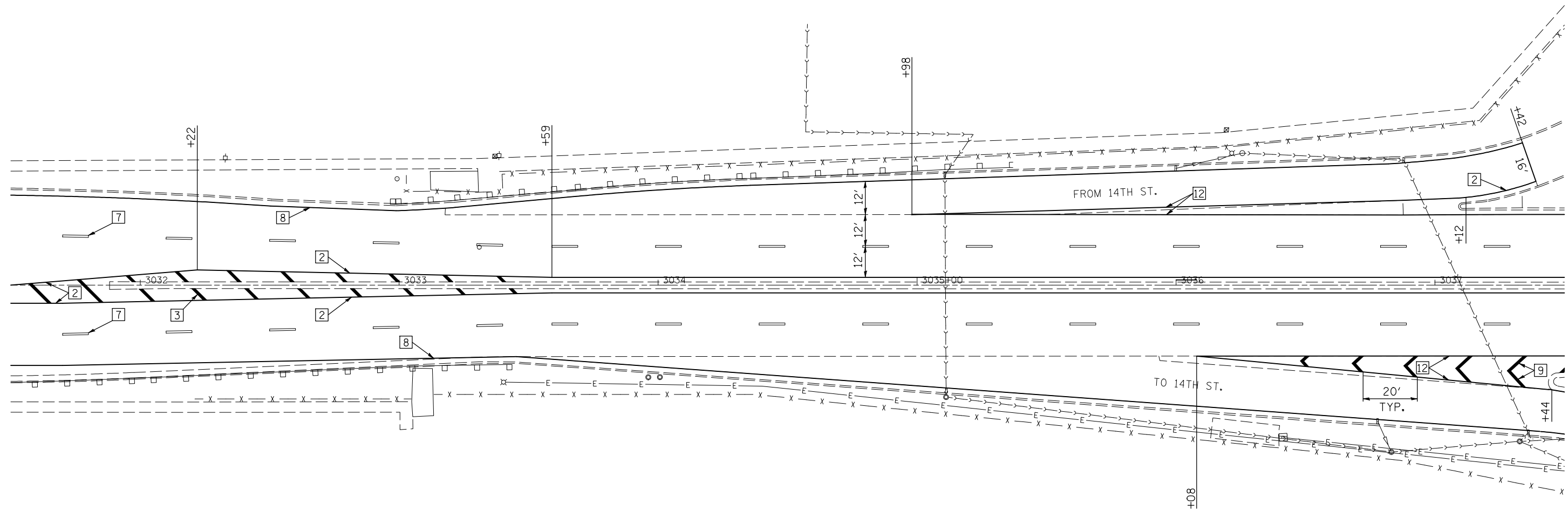
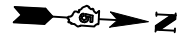

FILE NAME =	USER NAME = bucklesjj	DESIGNED -	REVISED -
ct\pw\work\PWIDOT\BUCKLESJJ\d0184889\070784-sht-striping.dgn		DRAWN -	REVISED -
	PLOT SCALE = 40.0000' / IN.	CHECKED -	REVISED -
	PLOT DATE = 3/15/2010	DATE -	REVISED -

**STATE OF ILLINOIS
DEPARTMENT OF TRANSPORTATION**

STRIPING PLAN SHEET

SCALE: SHEET NO. OF SHEETS STA. TO STA.

F.A.P. RTE.	SECTION	COUNTY	TOTAL SHEETS	SHEET NO.
332	47RS-5	Vermillion	41	22
ILLINOIS FED. AID PROJECT			CONTRACT NO. 70784	

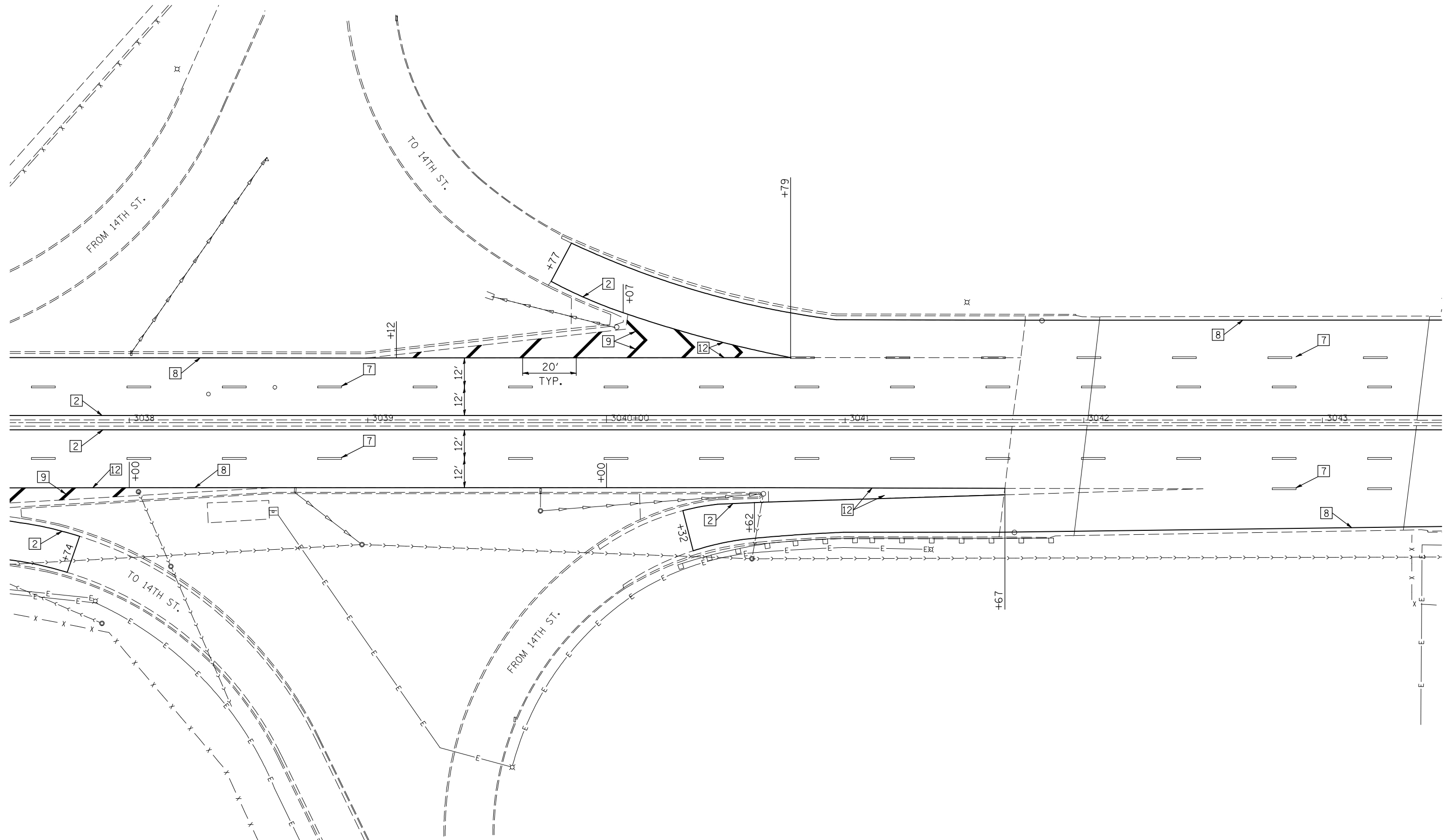

FILE NAME =	USER NAME = bucklesJJ	DESIGNED -	REVISED -
ct:\pw\work\PWIDOT\BUCKLESJJ\d0184889\070784-sht-striping.dgn	70784-sht-striping.dgn	DRAWN -	REVISED -
PLOT SCALE = 40.0000' / IN.		CHECKED -	REVISED -
PLOT DATE = 3/15/2010		DATE -	REVISED -

**STATE OF ILLINOIS
DEPARTMENT OF TRANSPORTATION**

STRIPING PLAN SHEET			
SCALE:	SHEET NO.	OF SHEETS	STA. TO STA.

F.A.P. RTE.	SECTION	COUNTY	TOTAL SHEETS	SHEET NO.
332	47RS-5	Vermilion	41	23
ILLINOIS FED. AID PROJECT			CONTRACT NO. 70784	

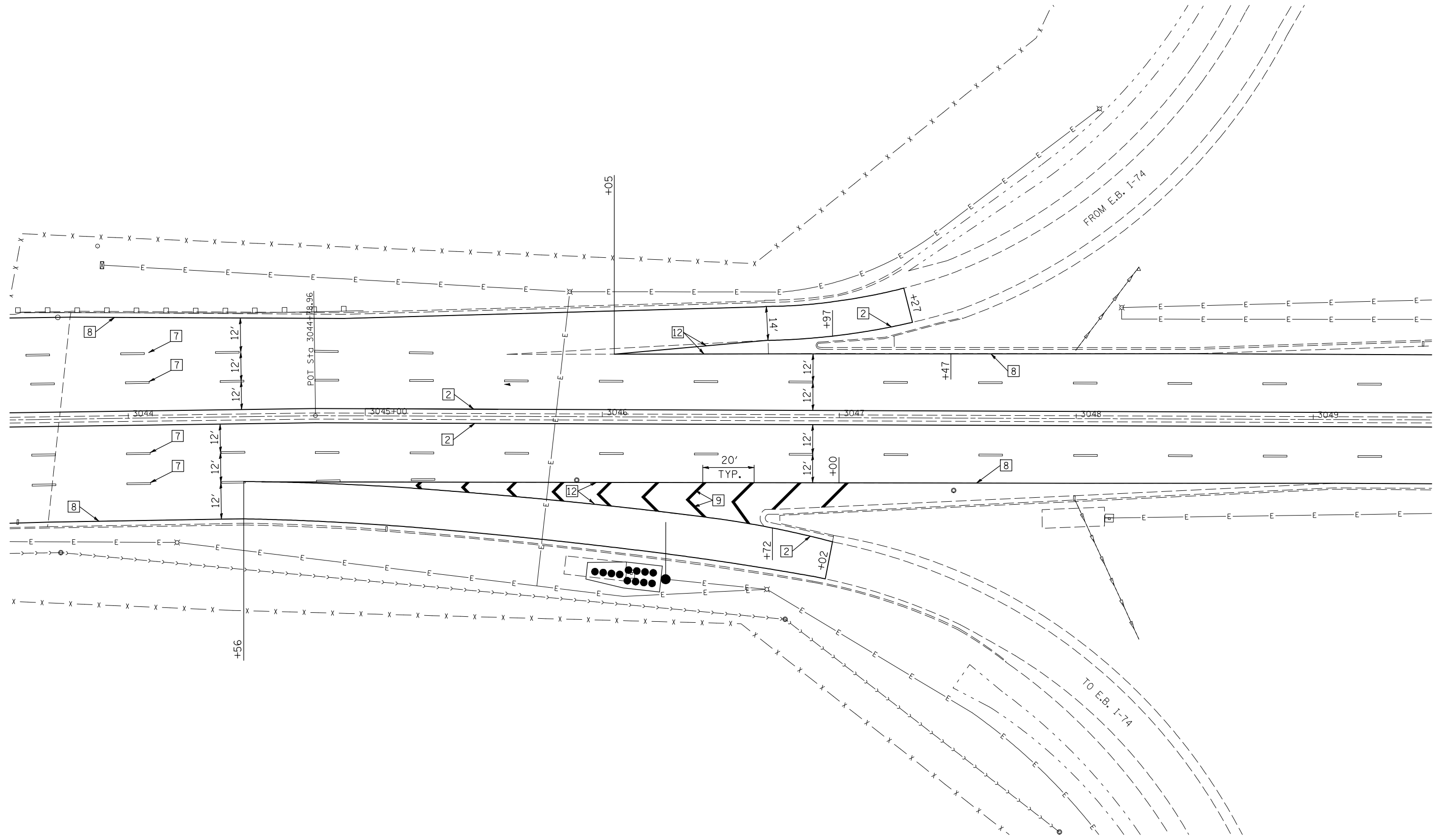
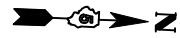

FILE NAME =	USER NAME = bucklesJJ	DESIGNED -	REVISED -
ct:\pw\work\PWIDOT\BUCKLESJJ\d0184889\070784-sht-striping.dgn		DRAWN -	REVISED -
	PLOT SCALE = 40.0000' / IN.	CHECKED -	REVISED -
	PLOT DATE = 3/15/2010	DATE -	REVISED -

**STATE OF ILLINOIS
DEPARTMENT OF TRANSPORTATION**

STRIPING PLAN SHEET			
SCALE:	SHEET NO.	OF SHEETS	STA. TO STA.

F.A.P. RTE.	SECTION	COUNTY	TOTAL SHEETS	SHEET NO.
332	47RS-5	Vermillion	41	24
CONTRACT NO. 70784			ILLINOIS FED. AID PROJECT	

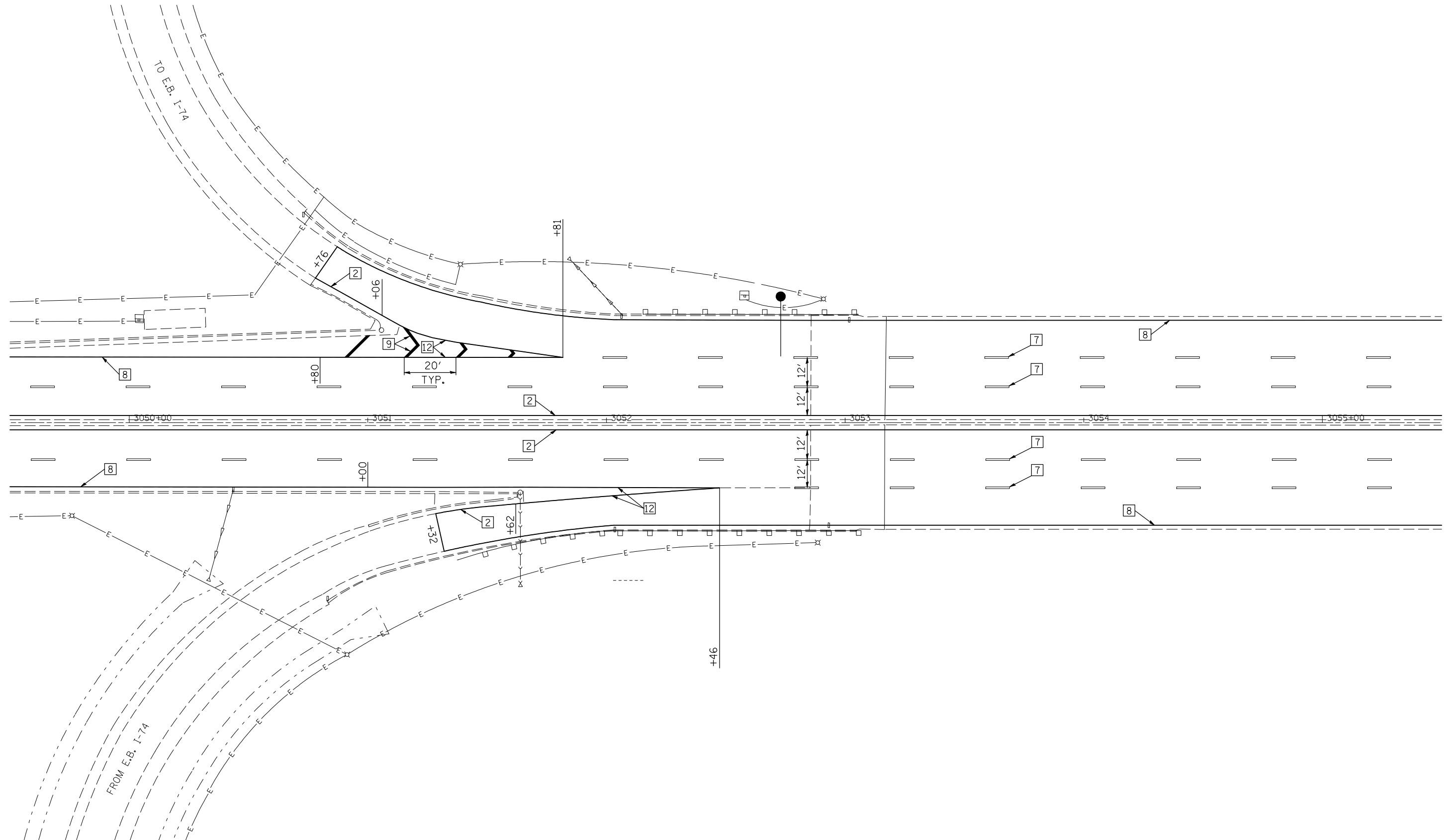
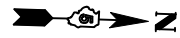

FILE NAME = c:\pwork\pwork\PWIDOT\BUCKLESJJ\d0184889\070784-sht-striping.dgn	USER NAME = bucklesjj	DESIGNED -	REVISED -	STATE OF ILLINOIS DEPARTMENT OF TRANSPORTATION	STRIPING PLAN SHEET			F.A.P. RTE.	SECTION	COUNTY	TOTAL SHEETS	SHEET NO.
	PLOT SCALE = 40.0000' / IN.	CHECKED -	REVISED -					332	47RS-5	Vermillion	41	25
PLOT DATE = 3/15/2010	DATE -	REVISED -	REVISED -		SCALE:	SHEET NO.	OF SHEETS	STA.	TO STA.	CONTRACT NO. 70784		
										ILLINOIS FED. AID PROJECT		

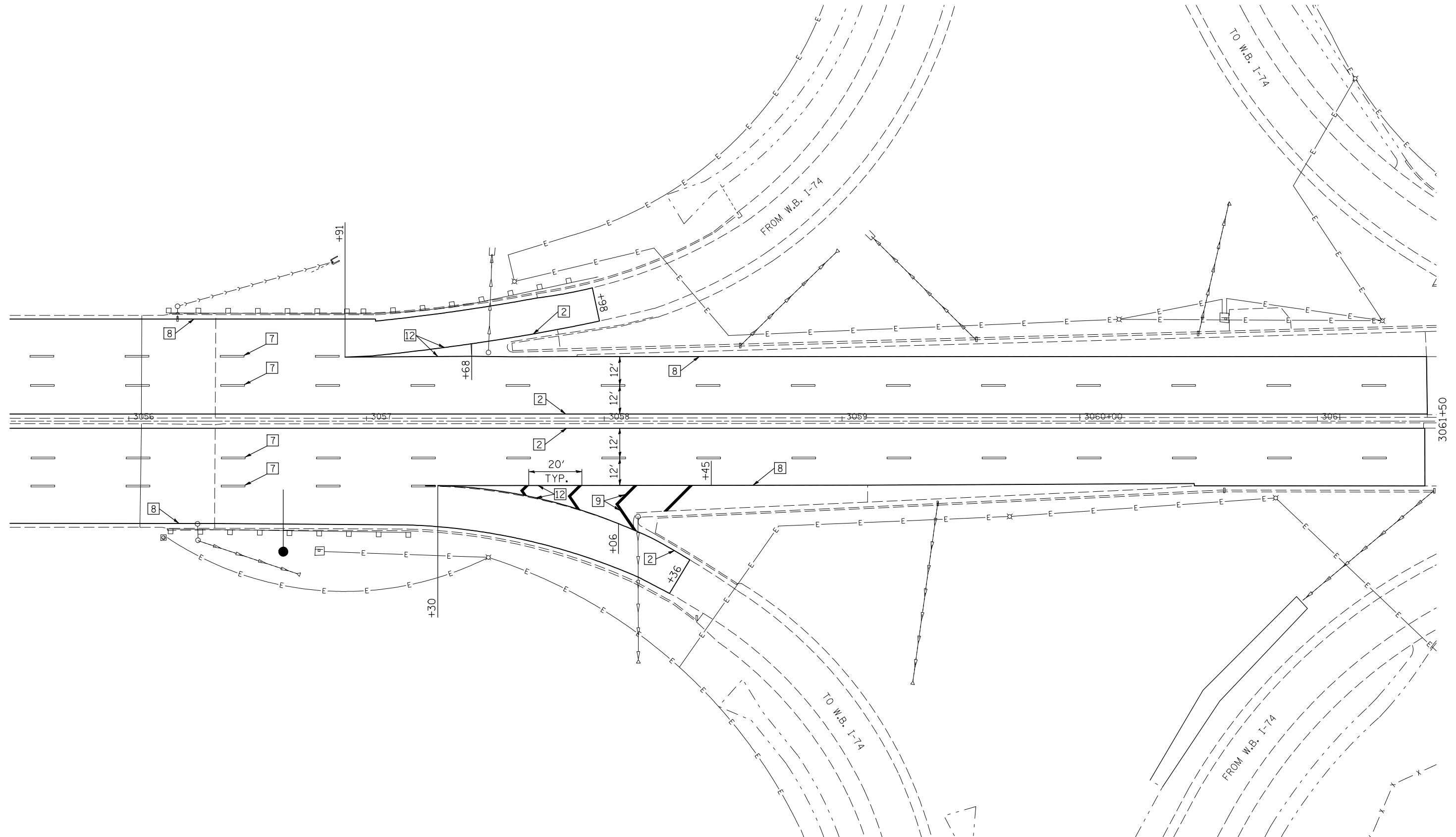

FILE NAME =	USER NAME = bucklesjj	DESIGNED -	REVISED -
ct:\pw\work\PWIDOT\BUCKLESJJ\d0184889\070784-sht-striping.dgn		DRAWN -	REVISED -
	PLOT SCALE = 40.0000' / IN.	CHECKED -	REVISED -
	PLOT DATE = 3/15/2010	DATE -	REVISED -

**STATE OF ILLINOIS
DEPARTMENT OF TRANSPORTATION**

STRIPING PLAN SHEET			
SCALE:	SHEET NO.	OF SHEETS	STA. TO STA.

F.A.P. RTE.	SECTION	COUNTY	TOTAL SHEETS	SHEET NO.
332	47RS-5	Vermillion	41	26
CONTRACT NO. 70784				
ILLINOIS FED. AID PROJECT				

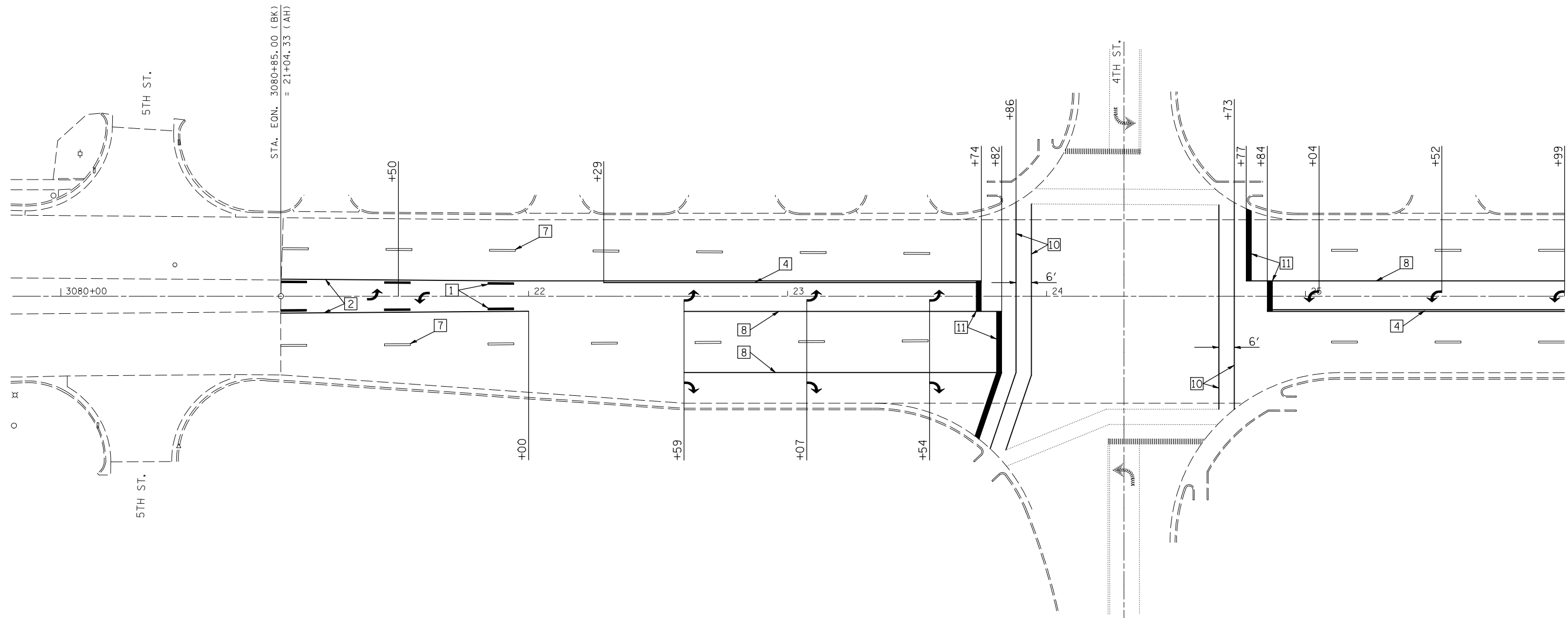

FILE NAME = c:\pw\work\PWIDOT\BUCKLESJJ\d0184889\070784-sht-striping.dgn	USER NAME = bucklesjj	DESIGNED -	REVISED -
		DRAWN -	REVISED -
	PLOT SCALE = 40.0000' / IN.	CHECKED -	REVISED -
	PLOT DATE = 3/15/2010	DATE -	REVISED -

**STATE OF ILLINOIS
DEPARTMENT OF TRANSPORTATION**

STRIPING PLAN SHEET

SCALE: SHEET NO. OF SHEETS STA. TO STA.

F.A.P. RTE. 332	SECTION 47RS-5	COUNTY Vermillion	TOTAL SHEETS 41	SHEET NO. 27
CONTRACT NO. 70784				ILLINOIS FED. AID PROJECT

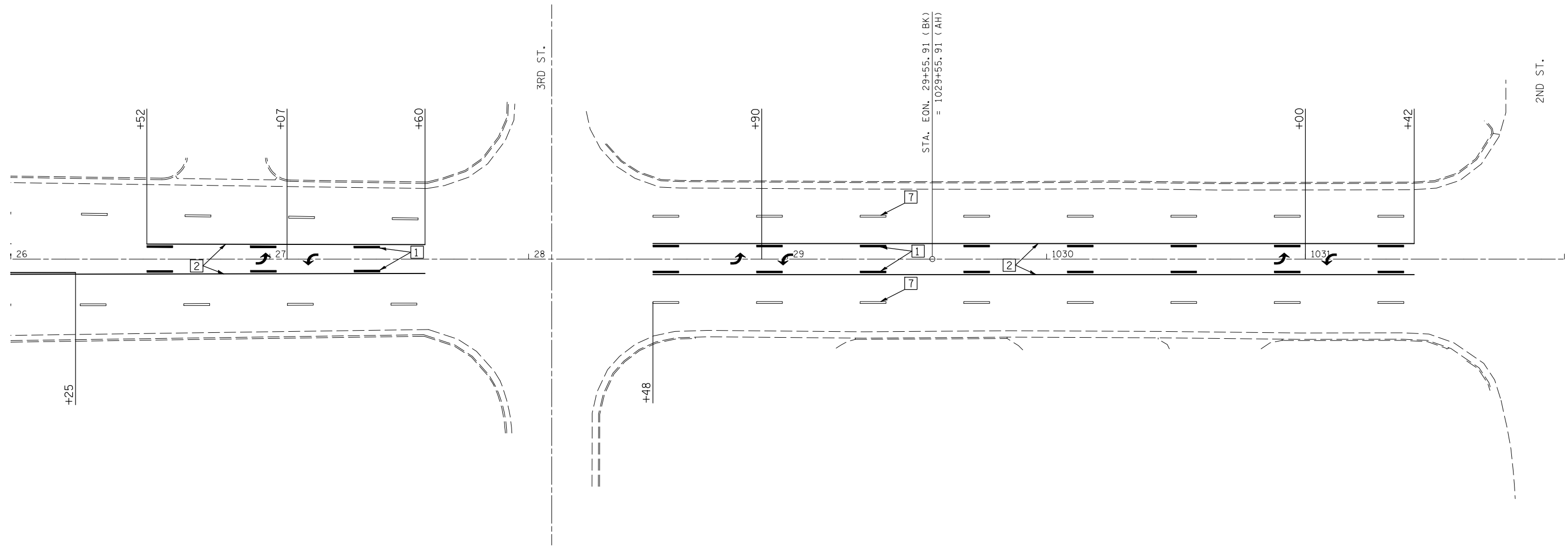

FILE NAME =	USER NAME = bucklesJJ	DESIGNED -	REVISED -
ct:\pw\work\PWIDOT\BUCKLESJJ\d0184889\070784-sht-striping.dgn		DRAWN -	REVISED -
	PLOT SCALE = 40.0000' / IN.	CHECKED -	REVISED -
	PLOT DATE = 3/15/2010	DATE -	REVISED -

**STATE OF ILLINOIS
DEPARTMENT OF TRANSPORTATION**

STRIPING PLAN SHEET			
SCALE:	SHEET NO.	OF SHEETS	STA. TO STA.

F.A.P. RTE.	SECTION	COUNTY	TOTAL SHEETS	SHEET NO.
332	47RS-5	Vermillion	41	28
ILLINOIS FED. AID PROJECT			CONTRACT NO. 70784	

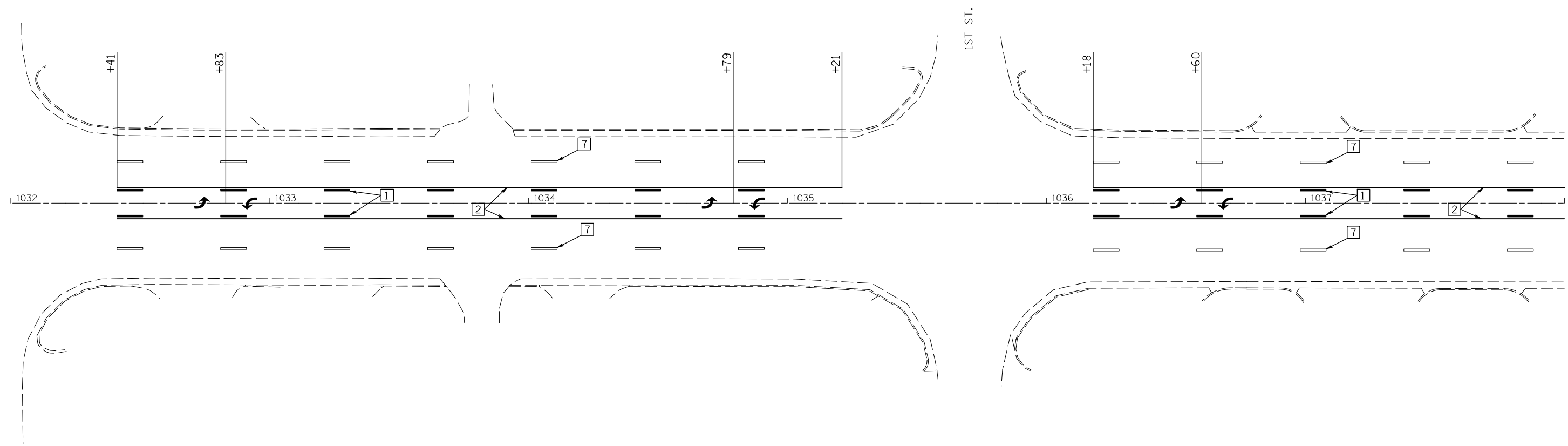

FILE NAME =	USER NAME = bucklesJJ	DESIGNED -	REVISED -
ct\pw\work\PWIDOT\BUCKLESJJ\d0184889\070784-sht-striping.dgn		DRAWN -	REVISED -
	PLOT SCALE = 40.0000' / IN.	CHECKED -	REVISED -
	PLOT DATE = 3/15/2010	DATE -	REVISED -

**STATE OF ILLINOIS
DEPARTMENT OF TRANSPORTATION**

STRIPING PLAN SHEET

SCALE: SHEET NO. OF SHEETS STA. TO STA.

F.A.P. RTE.	SECTION	COUNTY	TOTAL SHEETS	SHEET NO.
332	47RS-5	Vermillion	41	29
ILLINOIS FED. AID PROJECT			CONTRACT NO. 70784	

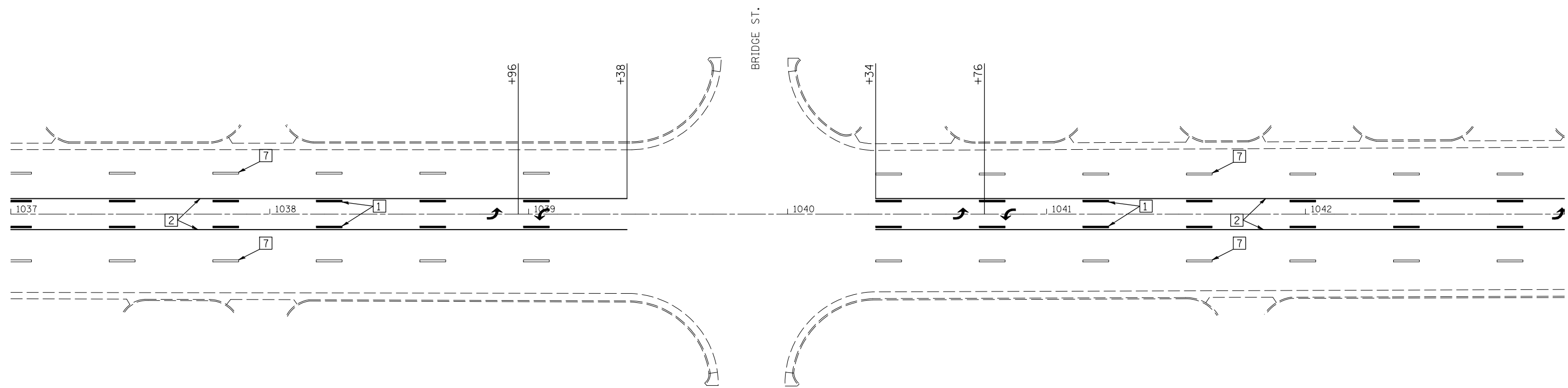

FILE NAME =	USER NAME = bucklesjj	DESIGNED -	REVISED -
ct:\pw\work\PWIDOT\BUCKLESJJ\d0184889\070784-sht-striping.dgn		DRAWN -	REVISED -
	PLOT SCALE = 40.0000' / IN.	CHECKED -	REVISED -
	PLOT DATE = 3/15/2010	DATE -	REVISED -

**STATE OF ILLINOIS
DEPARTMENT OF TRANSPORTATION**

STRIPING PLAN SHEET

SCALE: SHEET NO. OF SHEETS STA. TO STA.

F.A.P. RTE.	SECTION	COUNTY	TOTAL SHEETS	SHEET NO.
332	47RS-5	Vermillion	41	30
ILLINOIS FED. AID PROJECT			CONTRACT NO. 70784	

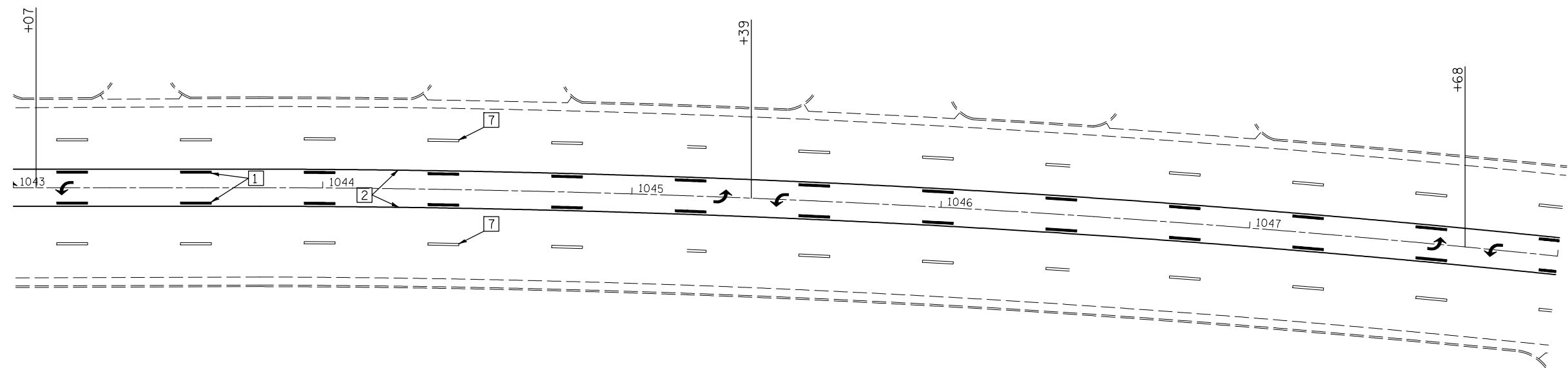

FILE NAME =	USER NAME = bucklesJJ	DESIGNED -	REVISED -
ct\pwork\pwork\DOT\BUCKLESJJ\d0184889\070784-sht-striping.dgn		DRAWN -	REVISED -
		CHECKED -	REVISED -
		DATE -	REVISED -

**STATE OF ILLINOIS
DEPARTMENT OF TRANSPORTATION**

STRIPING PLAN SHEET			
SCALE:	SHEET NO.	OF SHEETS	STA. TO STA.

F.A.P. RTE.	SECTION	COUNTY	TOTAL SHEETS	SHEET NO.
332	47RS-5	Vermilion	41	31
CONTRACT NO. 70784			ILLINOIS FED. AID PROJECT	

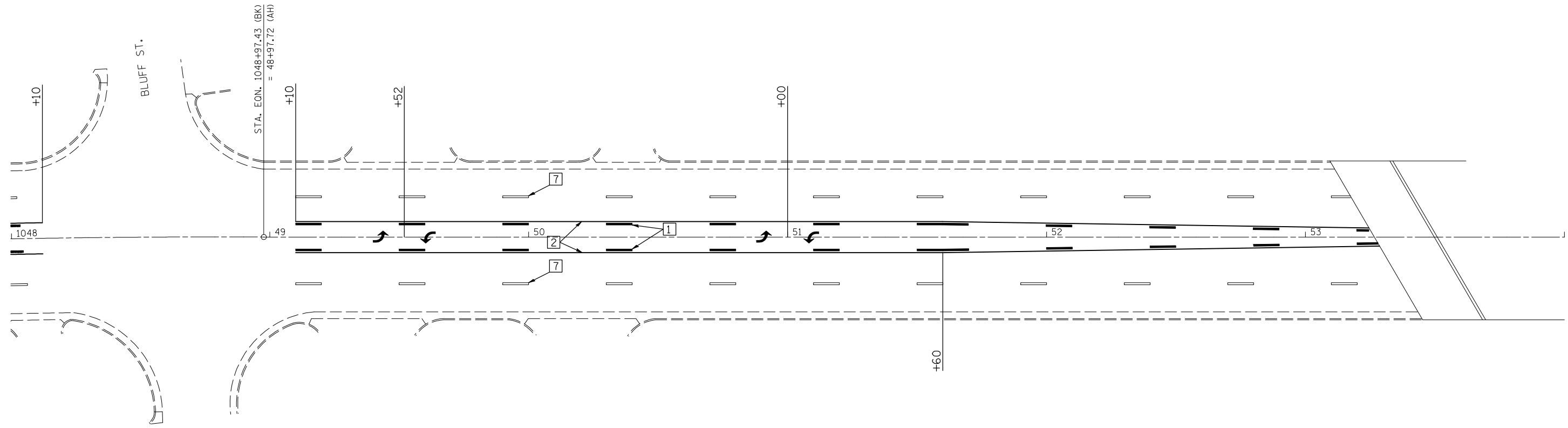

FILE NAME =	USER NAME = bucklesJJ	DESIGNED -	REVISED -
ct:\pw\work\PWIDOT\BUCKLESJJ\d0184889\070784-sht-striping.dgn		DRAWN -	REVISED -
	PLOT SCALE = 40.0000' / IN.	CHECKED -	REVISED -
	PLOT DATE = 3/15/2010	DATE -	REVISED -

**STATE OF ILLINOIS
DEPARTMENT OF TRANSPORTATION**

STRIPING PLAN SHEET

SCALE: SHEET NO. OF SHEETS STA. TO STA.

F.A.P. RTE.	SECTION	COUNTY	TOTAL SHEETS	SHEET NO.
332	47RS-5	Vermillion	41	32
ILLINOIS FED. AID PROJECT			CONTRACT NO. 70784	

TYPICAL DETAIL OF SIDEROAD RETURNS

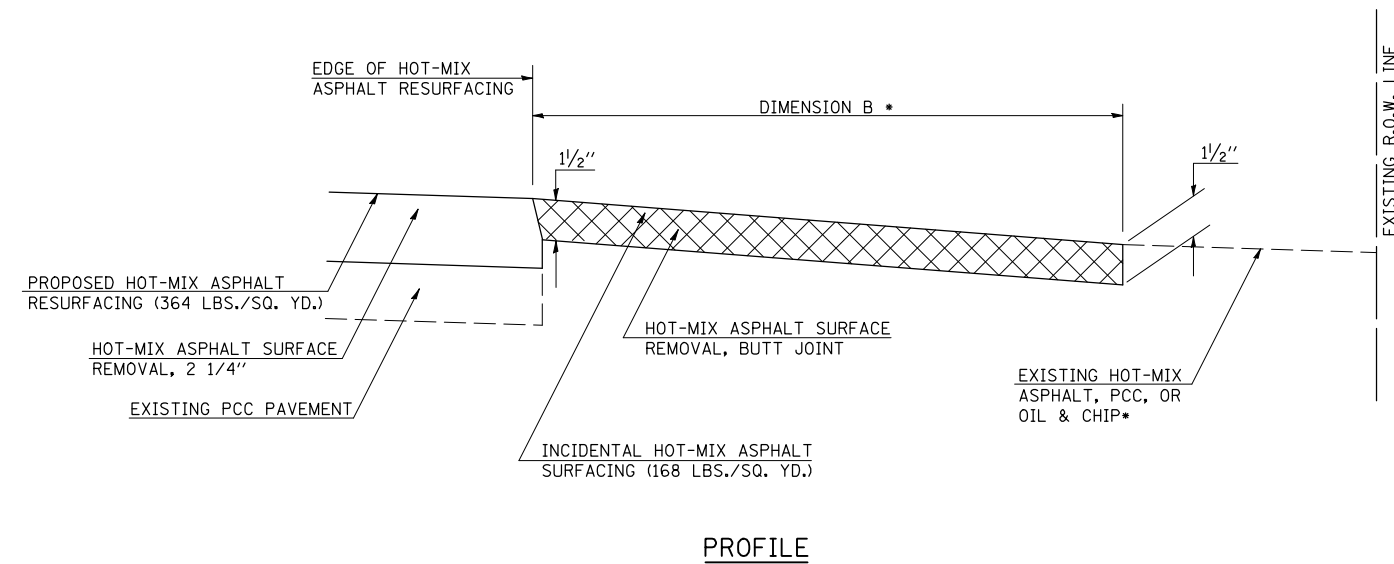
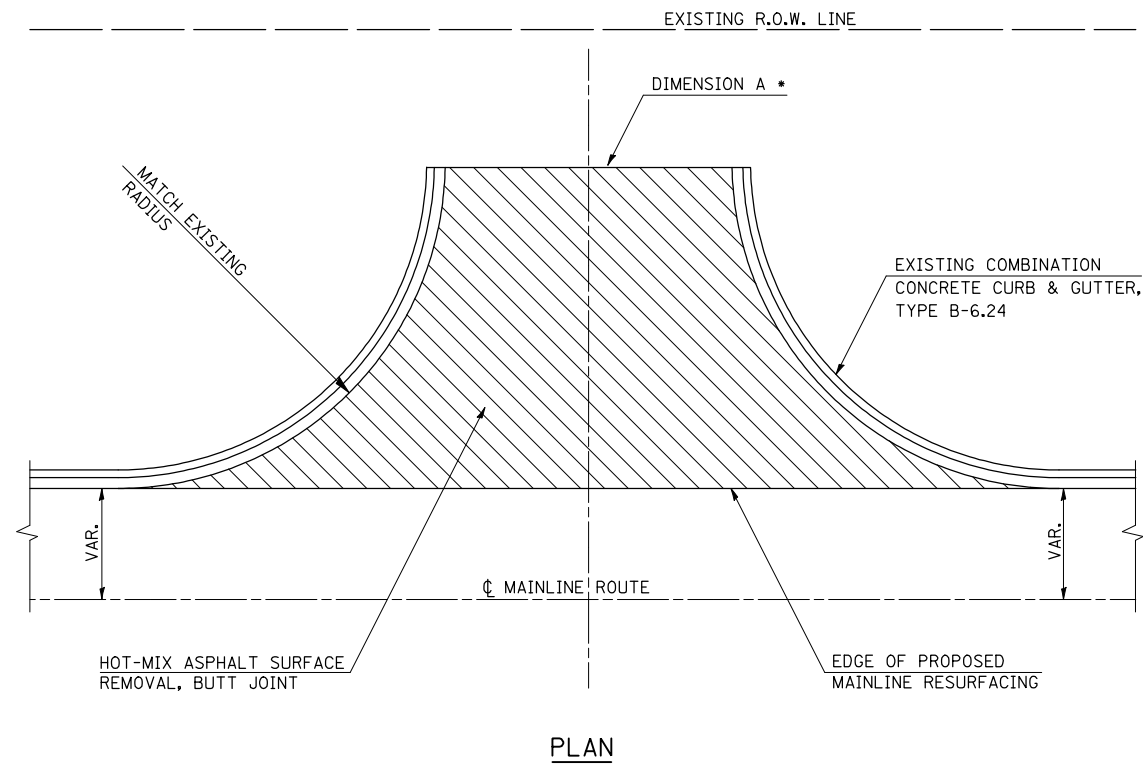

GENERAL NOTES

1. THE EXISTING SURFACE SHALL BE PREPARED IN ACCORDANCE WITH SECTION 408 OF THE STANDARD SPECIFICATIONS.
2. THE INCIDENTAL HOT-MIX ASPHALT SURFACING IS INTENDED TO RESURFACE THE EXISTING SIDEROADS IN THEIR ENTIRETY. THE EXISTING SIDEROADS SHOULD BE RESURFACED TO MAINTAIN THEIR CURRENT RADII.

* SIDEROAD DIMENSIONS

SIDEROAD NAME	STATION	LT OR RT	DIMA*	DIM B*
E 16TH ST	3029+26.55	RT	31.9'	10.0'
W 16TH ST	3029+28.95	LT	25.7'	29.9'
W 3RD ST	28+08.08	LT	27.2'	35.0'
E 3RD ST	28+08.89	RT	31.9'	35.0'
W 2ND ST	1031+91.45	LT	26.4'	35.0'
E 2ND ST	1031+89.14	RT	28.0'	35.0'
W 1ST ST	1035+71.27	LT	26.0'	35.0'
E 1ST ST	1035+70.25	RT	26.0'	35.0'
W BRIDGE ST	1039+86.84	LT	26.0'	35.0'
E BRIDGE ST	1039+06.67	RT	26.0'	35.0'
W BLUFF ST	1048+61.69	LT	29.0'	40.0'
E BLUFF ST	1048+61.69	RT	26.0'	40.0'

FILE NAME =	USER NAME = bucklesjj	DESIGNED - BJH	REVISED -
ct:\pw\work\PWIDOT\BUCKLESJJ\d0184908\070784-sht-Details.dgn		DRAWN - 9/29/2009	REVISED -
	PLOT SCALE = 40.0000' / IN.	CHECKED -	REVISED -
	PLOT DATE = 3/15/2010	DATE -	REVISED -

STATE OF ILLINOIS
DEPARTMENT OF TRANSPORTATION

SIDEROAD RESURFACING DETAILS

SCALE: SHEET NO. OF SHEETS STA. TO STA.

F.A.P. RTE.	SECTION	COUNTY	TOTAL SHEETS	SHEET NO.
332	47RS-5	VERMILION	41	33
CONTRACT NO. 70784				
ILLINOIS FED. AID PROJECT				

**APPLICATION NO. 1
DAY OPERATION ONLY
PARTIAL RAMP CLOSURE**

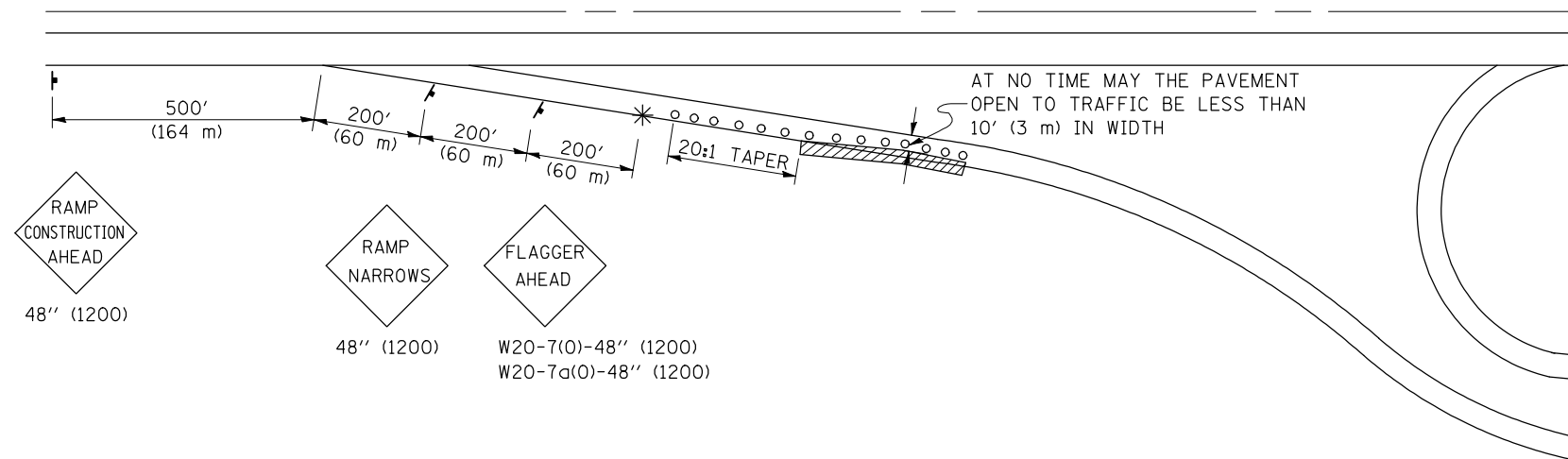

SYMBOLS

- (APPLICATION NO. 1) TYPE I OR II BARRICADES OR DRUMS @ 50' (15 m) CTS.
- ⊗ (APPLICATION NO. 2) TYPE I OR II BARRICADES OR DRUMS @ 25' (7.5 m) CTS. W/STEADY BURNING LIGHTS
- * (APPLICATION NO. 1) FLAGGER PLACED AS DIRECTED BY THE ENGINEER
- † SIGN ON PORTABLE OR PERMANENT SUPPORT
- ▨ WORK AREA

TYPICAL APPLICATIONS

HMA SURFACE COURSE.

GENERAL NOTES

CONSTRUCTION OPERATIONS SHALL BE CONFINED TO AN AREA NARROW ENOUGH THAT A MINIMUM OF 10' (3 m) OF PAVEMENT SHALL BE OPEN TO TRAFFIC AT ALL TIMES.

FULL WIDTH PAVEMENT ON THE RAMPS SHALL BE OPEN TO TRAFFIC AT NIGHT.

WHEN NO WORK IS BEING PERFORMED, THE FLAGGER WILL NOT BE REQUIRED. IF THE FLAGGER IS NOT PRESENT, THE FLAGGER SIGNS SHALL BE REMOVED OR COVERED.

ALL SIGNS SHALL BE POST MOUNTED IF WORK IN THE AREA EXCEEDS FOUR DAYS OF DAYTIME OPERATIONS.

LONGITUDINAL DIMENSIONS MAY BE ADJUSTED SLIGHTLY TO FIT FIELD CONDITIONS.

ALL VEHICLES, EQUIPMENT, WORKERS (EXCEPT FLAGGER) AND THEIR ACTIVITIES ARE RESTRICTED AT ALL TIMES TO ONE SIDE OF THE PAVEMENT UNLESS OTHERWISE AUTHORIZED BY THE DISTRICT ENGINEER.

Traffic Control for all ramps shall be in accordance with the appropriate application of plan detail TRAFFIC CONTROL FOR RAMPS and will not be paid for separately, but shall be included in the contract lump sum prices for Traffic Control and Protection, Standard 701602 and Traffic Control and Protection, Standard 701606.

**APPLICATION NO. 2
RAMP CLOSURE**

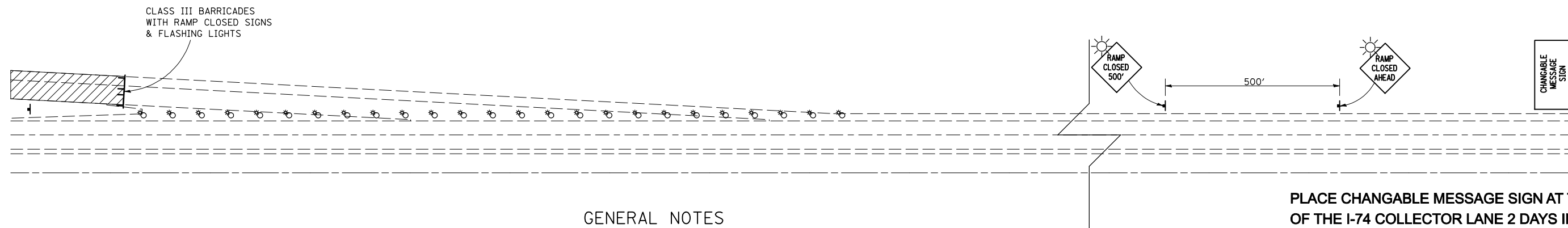

GENERAL NOTES

STEADY BURN LIGHTS ARE NOT REQUIRED FOR DAYTIME OPERATIONS.

CONTACT THE DISTRICT TRAFFIC OPERATIONS ENGINEER AT 217-465-4181, ONE WEEK PRIOR TO CLOSING THE RAMP.

PLACE CHANGABLE MESSAGE SIGN AT THE BEGINNING OF THE I-74 COLLECTOR LANE 2 DAYS IN ADVANCED OF PAVING THE RAMPS.

Note: All dimensions are in INCHES (millimeters) unless otherwise shown.

FILE NAME =	USER NAME = bucklesJJ	DESIGNED -	REVISED - 11/06
ct:\pw\work\pwidot\BUCKLESJJ\d0184908\0570784-sht-Details.dgn		DRAWN -	REVISED -
	PLOT SCALE = 40.0000' / IN.	CHECKED -	REVISED -
	PLOT DATE = 3/15/2010	DATE -	REVISED -

**STATE OF ILLINOIS
DEPARTMENT OF TRANSPORTATION**

TRAFFIC CONTROL FOR RAMPS

SCALE: SHEET NO. OF SHEETS STA. TO STA.

DISTRICT 5 DETAIL NO. 70103710

F.A.P. RTE.	SECTION	COUNTY	TOTAL SHEETS	SHEET NO.
332	4TRS-5	VERMILION	41	34
FED. ROAD DIST. NO. ILLINOIS FED. AID PROJECT			CONTRACT NO. 70784	

ROAD CLOSURE

SIDEROAD / STREET CLOSURE

SYMBOLS	
	TYPE III BARRICADE (SEE NOTE 1)
	FLASHING AMBER LIGHT (TYPE A)

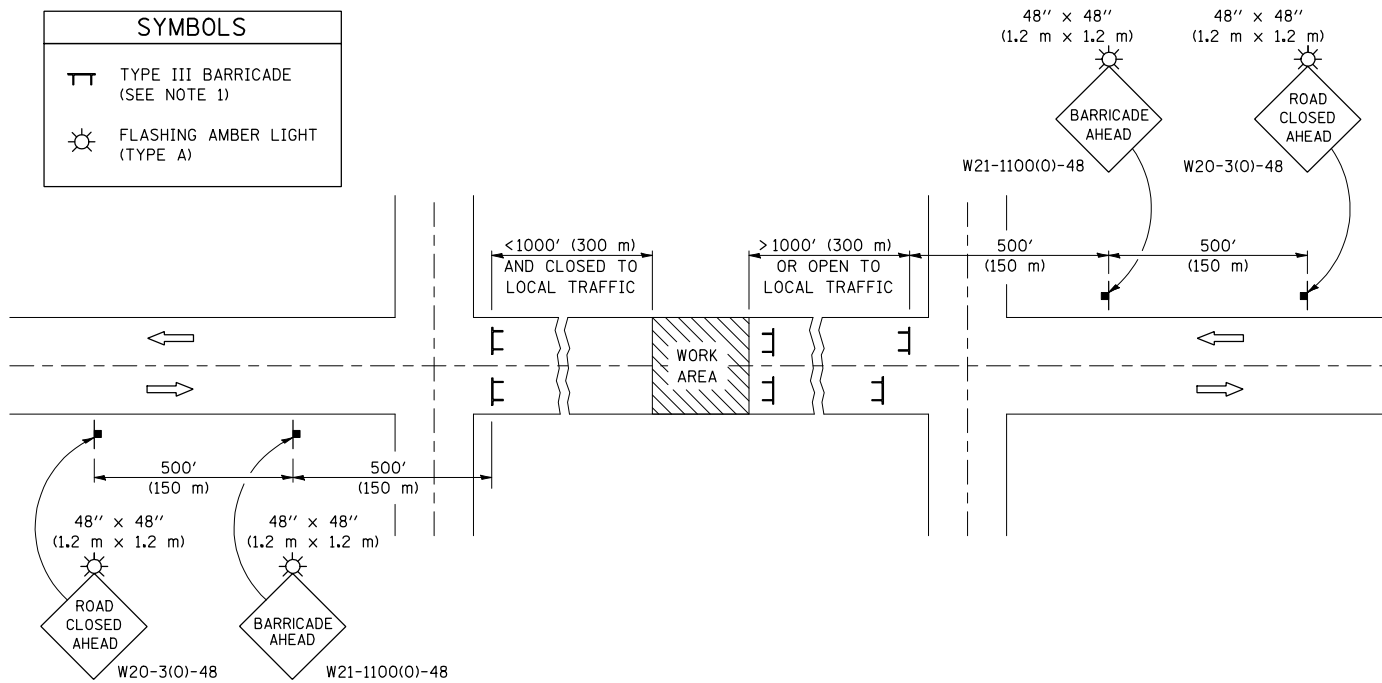

GENERAL NOTES

- TYPE III BARRICADES SHALL BE AS SHOWN ON STANDARD 701901 "TYPICAL APPLICATIONS OF TYPE III BARRICADES CLOSING A ROAD". EACH TYPE III BARRICADE SHALL HAVE TWO FLASHING AMBER LIGHTS MOUNTED ABOVE IT.
- IF THE ROAD IS OPEN TO LOCAL TRAFFIC OR EXCEEDS 1000' (300 m), ANOTHER SET OF TYPE III BARRICADES, EQUIPPED AS IN NOTE 1 ABOVE, SHALL BE PLACED AT EACH END OF THE WORK AREA.
- WHEN A STOP CONDITION EXISTS, NO SIGNS ARE REQUIRED IN ADVANCE OF THE "STOP" SIGN WHEN THE ROAD IS CLOSED WITHIN 100' (30 m) OF THE INTERSECTION.
- STANDARD 701901 SHALL APPLY FOR THE PLACEMENT & DESIGN OF TYPE III BARRICADES.
- IF A TYPE III BARRICADE WITH AN ATTACHED SIGN PANEL WHICH MEETS NCHRP 350 IS NOT AVAILABLE, THE SIGNS MAY BE MOUNTED ON AN NCHRP 350 TEMPORARY SIGN SUPPORT DIRECTLY IN FRONT OF THE BARRICADE.
- REFLECTORIZED STRIPING SHALL APPEAR ON BOTH SIDES OF THE TY III BARRICADES IF ROAD IS OPEN TO LOCAL TRAFFIC.
- ALL SIGNS SHALL BE POST MOUNTED IF THE CLOSURE TIME EXCEEDS FOUR DAYS.
- A MINIMUM OF TWO FLASHING LIGHTS SHALL BE USED AT NIGHT ON EACH APPROACH IN ADVANCE OF THE WORK AREA. FLASHING LIGHTS SHALL BE INSTALLED ABOVE THE FIRST TWO SIGNS IN THE SERIES.
- LONGITUDINAL DIMENSIONS MAY BE ADJUSTED SLIGHTLY TO FIT FIELD CONDITIONS.
- FORMS BT. 725 AND BT. 726 ARE REQUIRED.
- WHEN A SIDEROAD INTERSECTS THE HIGHWAY ON WHICH WORK IS BEING PERFORMED, ADDITIONAL TRAFFIC DEVICES SHALL BE ERECTED AND PROVIDED AS DIRECTED BY THE ENGINEER.
- AN ADDITIONAL SIGN MAY BE REQUIRED AT A MAJOR INTERSECTING ROAD IN ADVANCE OF THE CLOSURE. THE ADDITIONAL SIGN SHALL GIVE THE DISTANCE TO THE BARRICADE IN MILES OR FRACTIONS OF A MILE.

SYMBOLS	
	TYPE III BARRICADE (SEE NOTE)
	FLASHING LIGHT
	FLAGGER WITH TRAFFIC CONTROL SIGN (WHILE WORK IS BEING PERFORMED)
	CONE (DAYLIGHT HOURS ONLY), DRUM, TYPE I OR TYPE II BARRICADE
	WORK AREA
	TRAFFIC FLOW

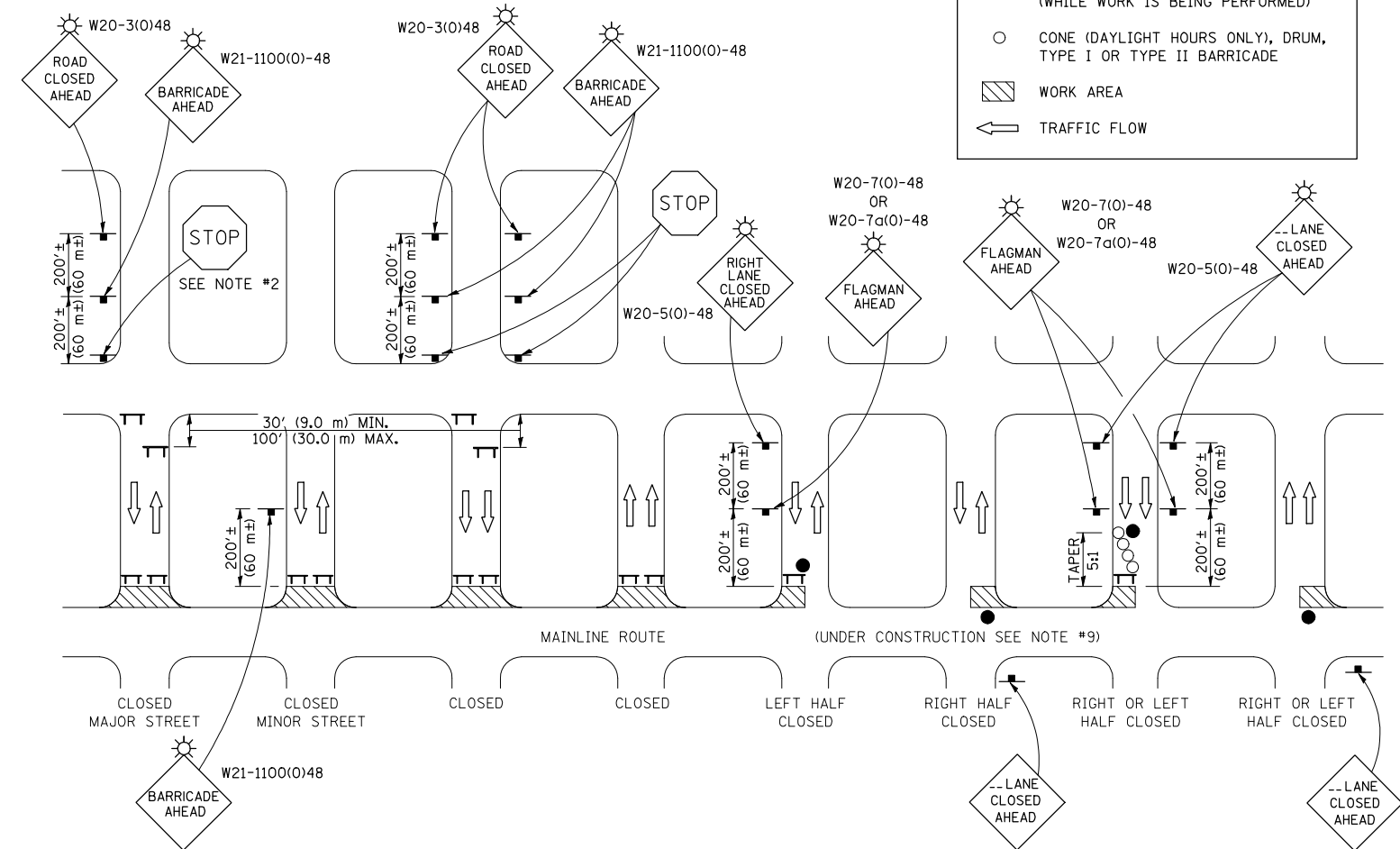

GENERAL NOTES

- TYPE III BARRICADES SHALL BE AS SHOWN ON "TYPICAL APPLICATIONS OF TYPE III BARRICADES CLOSING A ROAD". EACH TYPE III BARRICADE SHALL HAVE TWO FLASHING AMBER LIGHTS MOUNTED ABOVE IT.
- WHERE A STOP CONDITION EXISTS, AS SHOWN ABOVE, WARNING SIGNS MAY BE OMITTED IN ADVANCE OF THE "STOP" SIGN.
- STANDARD 701901 SHALL APPLY FOR THE PLACEMENT & MANUFACTURE OF TYPE III BARRICADES.
- ALL SIGNS SHALL BE POST MOUNTED IF THE CLOSURE TIME EXCEEDS FOUR DAYS.
- ONE FLASHING LIGHT IS REQUIRED ABOVE EACH ADVANCE WARNING SIGN DURING HOURS OF DARKNESS.
- LONGITUDINAL DIMENSIONS MAY BE ADJUSTED SLIGHTLY TO FIT FIELD CONDITIONS.
- FORMS BT 725 AND BT 726 ARE REQUIRED.
- THE MAINLINE ROUTE TEMPORARY TRAFFIC CONTROL SHALL BE IN ACCORDANCE WITH THE PLANS, SPECIAL PROVISIONS AND STANDARD SPECIFICATIONS.
- ALL FLAGGERS REQUIRED AT SIDE ROADS AND ENTRANCES REMAINING OPEN TO TRAFFIC AND/OR ADDITIONAL BARRICADES REQUIRED BY THE ENGINEER TO CLOSE SIDE ROADS AND ENTRANCES WILL BE PAID FOR ACCORDING TO ARTICLE 109.04.

Note: All dimensions are in INCHES (millimeters) unless otherwise shown.

FILE NAME =	USER NAME = bucklesjj	DESIGNED -	REVISED - 11/06
et:\pw\work\PWIDOT\BUCKLESJJ\d0184908.DWG	70784-sht-Details.dgn	DRAWN -	REVISED - 12/07
	PLOT SCALE = 40.0000 ' / IN.	CHECKED -	REVISED - 09/09 - KJT
	PLOT DATE = 3/15/2010	DATE -	REVISED -

STATE OF ILLINOIS
DEPARTMENT OF TRANSPORTATION

TRAFFIC CONTROL & PROTECTION DEVICES
(ROAD & SIDEROAD/STREET CLOSURES)

SCALE: SHEET NO. OF SHEETS STA. TO STA.

DISTRICT 5 DETAIL NO. 7020000

F.A.P. RTE.	SECTION	COUNTY	TOTAL SHEETS	SHEET NO.
332	4TRS-5	VERMILION	41	35
CONTRACT NO. 70784				
FED. ROAD DIST. NO. ILLINOIS FED. AID PROJECT				

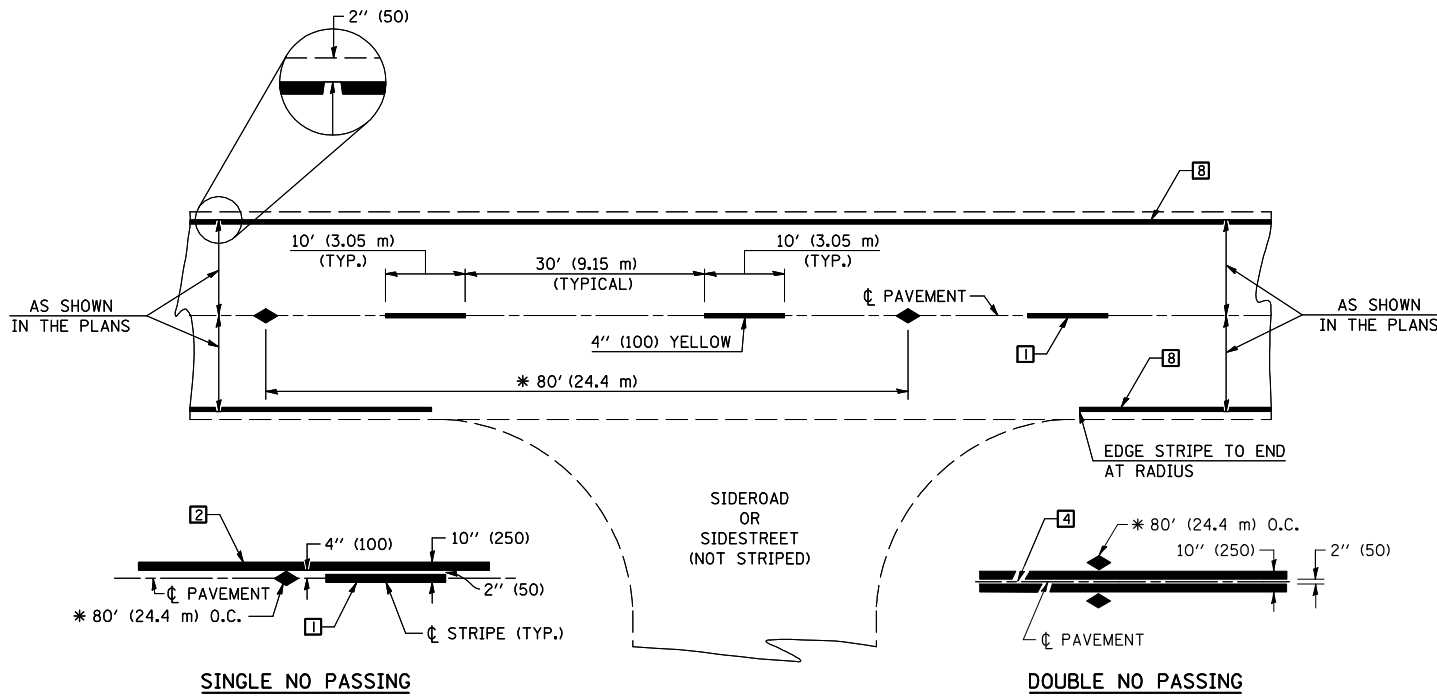

* REDUCE TO 40' (12.2 m) O.C. ON CURVES WITH POSTED OR ADVISORY SPEEDS OF 45 mph (70 km/h) OR LESS.

TWO LANE/TWO WAY

TYPICAL PAVEMENT MARKING LEGEND

- 1 4" (100) SKIP-DASH (YELLOW)
- 2 4" (100) SOLID (YELLOW)
- 3 12" (300) DIAGONAL (YELLOW)
- 4 4" (100) DOUBLE YELLOW (NARROW)
- 5 RESERVED
- 6 RESERVED
- 7 4" (100) SKIP-DASH (WHITE)
- 8 4" (100) SOLID (WHITE)
- 9 12" (300) DIAGONAL (WHITE)
- 10 6" (150) SOLID (WHITE)
- 11 24" (600) STOP BAR (WHITE)
- 12 8" (200) SOLID (WHITE)
- 13 4" (100) LANE LINE EXTENSIONS (WHITE)
- 14 4" (100) PARKING WHITE

TYPICAL PAVEMENT MARKERS LEGEND

- ◆ TWO-WAY AMBER MARKER
- ▶ ONE-WAY AMBER MARKER
- ▷ ONE-WAY CRYSTAL MARKER

RURAL LEFT TURN

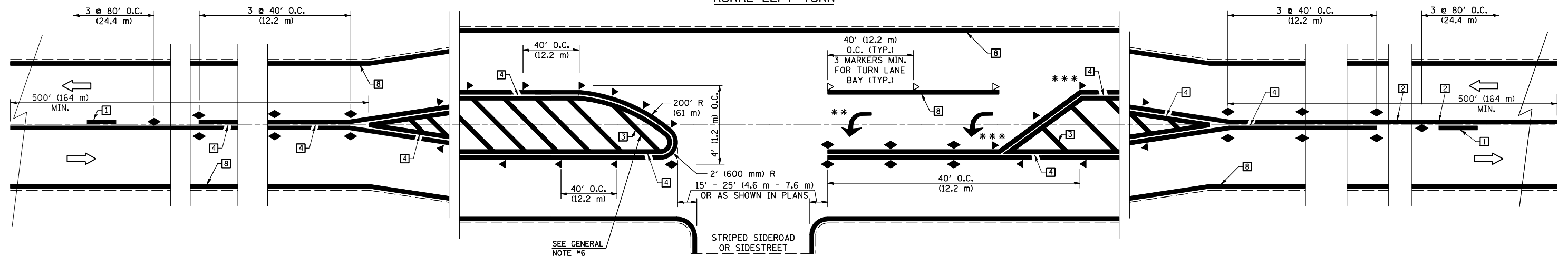

*** REDUCE SPACING IF NECESSARY TO ASSURE MARKERS AT CORNER POINTS.

** TURN ARROWS SHALL BE PLACED AS SHOWN ON SHEET #2.

Note: All dimensions are in INCHES (millimeters) unless otherwise shown.

DISTRICT 5 DETAIL NO. 7800AAA

FILE NAME =	USER NAME = bucklesJJ	DESIGNED -	REVISED - 11/06
ct:\pw\work\PWIDOT\BUCKLESJJ\d0184908.D	70784-sht-Details.dgn	DRAWN -	REVISED - 09/2009 - KJT
	PLOT SCALE = 40.0000' / IN.	CHECKED -	REVISED -
	PLOT DATE = 3/15/2010	DATE -	REVISED -

**STATE OF ILLINOIS
DEPARTMENT OF TRANSPORTATION**

**PAVEMENT MARKING AND MARKERS
(RURAL & URBAN APPLICATIONS)**

SCALE: SHEET NO. 1 OF 4 SHEETS STA. TO STA.

F.A.P. RTE.	SECTION	COUNTY	TOTAL SHEETS	SHEET NO.
332	4TRS-5	VERMILION	41	36
CONTRACT NO. 70784				
FED. ROAD DIST. NO. ILLINOIS FED. AID PROJECT				

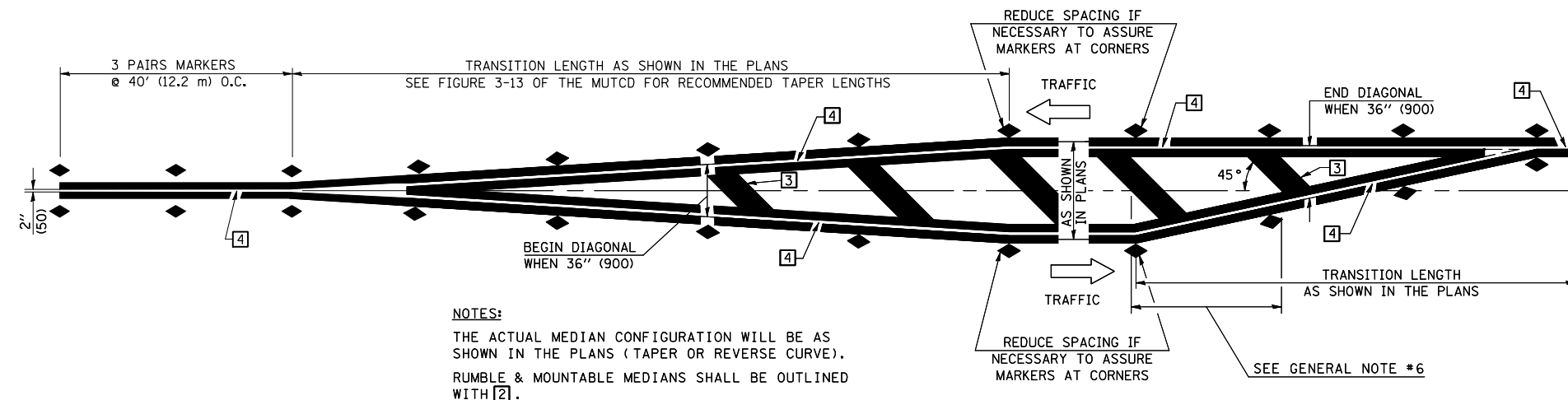

NOTES:
 THE ACTUAL MEDIAN CONFIGURATION WILL BE AS SHOWN IN THE PLANS (TAPER OR REVERSE CURVE).
 RUMBLE & MOUNTABLE MEDIANS SHALL BE OUTLINED WITH [2].

TYPICAL MEDIAN TRANSITIONS

GENERAL NOTES

1. WHEN MEDIANS ARE PRESENT, PAVEMENT MARKINGS ARE TO BE PLACED ADJACENT TO MEDIANS.
2. SOME OF THE INFORMATION INCLUDED WITH THIS DETAIL MAY NOT BE APPLICABLE TO THIS IMPROVEMENT.
3. PAVEMENT MARKINGS ARE TO BE EXTENDED THROUGH OMISSIONS WHEN APPLICABLE.
4. A STRIPING KEY IS AVAILABLE ELSEWHERE AND SHALL BE SHOWN WHERE THE QUANTITIES ARE LISTED.
5. FINAL PAVEMENT MARKINGS SHALL BE IN PLACE PRIOR TO PLACING ANY RAISED REFLECTIVE PAVEMENT MARKERS.
6. THE FOLLOWING CRITERIA SHALL BE USED FOR SELECTING THE DIAGONAL PAVEMENT MARKING SPACING,
 < 30 MPH USE 15' (< 50 km/h USE 4.5 m)
 30-45 MPH USE 20' (50-75 km/h USE 6.0 m)
 > 45 MPH USE 30' (> 75 km/h USE 9.0 m)

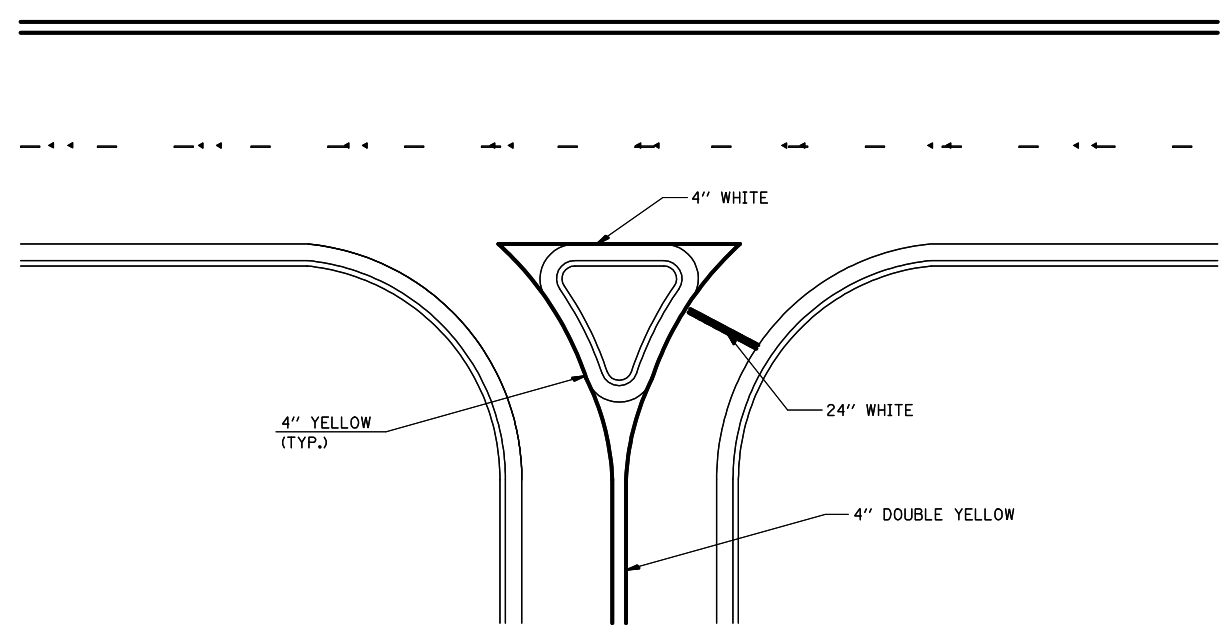

RIGHT IN - RIGHT OUT ACCESS

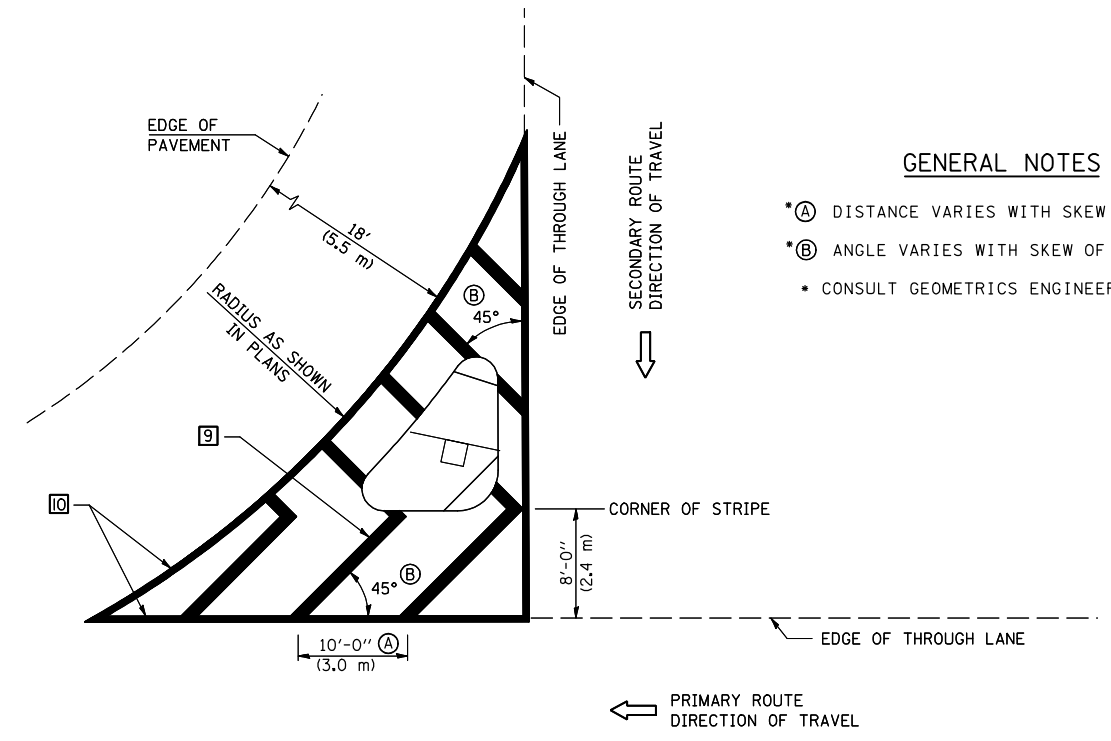

GENERAL NOTES

- *A DISTANCE VARIES WITH SKEW OF INTERSECTION.
- *B ANGLE VARIES WITH SKEW OF INTERSECTION.
- CONSULT GEOMETRICS ENGINEER

ISLAND

Note: All dimensions are in INCHES (millimeters) unless otherwise shown.

FILE NAME =	USER NAME = bucklesjj	DESIGNED -	REVISED - 11/06
ct:\pwwork\pwwid\BUCKLESJJ\d0184908.D	70784-sht-Details.dgn	DRAWN -	REVISED - 09/2009 - KJT
	PLOT SCALE = 40.0000' / IN.	CHECKED -	REVISED -
	PLOT DATE = 3/15/2010	DATE -	REVISED -

**STATE OF ILLINOIS
 DEPARTMENT OF TRANSPORTATION**

**PAVEMENT MARKING AND MARKERS
 (RURAL & URBAN APPLICATIONS)**

SCALE: SHEET NO. 3 OF 4 SHEETS STA. TO STA.

DISTRICT 5 DETAIL NO. 7800AAA

F.A.P. RTE.	SECTION	COUNTY	TOTAL SHEETS	SHEET NO.
332	47RS-5	VERMILION	41	37
CONTRACT NO. 70784				
FED. ROAD DIST. NO. ILLINOIS FED. AID PROJECT				

RAILROAD CROSSING WITH INTERCONNECT ONLY

RAILROAD CROSSING WITH INTERCONNECT AND PRE-SIGNALS

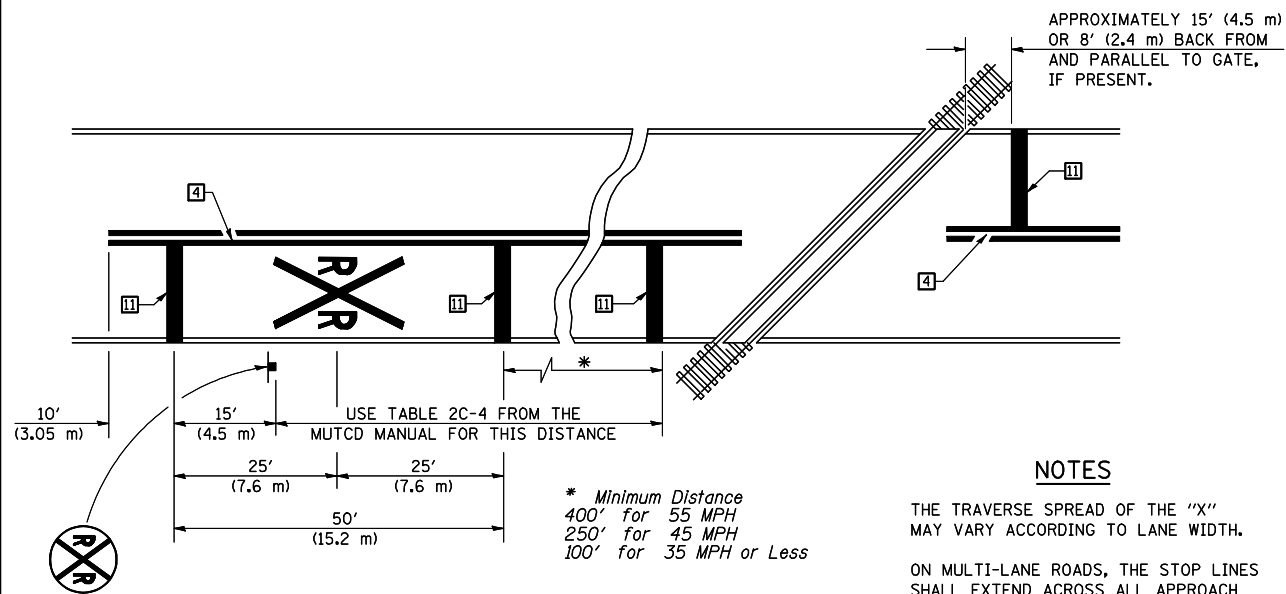

PAVEMENT MARKINGS AT RAILROAD-HIGHWAY GRADE CROSSING

NOTES

THE TRAVERSE SPREAD OF THE "X" MAY VARY ACCORDING TO LANE WIDTH.

ON MULTI-LANE ROADS, THE STOP LINES SHALL EXTEND ACROSS ALL APPROACH LANES AND SEPARATE RXR SYMBOLS SHALL BE PLACED ADJACENT TO EACH OTHER IN EACH LANE.

WHEN THE PAVEMENT MARKING SYMBOL IS USED, A PORTION OF THE SYMBOL SHOULD BE LOCATED DIRECTLY ADJACENT TO THE ADVANCE WARNING SIGN (W10-1) AS PLACED BY TABLE II-1, CONDITION B OF THE MUTCD.

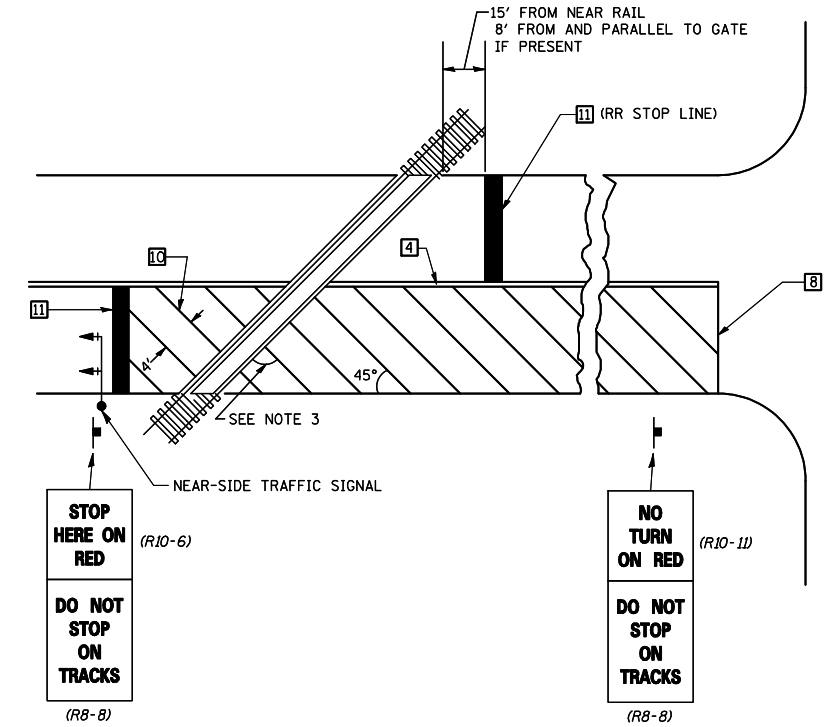
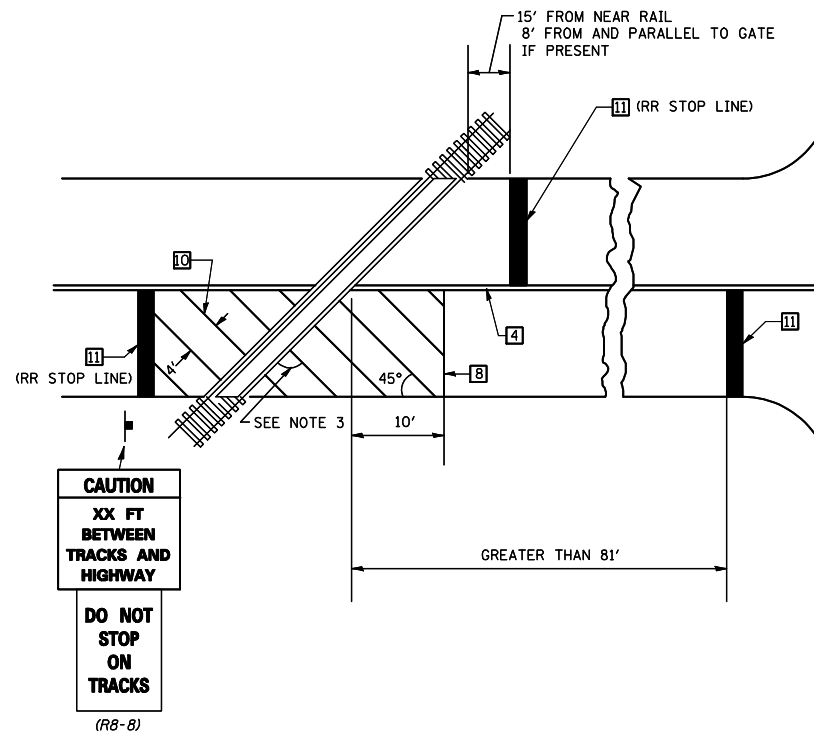

SUPPLEMENTAL PAVEMENT MARKING TREATMENT FOR RAILROAD-HIGHWAY GRADE CROSSING

GENERAL NOTES

- SUPPLEMENTAL PAVEMENT MARKINGS TO BE INSTALLED ONLY ON APPROACHES TO INTERSECTIONS CONTROLLED BY TRAFFIC SIGNALS WHICH ARE INTERCONNECTED WITH THE RAILROAD WARNING SIGNALS.
- EXTEND PAVEMENT MARKINGS TO THE INTERSECTION ONLY WHERE NEAR-SIDE TRAFFIC SIGNALS ARE USED.
- WHERE THE ANGLE BETWEEN THE DIAGONAL PAVEMENT MARKINGS AND THE TRACK WOULD BE LESS THAN 20°, THE PAVEMENT MARKINGS SHOULD BE PLACED IN THE OPPOSITE DIRECTION FROM THAT SHOWN.

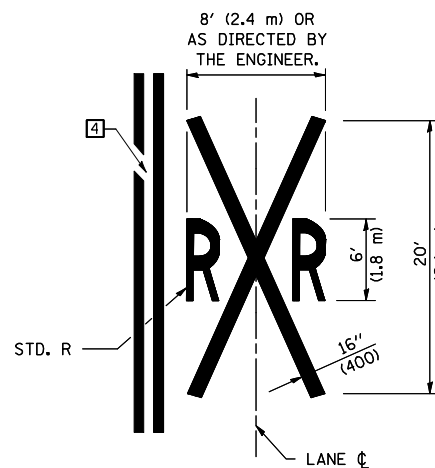

Note: All dimensions are in INCHES (millimeters) unless otherwise shown.

DISTRICT 5 DETAIL NO. 7800AAAA

FILE NAME =	USER NAME = bucklesJJ	DESIGNED -	REVISED - 11/06
ct:\pw\work\PWIDOT\BUCKLESJJ\d0184908.DWG	70784-sht-Details.dgn	DRAWN -	REVISED - 09/2009 - KJT
	PLOT SCALE = 40.0000' / IN.	CHECKED -	REVISED -
	PLOT DATE = 3/15/2010	DATE -	REVISED -

STATE OF ILLINOIS
DEPARTMENT OF TRANSPORTATION

PAVEMENT MARKING AND MARKERS
(RURAL & URBAN APPLICATIONS)

SCALE: SHEET NO. 4 OF 4 SHEETS STA. TO STA.

F.A.P. RTE.	SECTION	COUNTY	TOTAL SHEETS	SHEET NO.
332	47RS-5	VERMILION	41	38
FED. ROAD DIST. NO. ILLINOIS FED. AID PROJECT			CONTRACT NO. 70784	

CENTERLINE INTERSTATE OR MULTI-LANE TWO WAY DIVIDED HIGHWAY

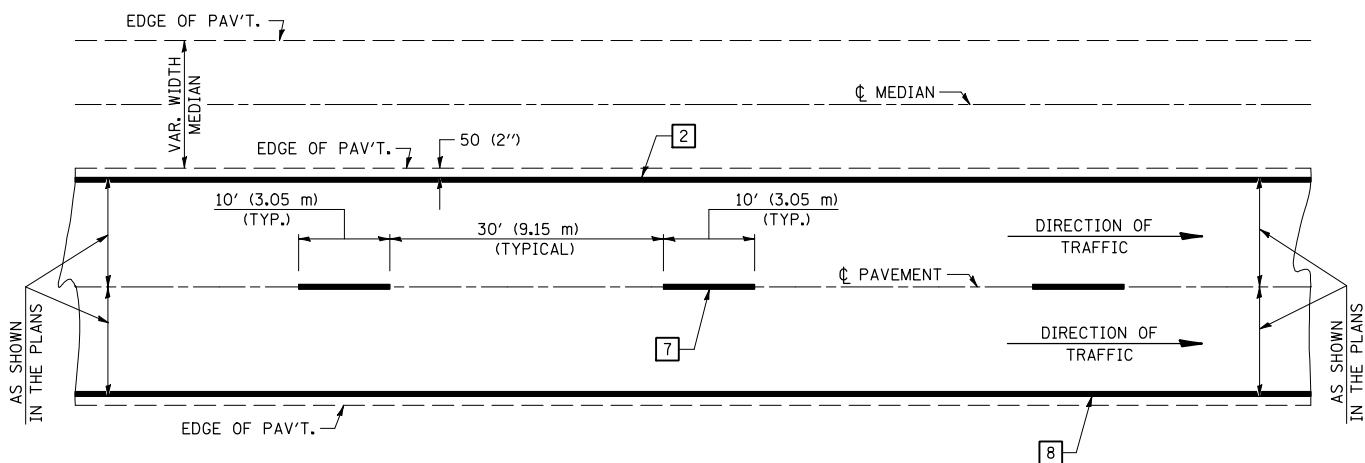

NOTE: PAVEMENT MARKINGS ARE TO BE EXTENDED THROUGH OMISSIONS WHEN APPLICABLE.

NOTE: SEE ARTICLES 780.04 & 781.03 FOR LOCATION OF STRIPES AND MARKERS RELATIVE TO EDGES OR JOINTS.

FOR RAISED REFLECTIVE PAVEMENT MARKERS, REFER TO STANDARD 781001.

TYPICAL EXIT RAMP TERMINAL

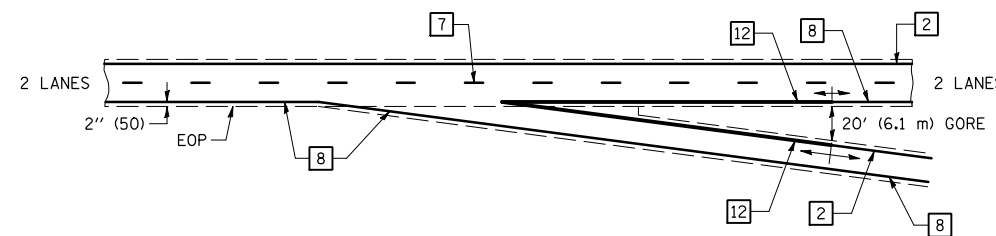

EXIT RAMP TERMINAL with EXCLUSIVE (auxiliary) LANE

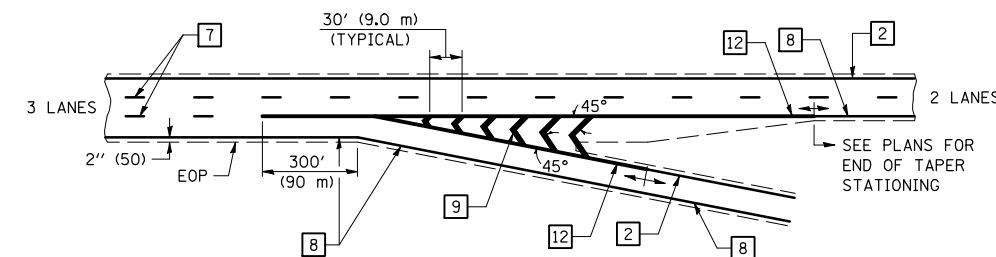

TYPICAL PAVEMENT MARKING LEGEND

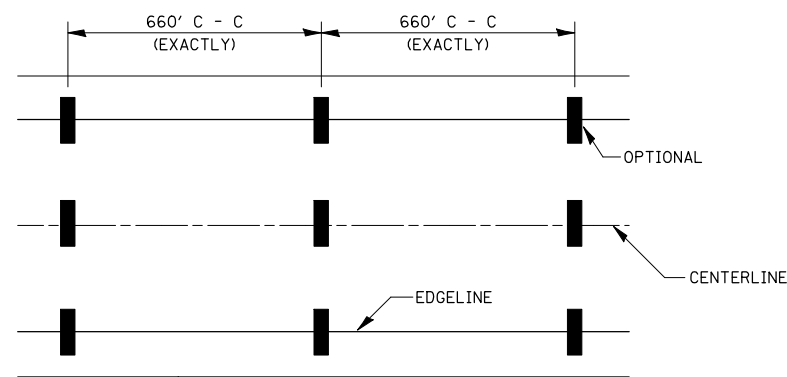

- 1 4" (100) SKIP-DASH (YELLOW)
- 2 4" (100) SOLID (YELLOW)
- 3 12" (300) DIAGONAL (YELLOW)
- 4 4" (100) DOUBLE YELLOW (NARROW)
- 5 RESERVED
- 6 RESERVED
- 7 4" (100) SKIP-DASH (WHITE)
- 8 4" (100) SOLID (WHITE)
- 9 12" (300) DIAGONAL (WHITE)
- 10 6" (150) SOLID (WHITE)
- 11 24" (600) STOP BAR (WHITE)
- 12 8" (200) SOLID (WHITE)
- 13 4" (100) LANE LINE EXTENSIONS (WHITE)

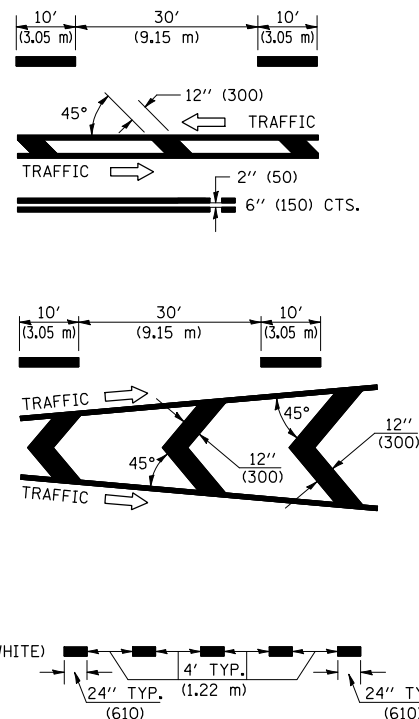

TYPICAL ENTRANCE RAMP TERMINAL

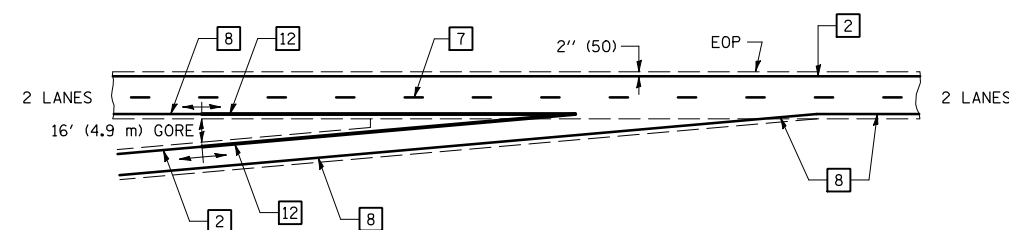

ENTRANCE RAMP TERMINAL with EXCLUSIVE LANE

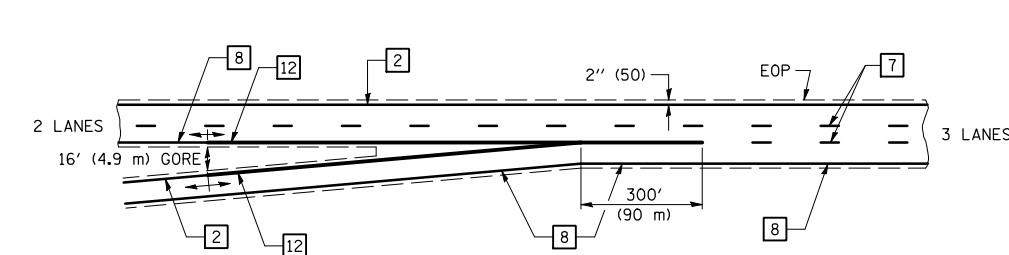

IT WILL BE NECESSARY TO HAVE A REPRESENTATIVE OF THE STATE POLICE PRESENT SO THAT THE ACCURACY OF MEASUREMENT CAN BE ATTESTED TO IN COURT.

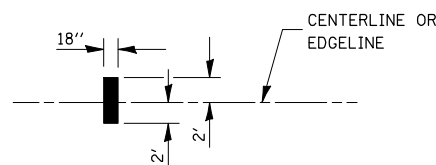

AERIAL SPEED CHECK ZONES

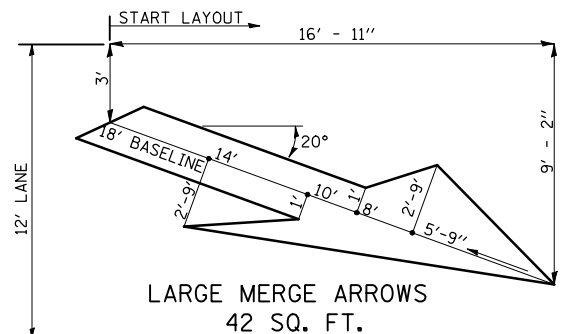

Note: All dimensions are in INCHES (millimeters) unless otherwise shown.

FILE NAME =	USER NAME = bucklesJJ	DESIGNED -	REVISED - 11/06
et:\pw\work\PWIDOT\BUCKLESJJ\d0184908.DWG	70784-sht-Details.dgn	DRAWN -	REVISED -
	PLOT SCALE = 40.0000' / IN.	CHECKED -	REVISED -
	PLOT DATE = 3/15/2010	DATE -	REVISED -

STATE OF ILLINOIS
DEPARTMENT OF TRANSPORTATION

PAVEMENT MARKING (INTERSTATE & MULTI-LANE APPLICATIONS)

SCALE: SHEET NO. OF SHEETS STA. TO STA.

DISTRICT 5 DETAIL NO. 7800BBB

F.A.P. RTE.	SECTION	COUNTY	TOTAL SHEETS	SHEET NO.
332	4TRS-5	VERMILION	41	39
CONTRACT NO. 70784				
FED. ROAD DIST. NO. ILLINOIS FED. AID PROJECT				

XZ193300 – SURVEY MARKER, TYPE 1 (SPECIAL)

TO BE INSTALLED IN FLEXIBLE PAVEMENT OR SHOULDER, BITUMINOUS TREATED SURFACE AND TURF AREAS WITHIN THE RIGHT-OF-WAY FOR PRESERVING PERMANENT SURVEY MARKERS (PI'S, PT'S, PC'S, POC'S, & POT'S)

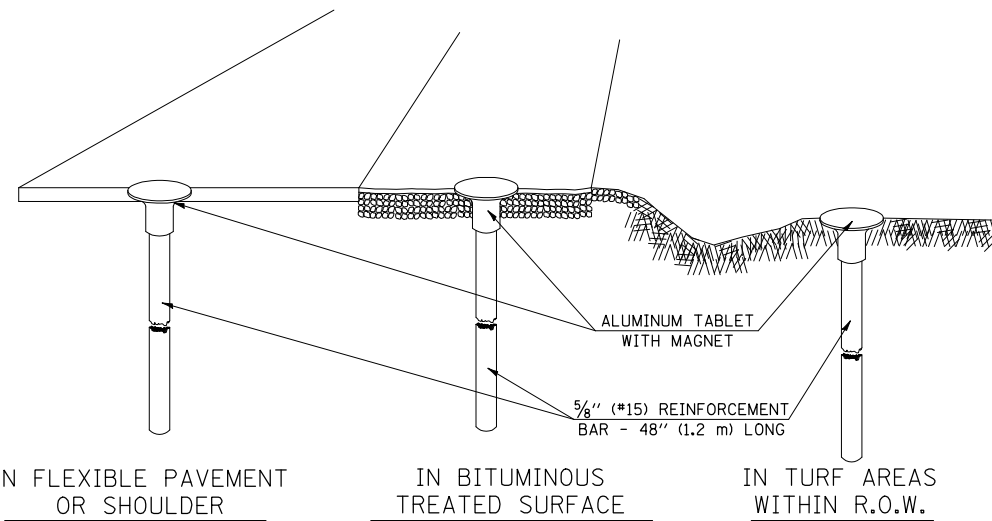

IN FLEXIBLE PAVEMENT OR SHOULDER

IN BITUMINOUS TREATED SURFACE

IN TURF AREAS WITHIN R.O.W.

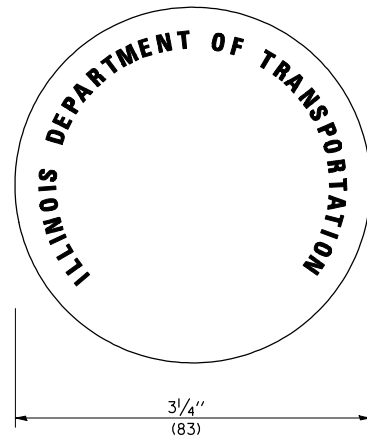
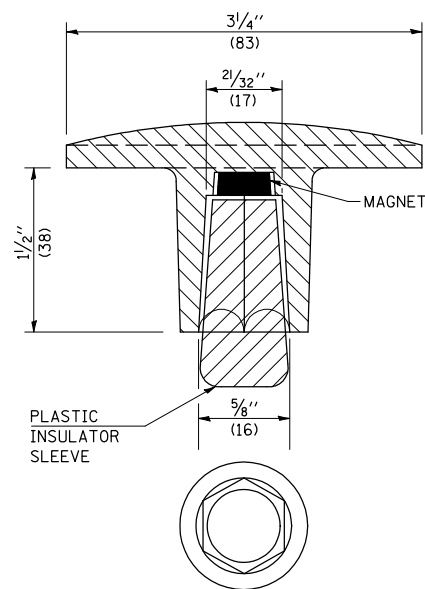

THE DIMENSIONS SHOWN SHALL BE EXACT, OTHERS MAY VARY, BUT SHALL BE SHOWN ON SHOP DRAWINGS.

GENERAL NOTES

1. THE CONTRACT UNIT PRICE, EACH, FOR SURVEY MARKER, TYPE I, (SPECIAL) SHALL BE PAYMENT IN FULL FOR FURNISHING THE SURVEY MARKER.
2. ALL SURVEY MARKERS, TYPE I, (SPECIAL) SHALL BE PLACED $\pm 1/4$ " (6 mm) BELOW THE FINAL SURFACE.
3. WHEN THE TABLET AND REBAR ARE PLACED AS PART OF A SURVEY MARKER VAULT, THEY SHALL BE CONSIDERED AS INCLUDED IN THAT PAY ITEM AND THERE WILL BE NO PAYMENT FOR THE SURVEY MARKER, TYPE I, (SPECIAL).

SPECIFICATIONS FOR ALUMINUM TABLET

SURVEY CAP FOR REBAR. $3/4$ " (83 mm) CONVEX SURVEY CAP FOR $5/8$ " (15 mm) REBAR WITH ILLINOIS DEPARTMENT OF TRANSPORTATION LOGO. THIS LOGO SHALL PROVIDE LETTERS RECESSED INTO THE SURFACE A MINIMUM OF $1/32$ " (0.8 mm) FOR EASY AND LONG-TERM LEGIBILITY. THE ALUMINUM CAP FOR REBAR SHALL BE PRODUCED BY THE PROCESS OF ORBITAL FORGING TO PRODUCE A HIGH-STRENGTH AND DURABLE MARKER CAP WHICH WILL NOT CHIP OR BREAK AND PROVIDE A SMOOTH FINISH FOR STAMPING OF DATA IN THE FIELD. THE ALUMINUM CAP FOR REBAR SHALL BE TAPERED FOR A PERFECT COMPRESSION FIT. A SPECIAL PLASTIC INSULATOR SHALL BE INSTALLED TO PREVENT DISSIMILAR METAL CONTACT AND CORROSION. THE PLASTIC INSULATOR SHALL FORM READILY TO THE OUTER SHAPE OF THE REBAR AND TO THE INNER SHAPE OF THE ALUMINUM CAP SOCKET. THE PLASTIC INSULATOR SHALL BE LOW DENSITY POLYETHYLENE, A MINIMUM $1/2$ " (38 mm) LONG AND CONFORM TO FEDERAL SPECIFICATION L-P 390.

COMPOSITION: ALUMINUM 98.3-98.7%; OTHER 1.3-1.7%; STRENGTH: YIELD 28 KSI (193 MPa), ULTIMATE 32 KSI (221 MPa). ELONGATION 15% [IN 2" (50 mm)]. SPECIFICATIONS: ALUMINUM ALLOY 6101-0; ASTM B317-83 (EXCEPT TEMPER) AS FORGED. NO EXCEPTIONS.

SPECIFICATIONS FOR REBAR

REBAR FOR ALUMINUM TABLET. REINFORCEMENT BAR SHALL BE $5/8$ " (#15) X 48" (1.2 m) (DEFORMED).

INSPECTION OF REINFORCEMENT BAR $5/8$ " (#15) SHALL BE DONE BY DISTRICT PERSONNEL OF THE ILLINOIS DEPARTMENT OF TRANSPORTATION, DIVISION OF HIGHWAYS.

XZ193400 – SURVEY MARKER, TYPE 2 (SPECIAL)

TO BE INSTALLED IN RIGID OR COMPOSITE PAVEMENT FOR PRESERVING PERMANENT SURVEY MARKERS (PI'S, PT'S, PC'S, POC'S, & POT'S)

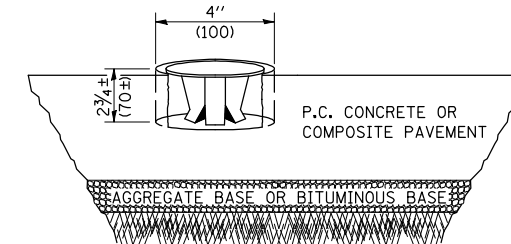

SPECIFICATIONS FOR ALUMINUM TABLET (FORKED)

ALUMINUM TABLET (FORKED) FOR USE WITH "SURVEY MARKER, TYPE 2, (SPECIAL)" SHALL BE AS SHOWN ON THE DETAIL FOR THE $3/4$ " (83 mm) CONVEX SURVEY TABLET WITH ILLINOIS DEPARTMENT OF TRANSPORTATION LOGO. THIS LOGO SHALL PROVIDE FOR LETTERS RECESSED INTO THE SURFACE A MINIMUM OF $1/32$ " (0.8 mm) FOR EASY AND LONG-TERM LEGIBILITY. THE ALUMINUM TABLET SHALL BE PRODUCED BY THE PROCESS OF ORBITAL FORGING TO PRODUCE A HIGH-STRENGTH AND DURABLE MARKER CAP WHICH WILL NOT CHIP OR BREAK AND PROVIDE A SMOOTH FINISH FOR STAMPING OF DATA IN THE FIELD. THE ALUMINUM TABLET SHALL BE DESIGNED NOT TO TURN OR ROTATE. THREE PRONGS ON A $2/2$ " (63 mm) STEM SHALL BE SUCH THAT THE ALUMINUM TABLET CANNOT BE EASILY REMOVED.

COMPOSITION: ALUMINUM 92-93%; MAGNESIUM 6.5-7.5%. STRENGTH: YIELD 19,000-21,000 PSI (131-145 MPa); TENSILE 38,000-44,000 PSI (262-303 MPa); ELONGATION 10-15% [IN 2" (50 mm)]. SPECIFICATIONS: ALLOY 535.0; QQ-A-601ES. NO EXCEPTIONS.

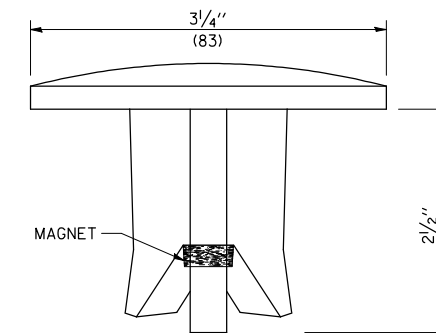

SIDE VIEW

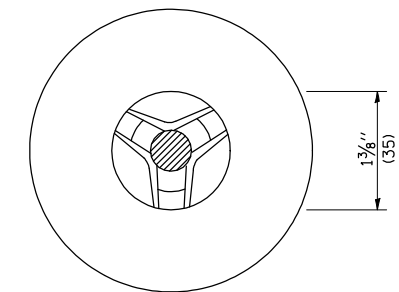

BOTTOM VIEW

THE DIMENSIONS SHOWN SHALL BE EXACT, OTHERS MAY VARY, BUT SHALL BE SHOWN ON SHOP DRAWINGS.

GENERAL NOTES

1. WORK ON THIS ITEM SHALL NOT START UNTIL THE FINAL SURFACE IS COMPLETED.
2. THE ALUMINUM TABLET (FORKED) SHALL REST UPON THE BOTTOM OF THE 4" (100 mm) CORE HOLE. IF THE HOLE IS TOO DEEP, EPOXY GROUT MUST BE USED TO DECREASE THE DEPTH AND ALLOWED TO HARDEN BEFORE PROCEEDING.
3. THE ALUMINUM TABLET SHALL BE ANCHORED IN THE 4" (100 mm) DIAMETER HOLE IN THE NEW PAVEMENT WITH TWO-COMPONENT EPOXY CONFORMING TO APPLICABLE PORTIONS OF ARTICLE 1025.01 OF THE STANDARD SPECIFICATIONS.
4. THE 4" (100 mm) CORE HOLE SHALL BE SUBJECT TO THE APPROVAL OF THE ENGINEER.
5. THE CONTRACT PRICE, EACH, FOR SURVEY MARKER, TYPE 2 (SPECIAL) SHALL BE PAYMENT IN FULL FOR FURNISHING THE ALUMINUM TABLET AND ALL LABOR AND MATERIAL TO SET THE MARKER IN PLACE, AS SPECIFIED, INCLUDING CORING THE NEW PAVEMENT.
6. ALL SURVEY MARKERS, TYPE 2 (SPECIAL) SHALL BE PLACED $\pm 1/4$ " (6 mm) BELOW THE FINAL SURFACE.

Note: All dimensions are in INCHES (millimeters) unless otherwise shown.

FILE NAME =	USER NAME = bucklesjj	DESIGNED -	REVISED - 11/06
ct:\pw\work\PIWIDOT\BUCKLESJJ\d0184908.D	70784-sht-Details.dgn	DRAWN -	REVISED -
	PLOT SCALE = 40.0000 ' / IN.	CHECKED -	REVISED -
	PLOT DATE = 3/15/2010	DATE -	REVISED -

STATE OF ILLINOIS
DEPARTMENT OF TRANSPORTATION

SURVEY MARKERS TYPE 1 & 2 (SPECIAL)

SCALE: SHEET NO. OF SHEETS STA. TO STA.

DISTRICT 5 DETAIL NO. XZ193AAA

F.A.P. RTE.	SECTION	COUNTY	TOTAL SHEETS	SHEET NO.
332	4TRS-5	VERMILION	41	
FED. ROAD DIST. NO. ILLINOIS FED. AID PROJECT				CONTRACT NO. 70784

TO BE INSTALLED IN ALL PAVEMENT TYPES FOR PRESERVING PERMANENT SURVEY MARKERS (PI'S, PT'S, PC'S, POC'S, & POT'S) AND LAND SURVEY MONUMENTS (SECTION OR SUBSECTION CORNERS)

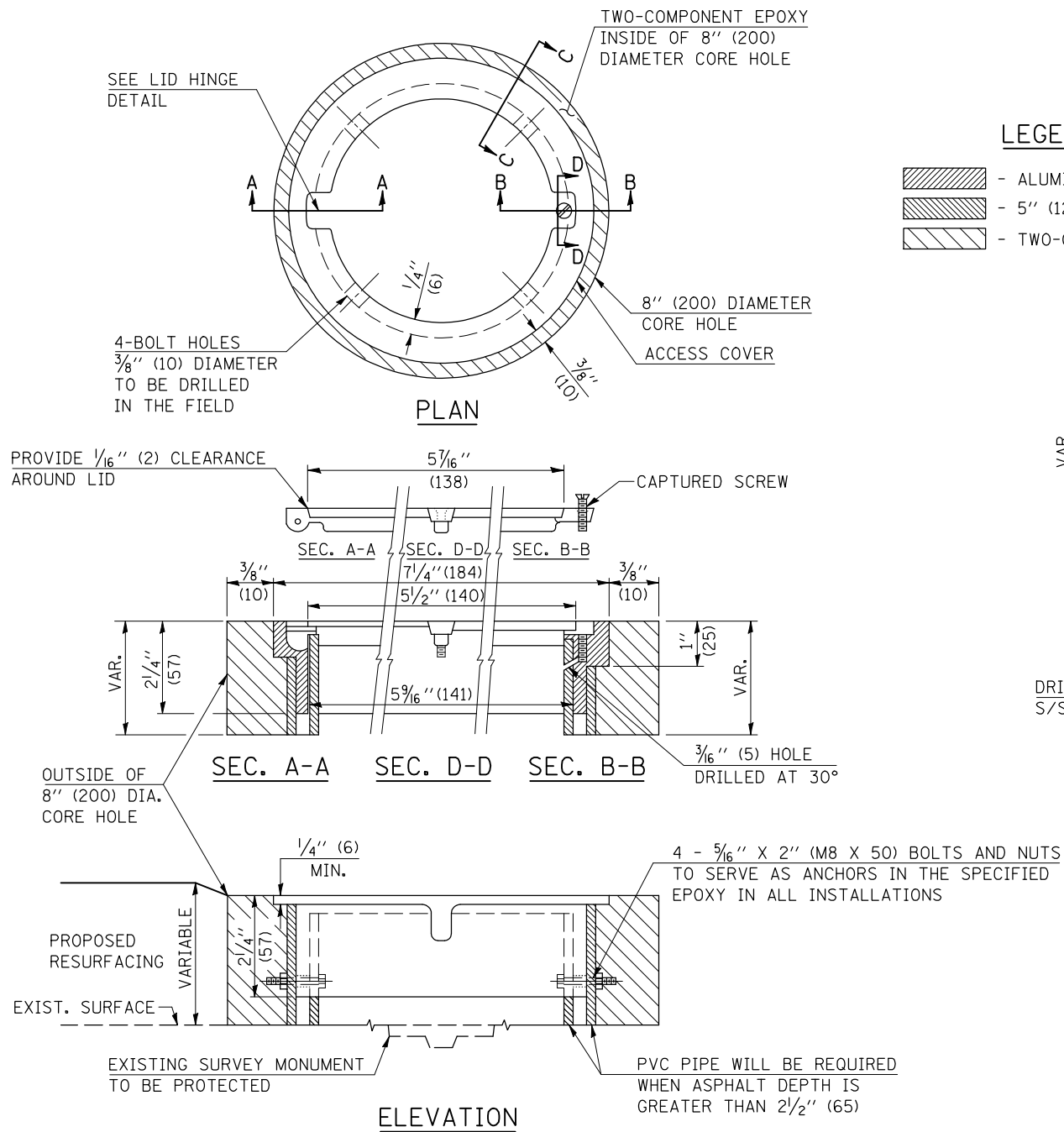

LEGEND

- ALUMINUM CASTING
- 5" (125) OR 6" (150) P.V.C. PIPE
- TWO-COMPONENT EPOXY

SPECIFICATIONS FOR ACCESS COVER FOR USE WITH SURVEY MARKER VAULT(S) AND SURVEY MARKER COVER ASSEMBLY(S): THE ACCESS COVER WILL BE CAST FROM A SPECIAL ALUMINUM ALLOY THAT IS COMPARABLE TO BRONZE IN HARDNESS. THE ACCESS COVER SHALL BE SPECIALLY ENGINEERED AND DESIGNED TO PROVIDE A SNUG FIT, INCORPORATING EQUIDISTANT LOCKING RIDGES, INSIDE A STANDARD 6" (150 mm) DIAMETER, OR OUTSIDE A STANDARD 5" (125 mm) DIAMETER, SCHEDULE 40 PVC PIPE. THE ACCESS COVER SHALL HAVE SPECIAL UNIFORM 1" (25 mm) THICK TOP SURFACE TO PERMIT INFORMATION TO BE EASILY MACHINE-STAMPED INTO IT. THE ACCESS COVER SHALL INCLUDE A STAINLESS CAPTURED SCREW AND AN OPPOSING RECESSED HINGE ASSEMBLY AS ITS LOCKING MECHANISM. THE ACCESS COVER SHALL INCORPORATE A SPECIAL ACCESS HOLE FOR CLEANING AND DRAINAGE, DRILLED AT 30° INSIDE THE RING OF THE ACCESS COVER, TO THE DRILLED AND TAPPED HOLE PROVIDED FOR THE STAINLESS CAPTURED SCREW. COMPOSITION: ALUMINUM 92-93%; MAGNESIUM 6.5-7.5%. STRENGTH: YIELD - 19,000-21,000 PSI (131-145 MPa); TENSILE - 38,000-44,000 PSI (262-303 MPa); ELONGATION - 10-15% IN 2" (50 mm). SPECIFICATIONS: ALLOY 535.0; Q0-A-601Es. NO EXCEPTIONS.

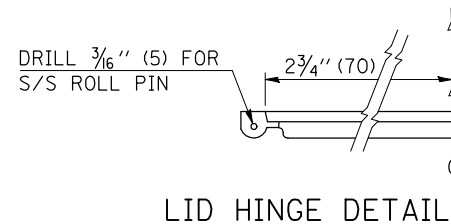

BILL OF MATERIAL

ALUMINUM CASTING OF THE DIMENSIONS AND SPECIFICATIONS SHOWN OR OTHER SUBJECT TO ENGINEER'S APPROVAL OF SHOP DRAWINGS, 4 EACH - 5/16" X 2" (M8 X 50) BOLTS WITH NUTS, EPOXY, 5" OR 6" (125 mm OR 150 mm) DIAMETER P.V.C. PIPE, SCHEDULE 40 (WHEN REQUIRED).

GENERAL NOTES

1. WORK SHALL NOT START ON THIS ITEM UNTIL THE FINAL LIFT OF SURFACE HAS BEEN COMPLETED.
2. THE SURVEY MONUMENT COVER ASSEMBLY SHALL BE CENTERED ABOVE THE SURVEY MONUMENT TO BE PROTECTED.
3. MODIFICATION OF THE ALUMINUM CASTING SHALL BE DONE BY GRINDING OR SAWING WHEN HEIGHT REDUCTION IS REQUIRED.
4. ALL SURVEY MONUMENT COVER ASSEMBLIES SHALL BE PLACED 1/4" (6 mm) ± BELOW THE FINAL SURFACE.
5. ALUMINUM CASTING SHALL BE PLACED OVER A 5" (125 mm) P.V.C. PIPE OR INSIDE OF A 6" (150 mm) P.V.C. PIPE WHEN AN INCREASE IN HEIGHT IS REQUIRED.
6. THE CASTING SHALL BE ANCHORED IN THE 8" (200 mm) DIAMETER CORE HOLE WITH TWO-COMPONENT EPOXY CONFORMING TO APPLICABLE PORTIONS OF ARTICLE 1025.01 OF THE STANDARD SPECIFICATIONS.
7. THIS WORK WILL BE PAID FOR AT THE CONTRACT UNIT PRICE EACH FOR SURVEY MONUMENT COVER ASSEMBLY WHICH PRICE SHALL INCLUDE ALL LABOR AND MATERIAL AS SPECIFIED INCLUDING CORING THE NEW PAVEMENT SURFACE AND EPOXY. NO ADDITIONAL COMPENSATION WILL BE ALLOWED.
8. THE 8" (200 mm) DIAMETER CORE HOLE SHALL BE SUBJECT TO THE APPROVAL OF THE ENGINEER.

Note: All dimensions are in INCHES (millimeters) unless otherwise shown.

FILE NAME =	USER NAME = bucklesjj	DESIGNED -	REVISED - 11/06
ct:\pw\work\PWIDOT\BUCKLESJJ\d0184908\0970784-sht-Details.dgn		DRAWN -	REVISED -
		CHECKED -	REVISED -
		DATE -	REVISED -

**STATE OF ILLINOIS
DEPARTMENT OF TRANSPORTATION**

SURVEY MONUMENT COVER ASSEMBLY

SCALE: SHEET NO. OF SHEETS STA. TO STA.

DISTRICT 5 DETAIL NO. Z0070100

F.A.P. RTE.	SECTION	COUNTY	TOTAL SHEETS	SHEET NO.
332	4TRS-5	VERMILION	41	41
CONTRACT NO. 70784				
FED. ROAD DIST. NO. ILLINOIS FED. AID PROJECT				