

STATE OF ILLINOIS
DEPARTMENT OF TRANSPORTATION

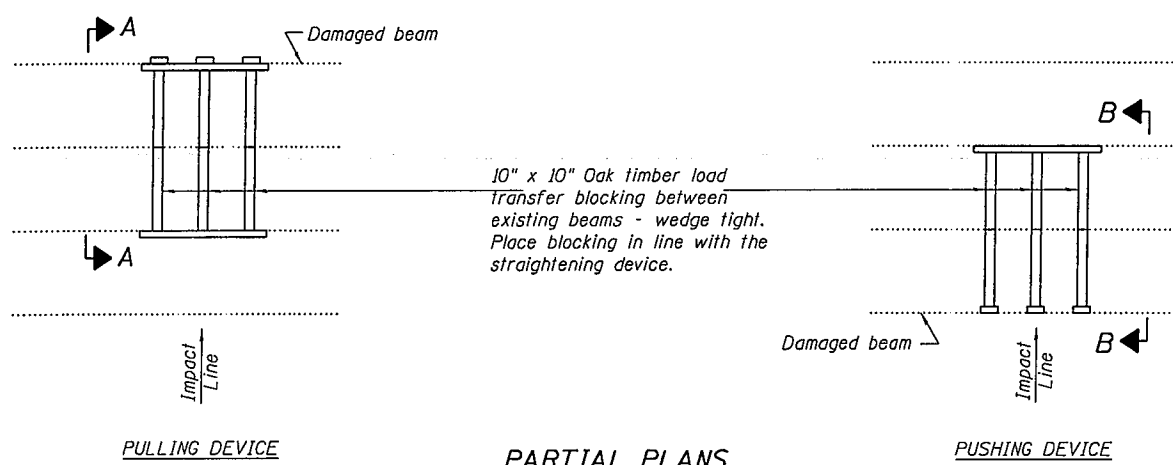

SUGGESTED BEAM STRAIGHTENING METHODS

Straightening force shall be maintained on all load transfer blocking during beam straightening.

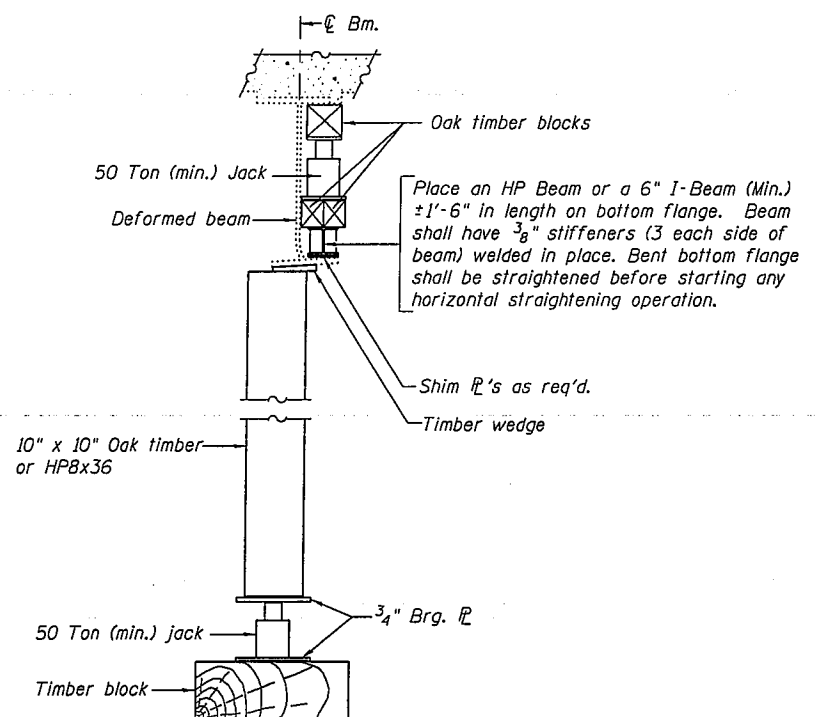

SUGGESTED VERTICAL STRAIGHTENING DETAIL
(To correct localized vertical flange deformations.)

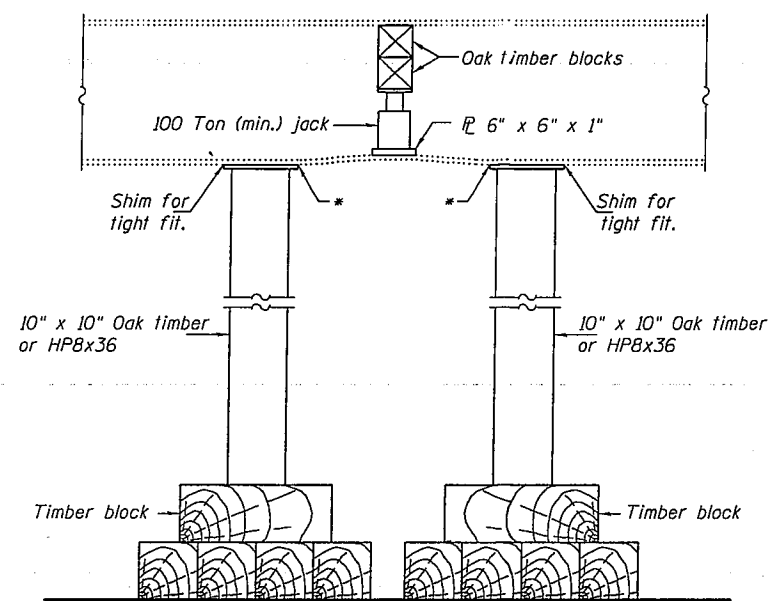

SUGGESTED VERTICAL STRAIGHTENING DETAIL
(To correct localized vertical flange deformations.)

* Edge of plate shall line up with edge of deformation.

Note:
Braces and jack assembly shall be placed on same side of web.
Bent bottom flange shall be straightened before starting any horizontal straightening operations.

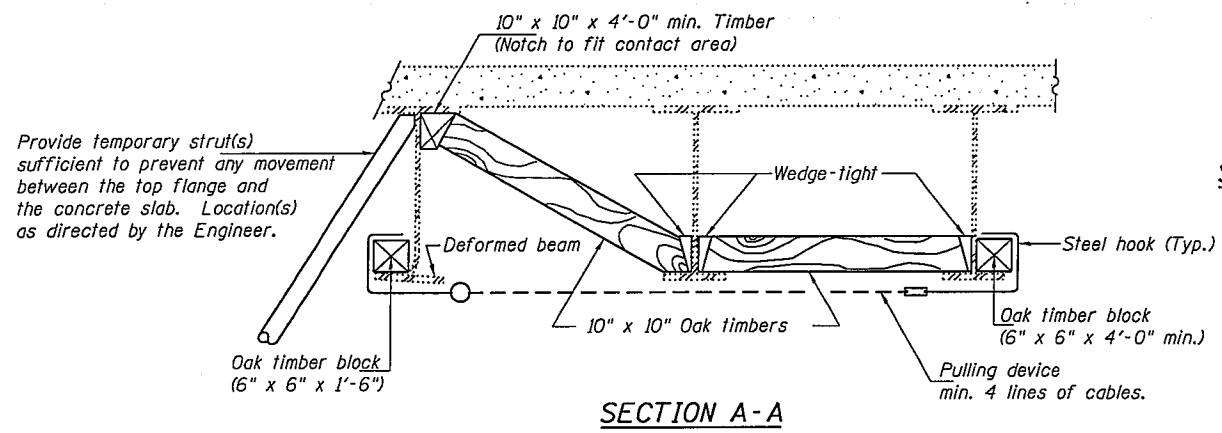

SECTION A-A

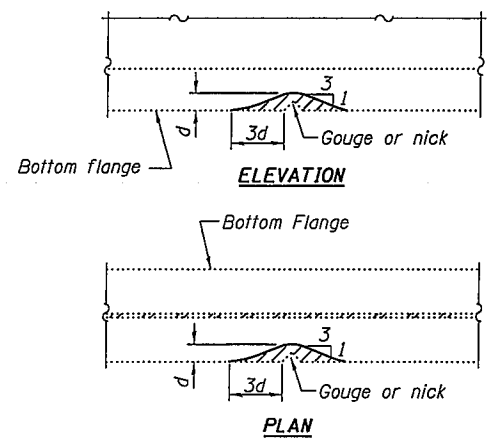

GRINDING DETAIL

Grind existing nicks, gouges and shallow cracks in the damaged beams as detailed. Ground surfaces shall be inspected for cracks using magnetic particle testing prior to initiating any beam straightening operations. Any cracks that cannot be removed by grinding approximately 1/4" deep shall be identified and reported to the Bureau of Bridges and Structures for further disposition. Ground surfaces shall be spot cleaned and painted with an aluminum epoxy mastic primer followed by a finish coat to match the color of the existing beam. Cost of grinding, testing and spot painting included with Beam Straightening.

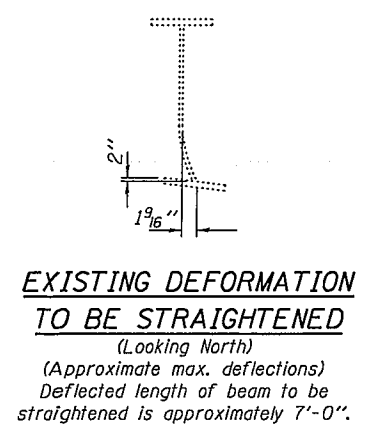

REPAIR DETAILS
CH 19 OVER I-72
SN 010-0146

DESIGNED	VHV
CHECKED	ATH
DRAWN	ballva
CHECKED	VHV ATH

APRIL 13, 2010
EXAMINED *Carl Proyer*
ENGINEER OF STRUCTURAL SERVICES
PASSED *Ralph E. Anderson*
ENGINEER OF BRIDGES AND STRUCTURES

REP-1 1-14-2005

SHEET NO. 2	F.A.I. RTE.	SECTION	COUNTY	TOTAL SHEETS	SHEET NO.
	72	(10-71HB)BDR,BJR	CHAMPAIGN	14	8
3 SHEETS	CONTRACT NO. 70865				
FED. ROAD DIST. NO.		ILLINOIS	FED. AID PROJECT		