

TEMPORARY SIGNAL NOTES:

1. TEMPORARY CABINET TO BE FURNISHED BY CONTRACTOR AND EQUIPPED WITH VIDEO DETECTION INTERFACE CABLES.
2. TEMPORARY SIGNALS SHALL BE OPERATIONAL PRIOR TO REMOVAL OF EXISTING SIGNALS.
3. POLES SHALL BE GUYED OR ANCHORED TO THE SATISFACTION OF THE ENGINEER. ANY ADJUSTMENTS SHALL BE CONSIDERED PART OF THE PAY ITEM FOR TEMPORARY TRAFFIC SIGNAL INSTALLATION.
4. THE PROP VIDEO DETECTION SYSTEM SHALL BE UTILIZED TO PROVIDE DETECTION FOR THE TEMPORARY CONTROLLER, THE CAMERAS AND CONTROL UNIT SHALL BE RELOCATED TO THE PERMANENT TRAFFIC SIGNAL INSTALLATION. ALL ADJUSTMENTS AND RELOCATION OF VIDEO COMPONENTS ARE TO BE INCLUDED IN THE TEMPORARY TRAFFIC SIGNAL INSTALLATION COST.
5. POLES USED FOR TEMPORARY SIGNAL INSTALLATION SHALL PROVIDE FOR A MINIMUM 35 FT. MOUNTING HEIGHT FOR THE VIDEO CAMERAS.
6. PROPOSED SERVICE TO BE UTILIZED FOR TEMPORARY AND PROPOSED SIGNALS

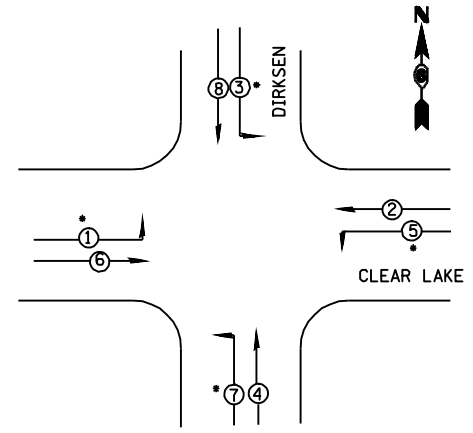

TEMPORARY PHASE DESIGNATION DIAGRAM

PHASES 1 AND 5 SHALL BE PROGRAMMED TO NEVER SERVE SIMULTANEOUSLY. PHASE 5 SHALL BE PROGRAMMED TO LAG.

PHASES 3 AND 7 SHALL BE PROGRAMMED TO NEVER SERVE SIMULTANEOUSLY. PHASE 7 SHALL BE PROGRAMMED TO LAG.

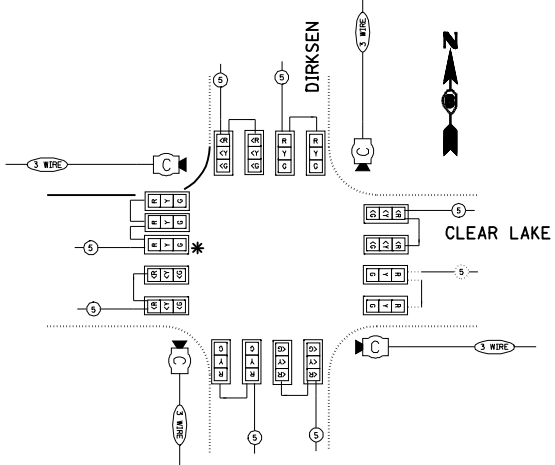
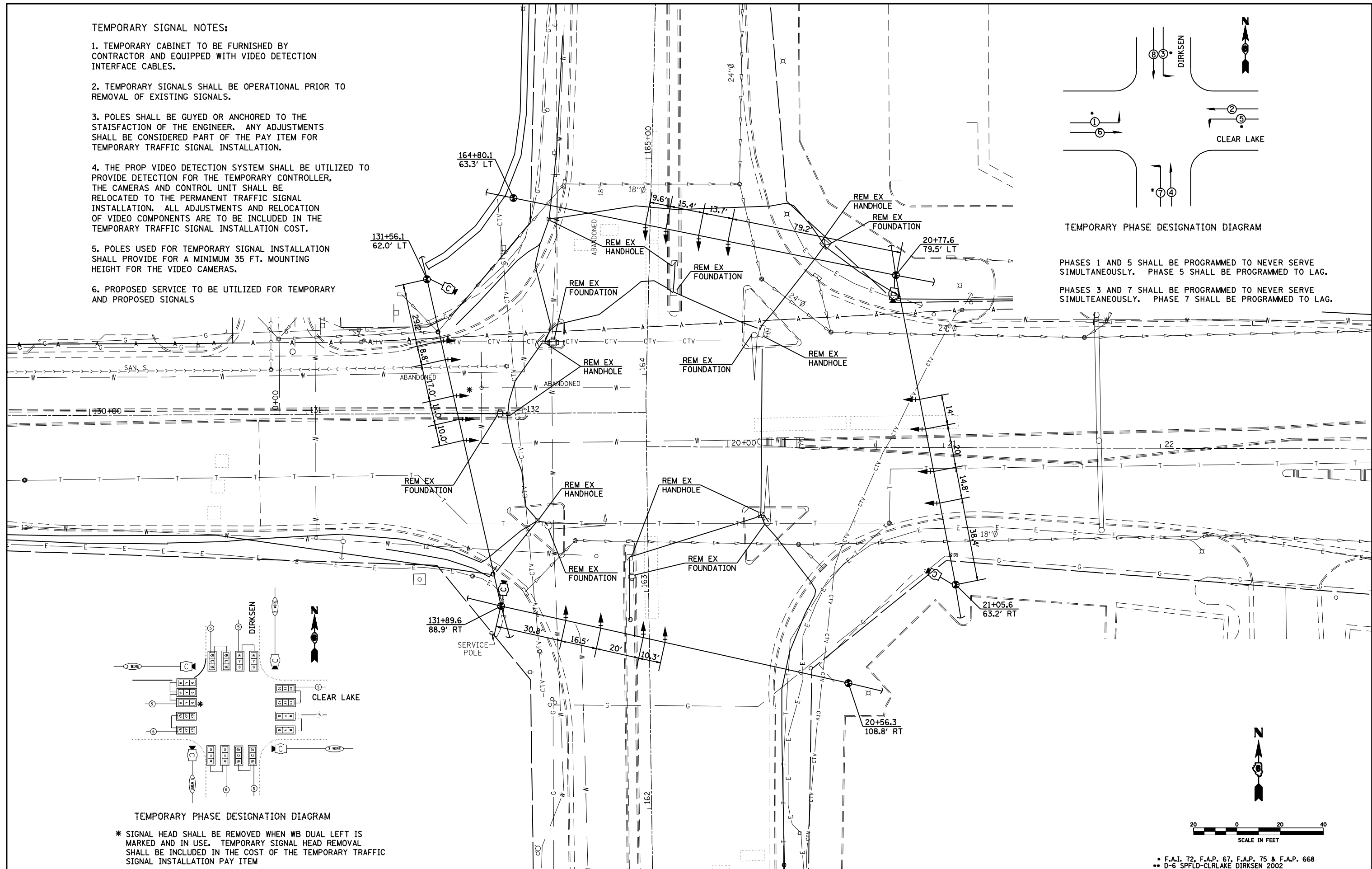

TEMPORARY PHASE DESIGNATION DIAGRAM

* SIGNAL HEAD SHALL BE REMOVED WHEN WB DUAL LEFT IS MARKED AND IN USE. TEMPORARY SIGNAL HEAD REMOVAL SHALL BE INCLUDED IN THE COST OF THE TEMPORARY TRAFFIC SIGNAL INSTALLATION PAY ITEM

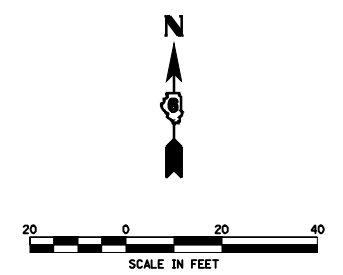

FILE NAME =	USER NAME = laughlinr1	DESIGNED -	REVISED -
er:\pwork\PWIDOT\LAUGHLINRL\0183448\TS_Sheets.dgn		DRAWN -	REVISED -
PLOT SCALE = 40.0000' / IN.		CHECKED -	REVISED -
PLOT DATE = Feb-08-2010 02:50:39PM		DATE -	REVISED -

**STATE OF ILLINOIS
DEPARTMENT OF TRANSPORTATION**

SCALE:	SHEET NO.	OF SHEETS	STA.	TO STA.
--------	-----------	-----------	------	---------

* F.A.I. 72, F.A.P. 67, F.A.P. 75 & F.A.P. 668				
** D-6 SPFLD-CLRLAKE DIRKSEN 2002				
F.A. RTE.	SECTION	COUNTY	TOTAL SHEETS	SHEET NO.
*	**	SANGAMON	363	178
CONTRACT NO. 72088				
FED. ROAD DIST. NO.	ILLINOIS FED. AID PROJECT			