

STATE OF ILLINOIS
DEPARTMENT OF TRANSPORTATION

F.A.P. RTE.	SECTION	COUNTY	TOTAL SHEETS	SHEET NO.
317	**	*	196	106
STA. 420+00.00 TO STA. 454+00.00				
FED. ROAD DIST. NO. ILLINOIS FED. AID PROJECT				

* BROWN & SCHUYLER CONTRACT NO. 72432
** 9RS-4, (10,11) RS-3; (10B-1) R
SHEET 34 OF 123

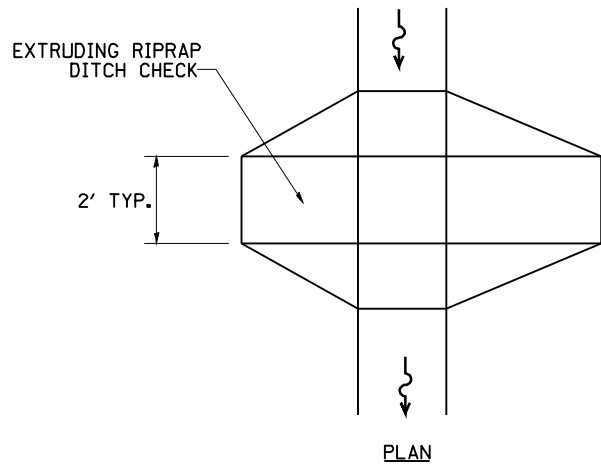

PLAN

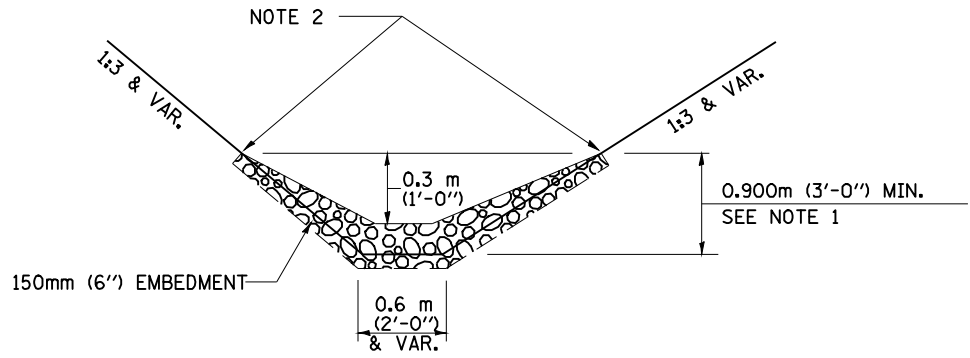

ELEVATION
OPTION 1

(EXTRUDING DITCH CHECK)
RECOMMENDED FOR AREAS
W/ RIPRAP DITCH LINING

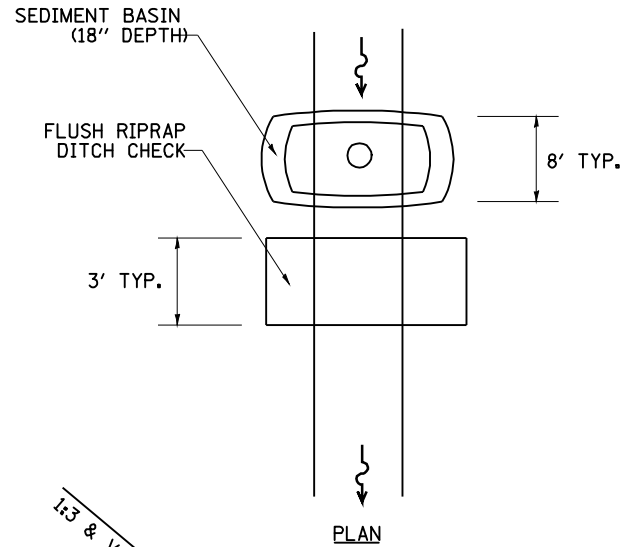

PLAN

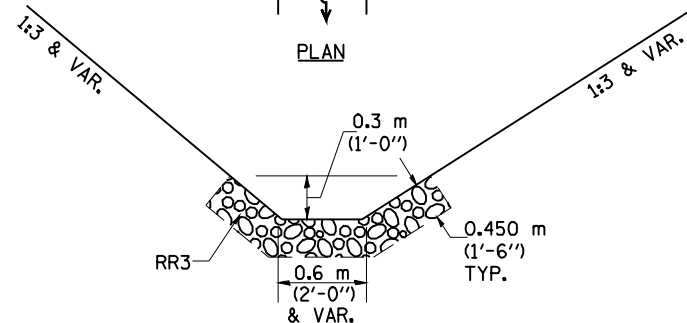

ELEVATION
OPTION 2

(FLUSH DITCH CHECK)
RECOMMENDED FOR AREAS
W/O RIPRAP DITCH LINING

AGGREGATE DITCH CHECKS

(TYPICAL & OPTIONS 1 & 2
AS DIRECTED BY THE ENGINEER)

NOTE 1: RIPRAP SHALL EXTEND FAR ENOUGH UP THE SLOPES TO ALLOW 0.3m (1') OVERTOPPING TO AVOID ERODING AROUND THE EDGES OF THE RIPRAP.

NOTE 2: ENDS SHALL BE TIED INTO SLOPES.

LEGEND FOR STORM WATER POLLUTION PREVENTION PLAN

ITEM	SYMBOL
AGGREGATE (EROSION CONTROL) [AGGREGATE DITCH CHECKS: Height = 0.6m (2')]	
TEMPORARY DITCH CHECKS	
INLET PIPE PROTECTION (I&PP)	
EROSION CONTROL FENCE	
EARTH EXCAVATION FOR EROSION CONTROL (SEDIMENT BASINS)	
PRESERVE EXISTING TREES, WOODLANDS, AND UNDERSTORY (OUTSIDE CONSTRUCTION LIMITS)	
ITEM PLACED AT BEGINNING OF CONSTRUCTION (Requirement)	
ITEM PLACED AS DIRECTED BY ENGINEER (When required by situation)	
DIRECTION OF OVERLAND FLOW	
EROSION CONTROL FIBER BLANKET	

GENERAL NOTES:

All Items shall be constructed as shown on this sheet, on Standard 280001, and as directed by the Engineer.

The symbology on the STORM WATER POLLUTION PREVENTION PLAN sheets does not represent the size or quantity of bales, for number of bales refer to details and notes shown on this sheet and/or as directed by the Engineer.

THE CONTRACTOR SHALL INSTALL DITCH CHECKS AS DIRECTED BY THE ENGINEER. IF THE ENGINEER ELECTS TO UTILIZE FLUSH RIPRAP DITCH CHECKS IN LIEU OF TEMPORARY DITCH CHECKS AS SHOWN ON THE FOLLOWING PLAN SHEETS, THE SPACING SHOULD BE DOUBLED.

**STORMWATER POLLUTION
PREVENTION PLANS**
SHEET 1 OF 6
US 24 OVER LAMOINE RIVER
F.A.P. RTE 317 (US RTE 24)
SECTION 9RS-4, (10,11) RS-3; (10B-1) R
BROWN & SCHUYLER COUNTIES