

DETAILS OF MAILBOX TURNOUTS

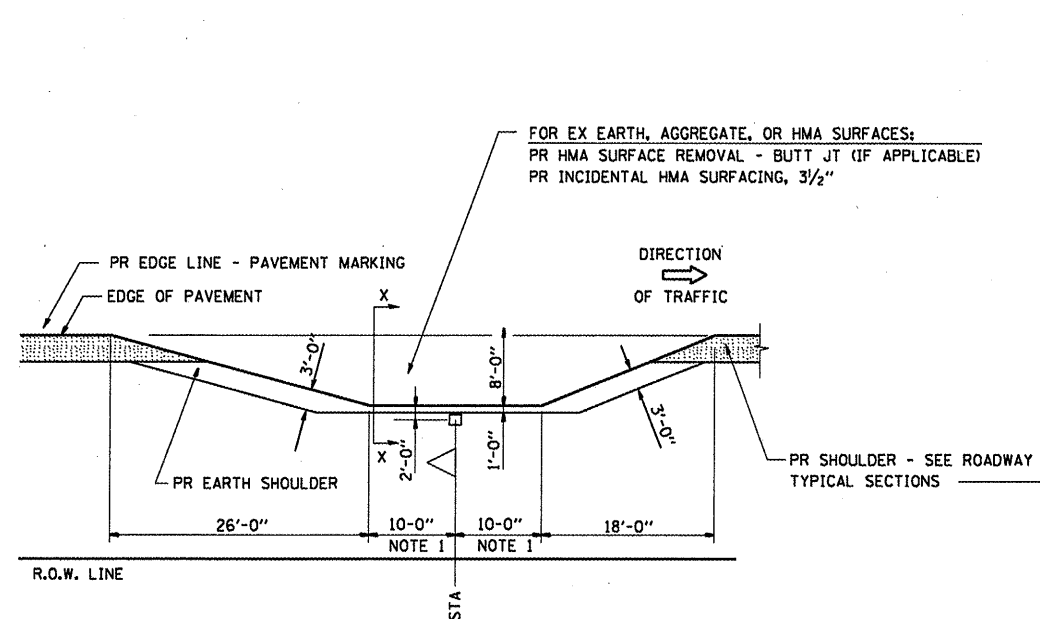

PLAN - MAILBOX TURNOUTS

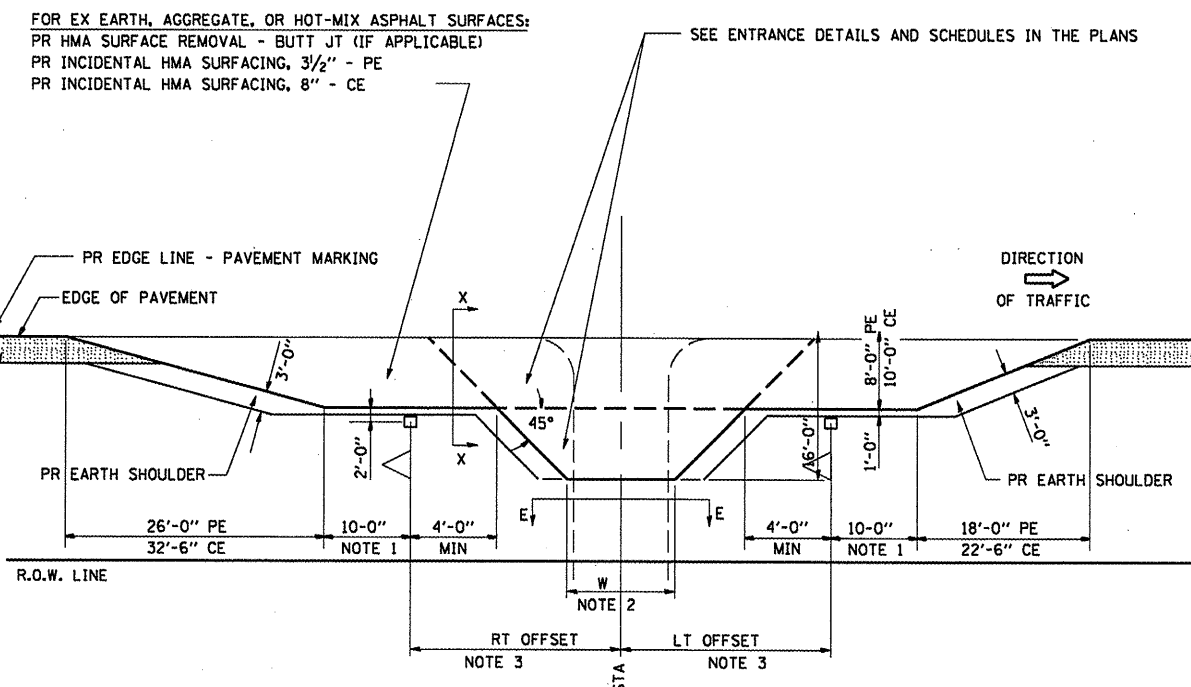

PLAN - COMBINED MAILBOX TURNOUT WITH TRAILING OR LEADING ENTRANCE

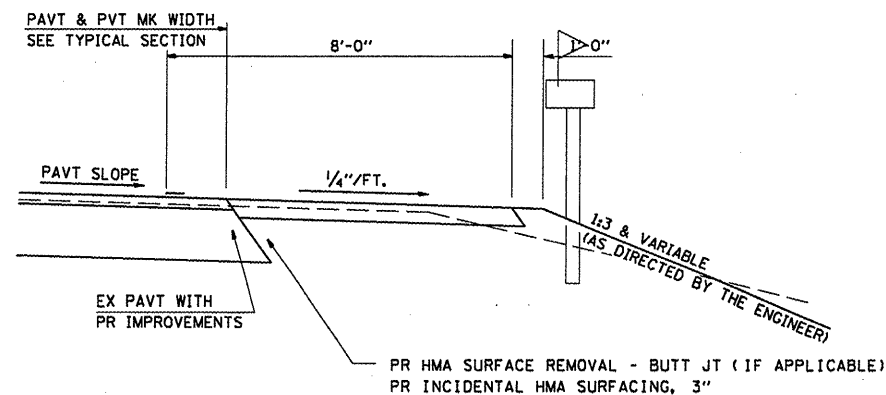

SECTION X-X THRU MAILBOX TURNOUT
ALSO APPLIES TO MAILBOX TURNOUTS COMBINED WITH
EX EARTH, AGGREGATE, OR HOT-MIX ASPHALT PE & FE

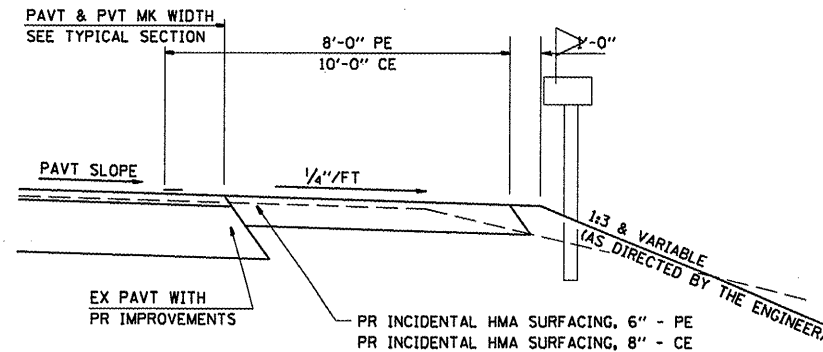

SECTION X-X THRU MAILBOX TURNOUT
COMBINED WITH EX HMA & PC CONC PE & CE

- NOTE 1 IF MORE THAN ONE MAILBOX IS PRESENT, DIMENSION FROM CENTER OF END MAILBOX.
- NOTE 2 FOR ENTRANCE LAYOUT DIMENSIONS AND SECTIONS A-A & E-E REFER TO THE SCHEDULES IN THE PLANS.
- NOTE 3 BOTH LT OR RT OFFSETS FOR MAILBOX SHOWN USE OFFSET DIMENSION PER SCHEDULE AND REFER TO LAYOUT SHOWN ON THE PLAN.

ALL DIMENSIONS ARE IN INCHES
UNLESS OTHERWISE SHOWN.

FILE NAME =	USER NAME = coxjw	DESIGNED -	REVISED -	STATE OF ILLINOIS DEPARTMENT OF TRANSPORTATION	DETAILS FOR RURAL ENTRANCE, MAILBOX TURNOUT & SIDE ROAD	F.A.P. RTE. 558	SECTION PIKE	COUNTY	TOTAL SHEETS 77	SHEET NO. 72
al\pw\work\p\wdot\coxjw\dms25409\shdtet	11a.dgn	DRAWN - JWC	REVISED -	SCALE:	SHEET NO. 2 OF 7 SHEETS	TO STA.	CONTRACT NO. 72814			
PLOT SCALE = 106.88888 / IN.		CHECKED - RSC	REVISED -	(ILLINOIS) FED. AID PROJECT						
PLOT DATE = Mar-18-2010 01:14:24PM		DATE -	REVISED -	* 118RS-2, 119RS-2, 123RS-3						