

STA. 1050+35 TO 1058+85

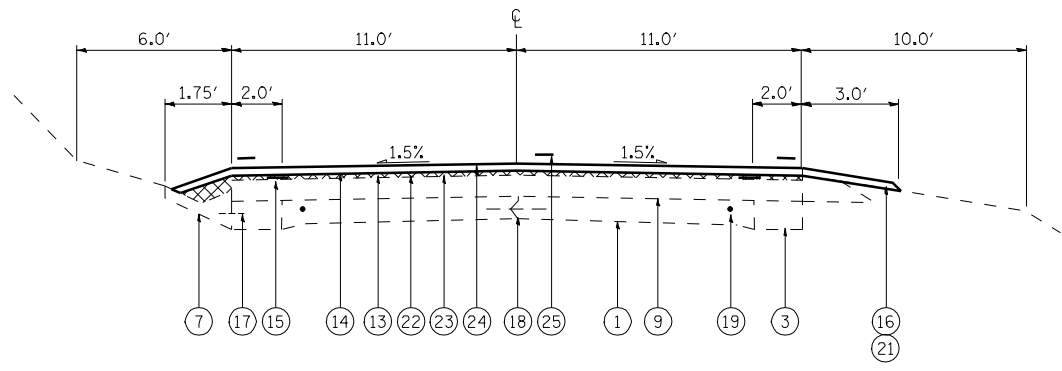

STA. 1046+30 TO 1050+35
 STA. 1058+85 TO 1059+97
 STA. 1061+86 TO 1066+59

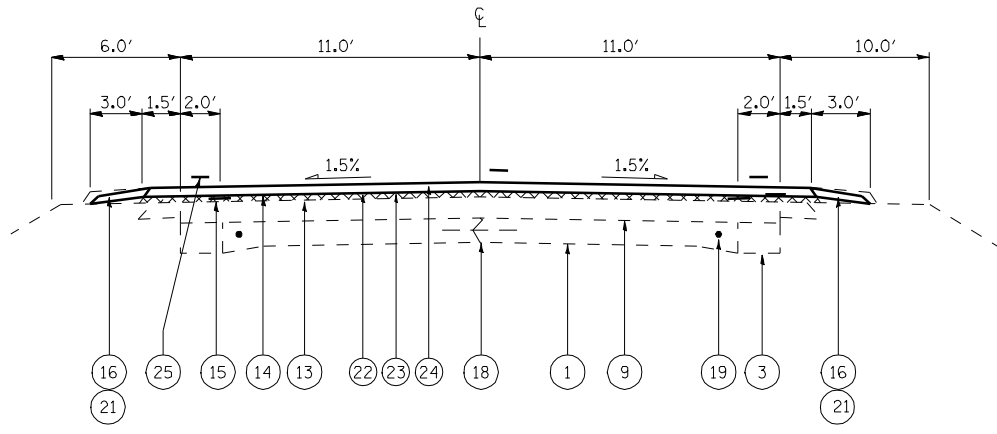

STA. 1033+29 TO 1046+30
 STA. 1059+97 TO 1061+86

LEGEND

- (1) EXISTING P.C.C. PAVEMENT, 9'-6'-9"
- (2) EXISTING P.C.C. BASE COURSE, 9"
- (3) EXISTING P.C.C. BASE COURSE WIDENING, 9"
- (4) EXISTING P.C.C. PAVEMENT, 9"
- (5) EXISTING SUB-BASE GRANULAR MATERIAL, 6"
- (6) EXISTING SUB-BASE GRANULAR MATERIAL, 12"
- (7) EXISTING CONCRETE CURB & GUTTER, TYPE B
- (8) EXISTING CONCRETE CURB & GUTTER, TYPE B-6.12
- (9) EXISTING HOT-MIX ASPHALT CONCRETE, 7.5"
- (10) EXISTING HOT-MIX ASPHALT CONCRETE, 6"
- (11) EXISTING HOT-MIX ASPHALT CONCRETE, 3"
- (12) EXISTING LEVELING BINDER (MACHINE METHOD) TYPE 2, 1"
- (13) EXISTING LEVELING BINDER (MACHINE METHOD) TYPE 2, 0.75"
- (14) EXISTING HOT-MIX ASPHALT CONCRETE SURFACE COURSE, MIX C, CLASS I, TYPE 2, 1.5"
- (15) EXISTING HOT-MIX ASPHALT CRACK CONTROL TREATMENT
- (16) EXISTING AGGREGATE SHOULDERS, TYPE A
- (17) EXISTING 0.5" DEFORMED BAR
- (18) EXISTING 0.5" DEFORMED BAR AND LONGITUDINAL METAL JOINT
- (19) EXISTING 0.75" SMOOTH BAR
- (20) EXISTING FABRIC PAVEMENT
- (21) PROPOSED AGGREGATE SHOULDERS, TYPE B
- (22) PROPOSED HOT MIX ASPHALT SURFACE REMOVAL (VARIABLE DEPTH)
- (23) PROPOSED LEVELING BINDER, 0.75"
- (24) PROPOSED HOT MIX ASPHALT SURFACE COURSE, MIX C, 1 1/2"
- (25) PROPOSED PAVEMENT MARKING, LINE - 5"

FILE NAME = e:\pwork\pwidot\LAUGHLINRL\dna25724\672b45-ah-typical.dgn	USER NAME = laughlinr1	DESIGNED -	REVISED -	STATE OF ILLINOIS DEPARTMENT OF TRANSPORTATION	TYPICAL SECTIONS		F.A.P. RTE.	SECTION	COUNTY	TOTAL SHEETS	SHEET NO.
	PLOT SCALE = 48.0000' / IN.	DRAWN - BMD	REVISED -				757	(20X)RS-5; (21X)RS-3	PIKE	34	8
PLOT DATE = Apr-07-2010 11:37:11AM	CHECKED -	DATE - 7/15/08	REVISED -	SCALE:	SHEET NO. 2 OF 6 SHEETS	STA. TO STA.	CONTRACT NO. 72B45				
				FED. ROAD DIST. NO. ILLINOIS FED. AID PROJECT							