

45 40 35 30 25 20 15 10 5 0 5 10 15 20

| | | | |
|------|----|-----------|----------|
| DATE | BY | SURVEYED | PLOTTED |
| | | NOTE BOOK | TEMPLATE |
| | | AREAS | CHECKED |
| | | AREAS | CHECKED |

| | | | |
|------|----|-----------|----------|
| DATE | BY | SURVEYED | PLOTTED |
| | | NOTE BOOK | TEMPLATE |
| | | AREAS | CHECKED |
| | | AREAS | CHECKED |

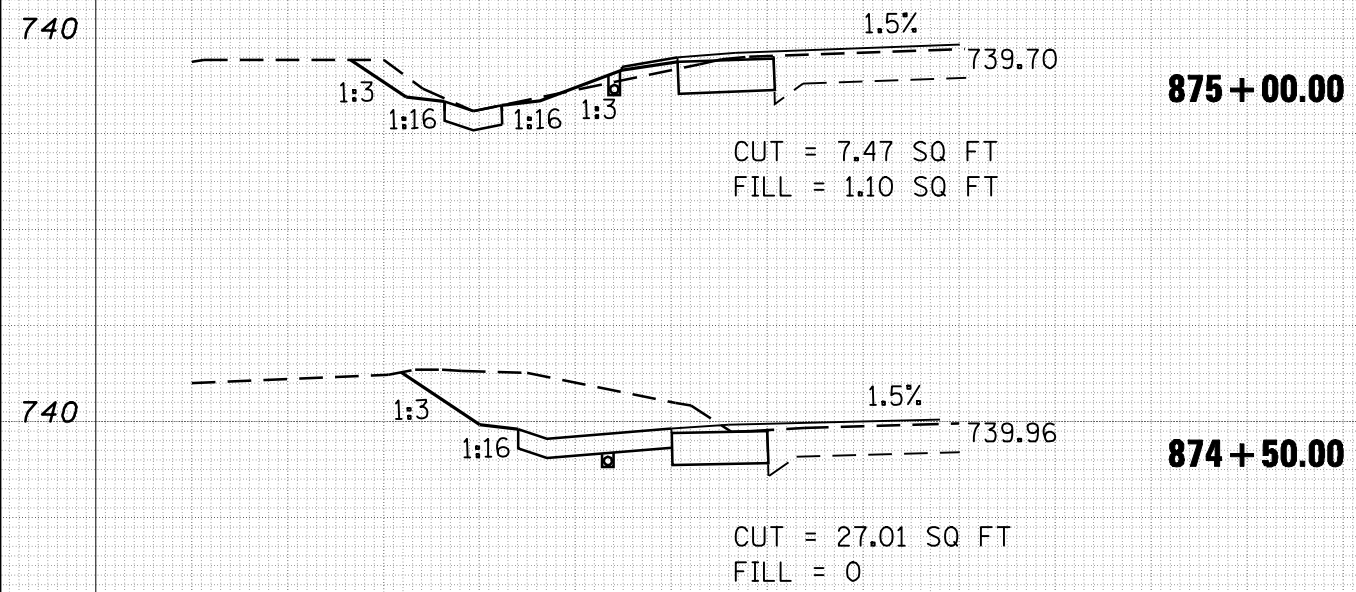

45 40 35 30 25 20 15 10 5 0 5 10 15 20

| | | | |
|--|------------------------|------------|-----------|
| FILE NAME = | USER NAME = laughlinr1 | DESIGNED - | REVISED - |
| c:\pwwork\pwidot\LAUGHLINRL\dms26879\0672B865\Shtr-xash-t2.dgn | | DRAWN - | REVISED - |
| | | CHECKED - | REVISED - |
| | | DATE - | REVISED - |

**STATE OF ILLINOIS
 DEPARTMENT OF TRANSPORTATION**

CROSS SECTIONS

SCALE: SHEET NO. 9 OF 9 SHEETS STA. 874+50.00 TO STA. 875+00.00

| F.A.P. RTE. | SECTION | COUNTY | TOTAL SHEETS | SHEET NO. |
|---------------------------|------------------|--------|--------------|-----------|
| 745 | 105RS-7, 106RS-5 | ADAMS | 47 | 40 |
| CONTRACT NO. 72B86 | | | | |
| ILLINOIS FED. AID PROJECT | | | | |