

☉ F.A.P. 321 (US 54)

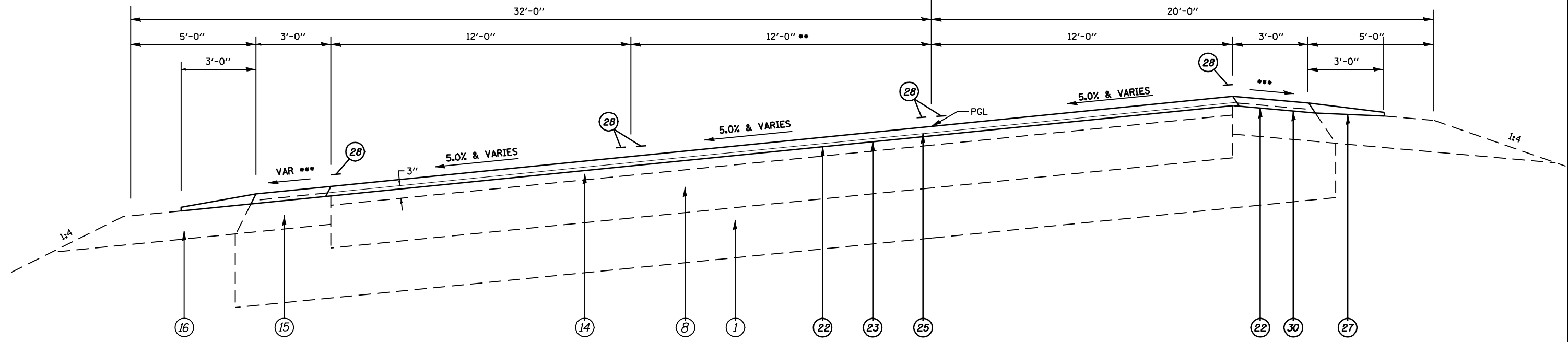

TYPICAL SECTION #9
 STA 209+62.39 TO STA 217+23.97

LEGEND

- ① EXIST. SUB-BASE GRANULAR MATERIAL, TYPE A (CA 6) 12"
- ② EXIST. LONGITUDINAL METAL JOINT W/ 1/2" DEFORMED BAR
- ③ EXIST. 3/4" SMOOTH BAR
- ④ EXIST. P.C.C. PAVEMENT 9"-7"-9"
- ⑤ EXIST. P.C.C. PAVEMENT 9"-6"-9"
- ⑥ EXIST. HOT-MIX ASPHALT CONCRETE BINDER COURSE, TYPE 2
- ⑦ EXIST. HOT-MIX ASPHALT BASE COURSE 10 3/4"
- ⑧ EXIST. HOT-MIX ASPHALT BASE COURSE 10 1/4"
- ⑨ EXIST. PCC BASE COURSE WIDENING 9"
- ⑩ EXIST. HOT-MIX ASPHALT BASE COURSE 10"
- ⑪ EXIST. CONCRETE WIDENING 8"
- ⑫ EXIST. HOT-MIX ASPHALT BASE COURSE WIDENING 9"
- ⑬ EXIST. HOT-MIX ASPHALT BASE COURSE WIDENING 10"
- ⑭ EXIST. HOT-MIX ASPHALT OVERLAY
- ⑮ EXIST. HOT-MIX ASPHALT SHOULDERS 8"

- ⑯ EXIST. AGGREGATE SHOULDERS, TYPE A
- ⑰ EXIST. AGGREGATE SHOULDERS, TYPE B
- ⑱ EXIST. COMBINATION CONCRETE CURB AND GUTTER, TYPE B-6.18
- ⑲ EXIST. COMBINATION CONCRETE CURB AND GUTTER, TYPE B-6.24
- ⑳ EXIST. CONCRETE GUTTER, TYPE A
- ㉑ PROP. HMA SURFACE REMOVAL 2"
- ㉒ PROP. HMA SURFACE REMOVAL (VARIABLE DEPTH)*
- ㉓ PROP. LEVELING BINDER (MACHINE METHOD), N70 3/4"
- ㉔ PROP. POLYMERIZED HMA SURFACE COURSE, MIX "D", N70 2"
- ㉕ PROP. POLYMERIZED HMA SURFACE COURSE, MIX "D", N70 1 1/2"
- ㉖ PROP. HOT-MIX ASPHALT SHOULDERS 8"
- ㉗ PROP. AGGREGATE SHOULDERS, TYPE B (WEDGE)
- ㉘ PROP. THERMOPLASTIC PAVEMENT MARKING - LINE 5"
- ㉙ PROP. PAINT PAVEMENT MARKING - LINE 5"
- ㉚ PROP. HOT-MIX ASPHALT SHOULDERS (2 1/4")
- ㉛ PROP. HOT-MIX ASPHALT SHOULDERS (2")

** TRANSITION FR. 12' TO 0' FR. STA. 213+88.00 TO STA. 218+68.00

*** PAVED SHOULDER SLOPE
 ON THE HIGH SIDE OF SUPERELEVATED CURVES, SLOPE THE SHOULDER SO THAT THE ALGEBRETIC DIFFERENCE BETWEEN THE PAVEMENT AND SHOULDERS ARE NOT GREATER THAN 8%
 ON THE LOW SIDE OF SUPERELEVATED CURVES, SLOPE THE SHOULDER 4% UNLESS THE SUPER ELEVATED SECTION IS GREATER THAN 4% THEN MATCH SUPERELEVATED SLOPE

*NOMINAL MILLING DEPTH 1/2"

FILE NAME =	USER NAME = coxte	DESIGNED -	REVISED -	STATE OF ILLINOIS DEPARTMENT OF TRANSPORTATION	FAP 321 (US 54) TYPICAL SECTIONS				F.A.P. RTE. 321	SECTION 106RS-5, 18RS-11	COUNTY PIKE	TOTAL SHEETS 41	SHEET NO. 9
es:\pwork\pwork\PWIDOT\COXTE\dms62291\072C43	saht:typsec.dgn	DRAWN -	REVISED -		SCALE: NTS	SHEET NO.	OF SHEETS	STA.	TO STA.	CONTRACT NO. 72C43			
	PLOT SCALE = 100.0000' / IN.	CHECKED -	REVISED -		ILLINOIS FED. AID PROJECT								
	PLOT DATE = Mar-11-2010 09:50:33AM	DATE -	REVISED -										